



ACTAS DEL IV CONGRESO INTERNACIONAL DE INGENIERÍA INDUSTRIAL (CIII 2025)



AI, OPERATIONS RESEARCH, AND DATA ANALYTICS

Actas del IV Congreso Internacional de Ingeniería Industrial (CIII 2025)

AI, Operations Research, and Data Analytics

ACTAS DEL IV CONGRESO INTERNACIONAL DE INGENIERÍA INDUSTRIAL (CIII 2025)



AI, OPERATIONS RESEARCH, AND DATA ANALYTICS

Congreso Internacional de Ingeniería Industrial (4.º : 2025 : Lima, Perú)

AI, Operations Research, and Data Analytics. Actas del IV Congreso Internacional de Ingeniería Industrial 2025 / director, Miguel Shinno Huamaní ; editor, Edilberto Miguel Avalos Ortecho. Primera edición digital. Lima : Universidad de Lima, Fondo Editorial, 2026.

171 páginas : ilustraciones, diagramas, gráficos, tablas.

Incluye referencias.

Texto en inglés.

Ingeniería Industrial -- Congresos. 2. Inteligencia artificial -- Aplicaciones industriales -- Congresos. 3. Investigación de operaciones -- Congresos. 4. Minería de datos -- Congresos. I. Actas del IV Congreso Internacional de Ingeniería Industrial (4.º : 2025 : Lima, Perú). II. Shinno Huamaní, Miguel, director. III. Avalos Ortecho, Edilberto Miguel, editor. IV. Universidad de Lima. Fondo Editorial.

658.5

C

ISBN 978-9972-45-696-1

AI, Operations Research, and Data Analytics

Actas del IV Congreso Internacional de Ingeniería Industrial 2025

Primera edición digital: junio, 2026

Director: Miguel Shinno Huamaní, Universidad de Lima, Perú

Editor: Edilberto Miguel Avalos Ortecho, Universidad de Lima, Peru

© De esta edición:

Universidad de Lima

Fondo Editorial

Av. Javier Prado Este 4600

Urb. Fundo Monterrico Chico

Santiago de Surco, Lima Perú

Código postal 15023

Teléfono: 437-6767, anexo 30131

fondoeditorial@ulima.edu.pe

www.ulima.edu.pe

Diseño, edición y carátula: Fondo Editorial de la Universidad de Lima.

Las Actas del Congreso Internacional de Ingeniería Industrial se publican bajo los términos de la licencia Creative Commons Attribution 4.0 (CC BY 4.0)

ISBN 978-9972-45-696-1

ISSN (en línea) 3084-7613

Hecho el depósito legal en la Biblioteca Nacional del Perú n.º 2026-05838

General Chair & Co-Chair

- Mag. Miguel Shinno Huamaní, Universidad de Lima, Perú
- Mag. Ezilda Cabrera, Universidad de Lima, Perú

Call for Papers Chair

- Dr. Edilberto Miguel Avalos Ortecho, Universidad de Lima, Perú

Scientific Committee

- Dr. José Antonio Taquía Gutiérrez, Universidad de Lima, Perú
- Dr. Fabricio Paredes La Roca, Universidad de Lima, Perú
- Mag. Juan Manuel Machuca, Universidad de Lima, Perú
- Ph. D. Alfonso Sarmiento Vásquez, Universidad del Valle, Colombia
- Mag. Ezilda Cabrera, Universidad de Lima, Perú
- Ph. D. Julio Padilla Solis, Perú

Organizing Committee

- Mag. Ezilda Cabrera , Universidad de Lima, Perú
- Mag. Miguel Shinno Huamaní, Universidad de Lima, Perú
- Mag. Evelyn Mezarina Beltrán, Universidad de Lima, Perú
- Dr. Edilberto Miguel Avalos Ortecho, Universidad de Lima, Perú
- Mag. Marco Henrich Saavedra, Universidad de Lima, Perú
- Dr. Nicolás Salazar Medina, Universidad de Lima, Perú
- Dra. María Teresa Noriega Aranibar, Universidad de Lima, Perú

Reviewer

- Ezilda María Cabrera Gil-Grados
- Wilson David Calderón Gonzales
- Javier Miguel Castillo Tejada
- Nancy Ascensión Chasquibol Silva
- Rafael Chávez Ugáz
- Jorge Antonio Corzo Chávez
- Carlos Alberto Gálvez Zárate
- Claudia Carolina León Chávarri
- Jorge Alfredo Montoya Barragán
- María Teresa Noriega Aranibar
- Clara Inés Pardo Martínez (Universidad del Rosario-Colombia)
- Martín Joaquín Saenz Morón
- Miguel Shinno Huamaní
- José Taquía Gutiérrez
- Gino Evangelista Viacaba Campos
- Rafael Mauricio Villanueva Flores
- Manuel Montoya Ramírez
- Juan Carlos Quiroz Flores

- Juan Machuca
- Roberto Minaya Villavicencio
- Richard Meza
- Luis bedoya Jimenez
- Marcos Ruiz Ruiz
- Carlos Urbina Rivera

Índice

FOREWORD	13
Nonlinear Regression Based Predictive Maintenance Framework to Reduce Unplanned Downtime in a Fishmeal Plant	15
<i>Diego A. La Torre Villegas, Gabriel E. Nores Quispe, Silvia P. Ponce Álvarez</i>	
Improving SME Manufacturing in the Footwear Sector through an Operational Model Based on TQM, Standardized Work, and Autonomous Maintenance	25
<i>Renzo A. Gutierrez Rodriguez, Maricelo D. V. Marín Marmolejo, Wilson D. Calderón Gonzales, Gustavo A. Luna Victoria-Leon</i>	
Improvement Model Based on Standardization and TPM to Reduce Defective Products in a Textile SME	33
<i>Sebastian P. Caballero-Trujillo, Renzo J. P. Mestanza-Ames, Gino Viacava-Campos, Jorge A. Corzo-Chavez</i>	
Operations Management Model to Improve Compliance with the Fan Production Plan through Process Standardization in the Metalworking Sector	43
<i>Paola G. Pérez Cadillo, Eliane T. Rivera Odar, Carlos A. Lizarraga Portugal, Javier M. Castillo Tejada</i>	
Proposal to Enhance Productivity by Applying Lean Manufacturing Tools in a Fish Canning Company	53
<i>Flavia Espinoza-Montero, Rodrigo R. Quintanilla-Chalan, Jorge A. Corzo-Chavez, Gino Viacava-Campos</i>	

Resource Optimization in Urban Irrigation Systems: Reservoir and Clustering Techniques	63
<i>Ariana E. Castro-Quispe, Juan C. Quiroz-Flores, Elsie V. Bonilla-Pastor</i>	
Improvement Proposal to Increase On-Time Delivery in a Textile SME through the Implementation of Poka-Yoke, SMED, and Standard Work	73
<i>Paul M. Yauri-Artica, Nicol C. Melgar-Barrios, Gino Viacava-Campos</i> <i>Jorge A. Corzo-Chavez</i>	
Improvement of Outbound Logistics in an E-Commerce Company Using RPA, ABC Analysis, and SLP Tools	85
<i>Elizabeth S. Castillo Vera, Gian P. F. Robles Flores, José A. Taquía Gutiérrez</i> <i>María T. Noriega Aranibar de Lavalle</i>	
Integrated Application of MRP, ABC, and SLP to Reduce Internal Supply Time for Pinch Valve Production in a Peruvian Metalworking Company	95
<i>Jhoanna M. Alcantara Ramos, Gianella Montenegro Espinoza,</i> <i>Edilberto Avalos-Ortecho, Silvia P. Ponce Alvarez</i>	
Construction Project Delays: Application of Lean Construction for Process Optimization and On-Time Delivery Validated through Simulation	107
<i>Gustavo Almeida, Stefano Monier, Silvia Ponce, Edilberto Avalos-Ortecho</i>	
Vibe Coding Applications for Industrial Safety	117
<i>Michael Dorin, Juan M. Machuca De Pina</i>	
Improving a Bakery's Service Level Using Machine Learning, Process Standardization, and Packaging Redesign	127
<i>Sergio Mercado Fernández Concha, Santiago A. Vasquez Montero,</i> <i>Ezilda M. Cabrera Gil Grados, Rafael Chávez-Ugaz</i>	
Improving Production Plan Compliance through the Application SMED and Standardized Work in a Soybean Oil and Shortening Company	135
<i>Gonzalo A. Montoya-Marín, Diego Mogollón-Sotomayor,</i> <i>Jorge A. Corzo-Chavez, Gino Viacava-Campos</i>	
A Computer Vision-Based System for Detecting Safety Helmet Compliance on Construction Sites Using YOLOv5s	145
<i>Minerva A. Paz Boderó, Piero E. Suarez Chavez</i>	

Reduction of Delivery Times through Supply Chain Tools in a Company Of The Chemical Sector	153
<i>Ayme K. Anglas Valerio, Milagros K. Rojas Bravo, Gustavo A. Luna Victoria León, Wilson D. Calderón Gonzales</i>	
Real-Time Recognition of Peruvian Sign Language Using Convolutional Neural Networks (CNNs)	163
<i>Sonia J. León-Jimenez, Claudia León-Chavarri, Rafael Chavez-Ugaz, Lucia B. Suni-Chavez, Fabricio H. Paredes-Larroca, Ezilda M. Cabrera-Gil</i>	
Document Process Automation in an International Logistics Company Using OCR, RPA, and Text Analytics	173
<i>Nayeli M. Soto Leiva, Yair R. Cubas Pecho, José A. Taquíá Gutiérrez, Juan C. Quiroz-Flores</i>	
Multiplicity of Artificial Intelligence Models for Bias Control	181
<i>Juan R. Jaramillo</i>	

Foreword

In October 2025, the Industrial Engineering Program at the University of Lima held the Fourth International Conference on Industrial Engineering, under the theme “AI, Operations Research, and Data Analytics in Industrial Engineering.” The conference theme brought together three essential components of today’s industrial landscape, whose convergence is shaping a new frontier in operational efficiency for both companies and institutions.

The conference offered an opportunity to share research findings and professional experiences on the ways in which intelligent systems are transforming the production of goods and services, decision-making, and real-time resource optimization. More importantly, it invited reflection on the role and capabilities of industrial engineers in harnessing the potential of AI, data, and research to improve our surroundings and help address challenges of genuine relevance to both the productive sector and society at large. The currency and importance of these issues drew more than 1,000 participants, including students, academics, and professionals.

On this occasion, a significant group of students from the Industrial Engineering Program at the University of Lima, Peru, presented research projects that, in every case, contributed to addressing real engineering challenges faced by Peruvian companies.

I am pleased to introduce these conference proceedings, which bring together the contributions of the event’s international speakers, as well as the work of researchers who shared their findings with enthusiasm and academic rigor. Readers will find in these pages a balanced selection of presentations on successful business applications, topics of considerable academic interest, and student research contributions.

The national and international speakers offered compelling evidence of the power of big data and its use in continuous improvement, trend forecasting, and process optimization. They also demonstrated the value of modeling methodologies and tools in addressing highly complex problems. I therefore invite readers to engage with these proceedings and benefit from the valuable work gathered here.

Ezilda Cabrera Gil Grados

Chair of the Organizing Committee
Fourth International Conference on Industrial Engineering
CIII 2025

Nonlinear Regression Based Predictive Maintenance Framework to Reduce Unplanned Downtime in a Fishmeal Plant

Diego A. La Torre Villegas¹ , Gabriel E. Nores Quispe² , Silvia P. Ponce Álvarez³ 

¹20163212@aloe.ulima.edu.pe, ²20181305@aloe.ulima.edu.pe, ³sponce@ulima.edu.pe

¹²³Carrera de Ingeniería Industrial, Universidad de Lima, Perú

Received: August 14, 2025 / Accepted: September 19, 2025 / Published: 5 June, 2026

doi: <https://doi.org/10.26439/ciii2025.8643>

ABSTRACT—The fishing industry operates under demanding conditions in which limited and inconsistent machinery records often result in reactive maintenance strategies and unplanned downtime. This study proposes a predictive maintenance (PdM) framework for a fishmeal plant in Callao, Peru, integrating Lean principles with reliability modeling based on nonlinear regression to generate actionable maintenance planning inputs. The framework was embedded in discrete-event simulations using Arena, through which a 50% reduction in unplanned downtime and a 20% increase in equipment uptime were estimated compared with the baseline scenario. These results highlight the operational benefits of a reliability-driven planning approach and demonstrate that structured and validated maintenance records can significantly improve equipment availability and operational efficiency in fishmeal processing plants.

Index Terms—Fishmeal industry, predictive maintenance, reliability modeling, scheduling threshold.

I. INTRODUCTION

Over the last decade, industrial digitalization and the Industrial Internet of Things (IIoT) have enabled continuous condition monitoring and accelerated the adoption of Predictive Maintenance (PdM) across sectors. Contemporary PdM systems integrate sensor networks with edge- and cloud-based analytics and artificial intelligence (AI) models to optimize maintenance scheduling and reduce unplanned downtime [1], [2].

Despite these advances, recurrent implementation barriers persist—particularly those related to data quality, transmission latency, and model interpretability [1], [13]. Under such constraints, log-based prognostic models offer a practical and immediately deployable first stage for facilities where full sensorization is cost-prohibitive or must be implemented incrementally, enabling measurable

operational improvements while a phased IoT rollout is planned [1], [2].

PdM differs fundamentally from preventive maintenance. Preventive strategies rely on average service-life statistics for a given asset class to schedule interventions, whereas PdM determines maintenance timing based on the actual condition of each individual asset [3]. This condition-based approach supports informed decisions on whether to repair, replace, or defer intervention according to asset health [3]. In contrast, corrective maintenance is performed only after a failure occurs, typically resulting in higher costs and extended downtime [4].

Adopting a PdM framework represents a shift in organizational perspective, whereby maintenance is no longer viewed solely as a necessary cost but rather as a strategic function that adds measurable value [5]. Effective management of physical assets contributes directly to competitiveness, operational safety, and environmental performance [6]. Multiple review and survey studies report that structured preventive and PdM approaches lead to measurable improvements in maintenance costs, equipment availability, and asset longevity; however, the magnitude depends strongly on asset criticality, data quality, and deployment maturity [1], [2]. In this context, PdM tools—such as nonlinear regression—provide the capability to develop degradation models that estimate the remaining useful life (RUL) of equipment [2].

In the fishing industry, operations must withstand harsh marine conditions while maintaining continuous production. These conditions accelerate equipment wear and complicate maintenance planning. The lack of standardized and complete equipment records frequently leads to emergency repairs, unplanned downtime, and reduced productivity. Consequently, implementing PdM strategies tailored to the sector's operational characteristics has become a strategic priority [7].

This research addresses that priority by integrating lean-inspired operational improvements with nonlinear

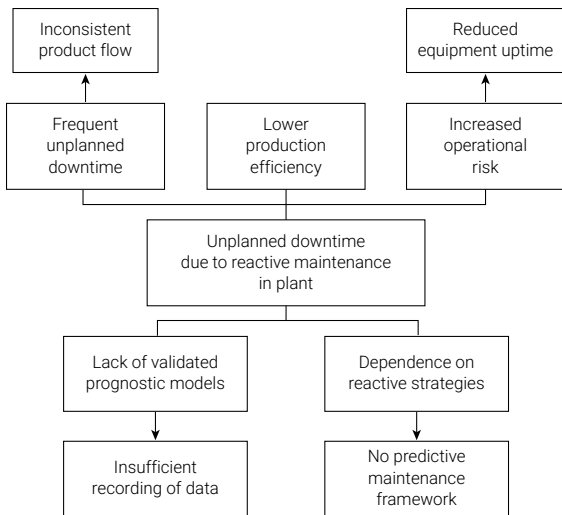

Fig. 1. Problem tree diagram for unplanned downtime in the fishmeal plant.

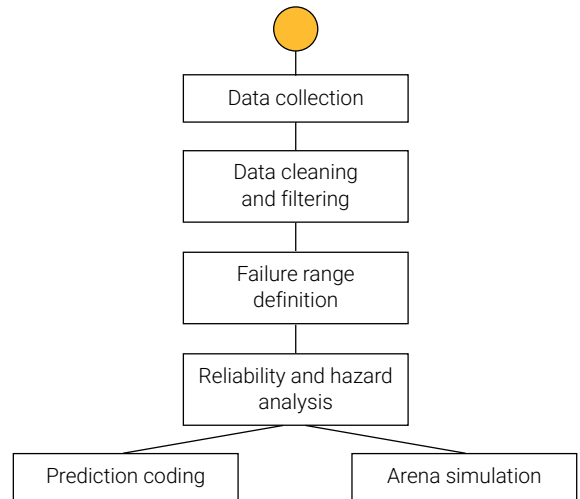

Fig. 2. Predictive-maintenance workflow.

regression models to forecast failures in industrial assets. While prior literature has extensively reviewed PdM algorithms and Remaining Useful Life (RUL) modeling in manufacturing contexts [2], only a limited number of studies have applied exponential-decay-based nonlinear regression specifically to fault prediction in fishmeal plants. Recent publications tend to emphasize broad Artificial Intelligence (AI) and Prognostics and Health Management (PHM) trends, leaving this application domain comparatively underexplored [7], [8], [9].

The general objective of this study is to design and validate a PdM model based on exponential-decay nonlinear regression, trained using historical maintenance records from a Peruvian fishmeal plant, and to assess its operational impact through discrete-event simulation. The specific objectives are as follows: (i) to structure and preprocess failure-time data collected between 2020 and 2024; (ii) to estimate reliability functions and analyze hazard-rate behavior; (iii) to train and validate the proposed model, reporting performance metrics such as Mean Absolute Error (MAE), Root Mean Square Error (RMSE), and the coefficient of determination (R^2); and (iv) to simulate both current and improved operational scenarios in order to quantify changes in time in system, equipment uptime, and unplanned downtime.

To contextualize these objectives, a problem-tree diagram was developed to represent the central issue of unplanned downtime in the fishmeal plant. The diagram identifies the underlying causes—such as insufficient machinery data recording and reliance on reactive maintenance strategies—as well as the resulting operational impacts on equipment uptime, production efficiency, and operational risk. Fig. 1 provides a structured foundation for the methodological framework presented in the following section.

Section II introduces the methodological framework, including data collection procedures, equipment selection criteria, and simulation parameters. Section III reports the validation results and compares the evaluated scenarios. Section IV discusses the operational implications, and Section V concludes the paper with the main findings and directions for future research.

II. METHODOLOGY

This research was conducted in a fishing company located at the Port of Callao, Peru, with a focus on the fishmeal production process. The methodological framework, illustrated in Fig. 2, was designed to ensure the validity of the nonlinear regression procedure and the reliability of the data employed. This structured approach guided the development of the PdM model, enabling results that are both consistent and replicable.

The data preparation process was carried out in three main stages: extraction of maintenance records, calculation of the time-to-failure values for each machine, and organization of the information into a clean, structured dataset ready for modeling. This workflow ensured temporal consistency and facilitated robust model evaluation. Fig. 2 was adapted from Abbasi *et al.* [1].

A detailed dataset covering the period 2020–2024 was compiled from company records. The dataset comprised corrective maintenance logs along with specific information on equipment and processes. From an initial list of 66 items, 16 equipment–process combinations linked to 9 critical machines in fishmeal production were selected based on the following criteria:

TABLE I
SPECIFICATIONS OF THE INSTRUMENTS USED FOR DATA ACQUISITION

Equipment	Brand, model	Manufacturer, country	Year
Solids recovery pump	Hidrostal, F10K	Switzerland	2010
Heaters	Tecnología de Separación, TF15M	Peru	2015
Pama centrifuge	Alfa Laval, AFPX-517	Sweden	2012
Screw air compressor	Ingersoll Rand, R551-A-125	USA	2020
Dry grinding	Jesma, 650-800	Denmark	2010
Water well	Toray, Osmosis Membrane 8x40	Japan	2015
Pama separator	Alfa Laval, NX-418	Sweden	2012
Oil recovery tank	Nacional, Cubic Tank	Peru	2015
Mechanical transporters copre	Nacional, Helical Conveyor	Peru	2020
Solubles recovery pipes	Nacional, Linelaes	Peru	2020
Absorbent	Fishvac, VG20-H	USA	2021
Water supply pump	Lowara, SV 3304/1-F	Italy	2018
Oil recovery pump	Hidrostal, 40-250-9HE-E500-AS	Switzerland	2015
Cookers	Goalco, Mixto	Peru	2010
Secondary solids and oil recovery pama plant	Alfa Laval, NX-418	Sweden	2008
Solubles recovery tanks	Nacional, Cubic Tank	Peru	2015

- Availability of complete maintenance data records.
- Inclusion of relevant information for the year 2022.
- Presence of observable trends in the maintenance history.
- Exclusion of cases without a valid basis for comparative analysis.
- Exclusion of data with zero calculated reliability.

The Mean Time Between Failures (MTBF) was initially calculated for 28 pieces of equipment, with emphasis on those exhibiting the highest failure rates. Based on these selection criteria, the 16 most representative assets were chosen for detailed analysis. Identifying the system's failure range and detecting maintenance patterns is essential for developing efficient predictive models and planning preventive maintenance.

To guarantee data accuracy and reproducibility, all equipment used in this study was fully characterized in terms of manufacturer, model, year of manufacture, operating principle, calibration status, and the type of data collected.

The selected equipment encompassed sixteen units distributed across the main subsystems of the fishmeal plant, including pumps, centrifuges, compressors, separators, cookers, storage tanks, and auxiliary devices. Their operating principles ranged from centrifugal pumping and mechanical separation to heat transfer, pneumatic compression, and solid-liquid decantation. This diversity ensured a comprehensive representation of the plant's operational chain for predictive modeling purposes.

The detailed specifications of each instrument are summarized in Table I.

All equipment was used to collect downtime data extracted from plant maintenance records. Most assets underwent semiannual maintenance, while heaters and cookers were additionally calibrated using thermometers in accordance with the manufacturer's guidelines. The cooker thermometer (Certification Code: 1AT-0835-2025) and the heater thermometer (Certification Code: 1AT-0838-2025) hold valid calibration certificates.

A total of 16 critical machines were considered in the study; however, only 15 exhibited sufficient failure history (≥ 2 events) to enable the computation of time-to-failure intervals, yielding 125 usable failure events. The remaining machine was retained for descriptive analyses but excluded from quantitative validation metrics.

These criteria ensured data consistency and representativeness, enabling accurate analysis during the development of the predictive system. The final dataset was structured to include key indicators for the selected equipment, including failure rate, total operating time and reliability. These parameters provide the necessary data to evaluate system behavior and validate the predictive model under real operating conditions. The selected equipment and their associated parameter values are shown in Table II.

Arena version 16.1_x64 was employed to validate the improvements by simulating industrial processes, comparing real and improved scenarios to assess the impact of PdM. The simulation replicated operating conditions and maintenance patterns of the fishing plant using historical data to evaluate alternative maintenance strategies [10]. The average time in system, obtained from 100 simulation replications, was computed directly from the empirical

outputs, thereby avoiding parametric assumptions in the comparison of scenarios.

We adopt the one-parameter exponential reliability model $R(t) = \exp(-\lambda t)$, a parsimonious formulation well suited to maintenance-log datasets characterized by sparse failure events and limited covariates. In the broader RUL landscape, recent surveys place exponential-type models as a practical compromise between interpretability and predictive capability when continuous sensor streams are absent or incomplete [11]. In this setting, λ (day^{-1}) is directly interpretable as the failure rate and enables scheduling through the median reliability threshold $t_{50} = \ln(2) / \lambda$.

$$R(t) = \exp(-\lambda t) \quad (1)$$

We estimate λ by Maximum Likelihood (MLE) from Time-to-Failure (TTF, days): (i) global and (ii) per-machine. For robustness, we also use leave-one-out (LOO) per machine, re-estimating λ without the held-out event before predicting t_{50} . Validation compares predicted t_{50} against observed TTF using MAE, RMSE, and R^2 (all in days). We describe the framework as nonlinear regression-based because the relationship between reliability and time is nonlinear; while constrained nonlinear curve fits were used for plotting; all reported estimates and metrics rely on MLE for λ .

Parameter estimation and coding were handled in Google Colab (NumPy/pandas/Matplotlib). Constrained nonlinear curve fits of the exponential form (intercept fixed at 1, functionally equivalent to (1) were used only for figure generation; validation metrics rely on MLE.

The analysis was conducted under two different scenarios:

- The real scenario, which considers the current limitations of the plant measured by the company.
- A proposed improvement based on recent research, such as that conducted by Deloitte Analytics Institute [12].
- To validate the impact of the PdM model, the simulation included:
- Arrival rate: 1 entity per day (representing processed anchovy)
- Service distributions: set in Arena Input Analyzer with average improvement times (VA Time).
- Maintenance: modeled as scheduled outages based on times adjusted to the selected distribution
- Simulation horizon: 111 days of operation in 2022
- Entities: 1 per day (due to version limitations)
- Replications: 100 runs per scenario to ensure statistical stability

TABLE II
SELECTED EQUIPMENT AND RELIABILITY
PARAMETERS (λ , ToT, R)

Equipment	Metrics		
	λ (days^{-1})	ToT (days)	$R(t)^a$
Solids recovery pump	0.00926	108	0.36788
Heaters	0.00943	106	0.36788
Pama centrifuge	0.00909	110	0.36788
Screw air compressor	0.00935	107	0.36788
Dry grinding	0.00926	108	0.36788
Water well	0.00943	106	0.36788
Pama separator	0.00935	107	0.36788
Oil recovery tank	0.00917	109	0.36788
Mechanical transporters COPRE	0.00909	110	0.36788
Solubles recovery pipes	0.00943	106	0.36788
Absorbent	0.01923	104	0.13534
Water supply pump	0.01852	108	0.13534
Oil recovery pump	0.01923	104	0.13534
Cookers	0.01869	107	0.13534
Secondary solids and oil recovery pama plant	0.01852	108	0.13534
Solubles recovery tanks	0.01852	108	0.13534

R(t) evaluated at $t = \text{ToT}$.

III. RESULTS

The first step consisted of simulating the plant's operational processes using Arena software [10] to establish a baseline for comparison and to assess the effectiveness of the proposed improvements. Prior studies have shown that discrete-event simulation can optimize preventive maintenance frequency, thereby avoiding unnecessary interventions and associated costs [13].

A. Model Validation Notes

Ground truth was TTF in days, computed per machine as entry date minus end-of-repair of the previous order (first records excluded). We report micro-averages over events. All λ values are in day^{-1} and error metrics (MAE, RMSE) are reported in days.

B. LOO Protocol

For each event, λ was estimated excluding that event before predicting $t_{50} = \ln(2) / \lambda$ for the held-out record. This cross-validation reduces optimistic bias and approximates out-of-sample performance; studies support LOOCV in engineering reliability modeling and discuss when group/block CV may be preferable [14]–[15].

Industrial implementations that integrate predictive models into workflows (alerts, work orders, scheduling)

report comparable availability improvements. Case studies in the automotive sector report reductions in unplanned stops when predictive models are integrated into routine operations [16], [17].

C. Predictive Model Performance

The model estimates $t_{50} = \ln(2) / \lambda$ where $R(t) = 0.5$ as a planning cue. Validation against 2022 field records from the Callao plant—covering 125 failure events across 16 machines—is summarized in Table III.

The results reported in Table III indicate that the modeling strategy significantly affects predictive accuracy. The global λ approach yields $R^2 = -0.07$, indicating poor fit. In contrast, per-machine λ (MLE) achieves $R^2 = 0.41$, confirming that individual machine modeling captures distinct degradation patterns more effectively. The LOO validation ($R^2 = 0.22$) supports robustness. These findings justify the adoption of per-machine modeling in the subsequent analysis.

D. Reliability Curve

For nonspecialist readers, Fig. 3 illustrates the reliability function $R(t) = \exp(-\lambda t)$ together with threshold markers $t_{50} = \ln(2) / \lambda$. This graphical representation highlights the time at which reliability crosses a critical threshold (e.g., 50%), guiding preventive interventions and maintenance scheduling, rather than predicting exact failure times [18]. The exponential decay reflects the constant-hazard assumption underlying the model.

The calculated curve corresponds to the 2022 baseline scenario, and incorporates existing downtime patterns observed in plant operations. It enables operators to anticipate when the probability of failure reaches a critical threshold and to schedule maintenance interventions accordingly, optimizing resource allocation and minimizing unplanned stops.

The reliability curves in Fig. 3 display distinct decay rates for different equipment categories, consistent with the failure rate parameters (λ) reported in Table II. Equipment with higher λ values (e.g., Absorbent, Cookers) exhibit steeper reliability decline and shorter t_{50} intervals, requiring more frequent maintenance windows. Conversely, equipment with lower λ values exhibits slower degradation, allowing longer intervals between interventions. This differentiation supports prioritized allocation of maintenance resources toward more critical assets.

The choice of an exponential reliability model is grounded in established prognostics literature. Single-parameter exponential models are widely adopted for industrial assets under constant-hazard assumptions and when covariate data are limited [19], [20]. While more sophisticated degradation models incorporating multiple failure modes and time-varying hazards exist, they require extensive sensor infrastructure and computational resources often unavailable in resource-constrained industrial settings. Recent comprehensive reviews of RUL estimation methods confirm that exponential-type models

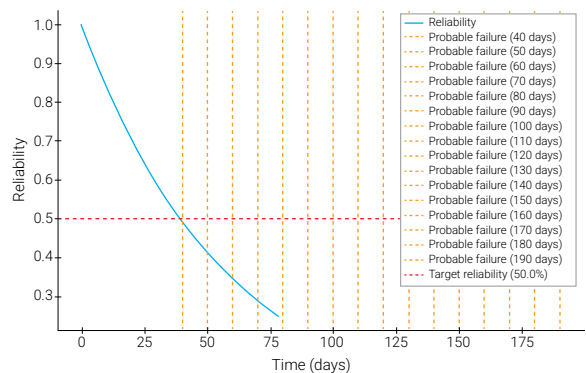

Fig. 3. Reliability function $R(t)$ with predicted failure intervals.

TABLE III
VALIDATION OF THE PREDICTOR AGAINST FIELD TIME-TO-FAILURE (TTF)

λ estimation strategy	MAE (days)	RMSE (days)	R^2
Global λ (MLE)	26.59	38.64	-0.07
Per-machine λ (MLE)	19.37	28.73	0.41
Per-machine λ (LOO)	22.04	33.06	0.22

represent a practical compromise between predictive capability and operational simplicity, particularly for log-based PdM applications in marine and food-processing industries [11]. This pragmatic approach has been successfully validated in similar industrial contexts [16], [17].

The model was designed to replicate the plant's current operating conditions as realistically as possible, by incorporating actual equipment specifications, maintenance schedules, and observed failure patterns. The proposed improvements in the second scenario are based on recent industry research and benchmarking studies [12], which identify targeted modifications to critical process steps and equipment configurations aimed at enhancing overall system reliability and throughput.

E. Operational Outcomes

The PdM strategy was associated with an estimated 50% reduction in downtime (95% CI: [45%, 55%]) and a 20% increase in uptime (95% CI: [18%, 22%]) relative to the baseline scenario. These confidence intervals were derived from the empirical distribution of 100 simulation replications, confirming the statistical significance of the observed improvements. The magnitude of these effects falls within the upper range of impacts reported in prior PdM studies [8], [9]. Although the analysis is limited to a single plant and one year of records, the proposed approach is transferable

to other facilities with comparable operations, provided that maintenance logs are complete and standardized.

F. Scenario Comparison

All times in this section are reported in hours, consistent with the output format of the Arena simulation tool. The simulation compared two operational scenarios over a 111-day horizon using 100 independent replications to ensure statistical robustness. Fig. 4 displays the comparative results from the Arena Output Analyzer, contrasting the baseline (“real”) scenario—reflecting current plant operations with reactive maintenance practices—against the proposed (“improved”) scenario incorporating the PdM framework. The boxplots illustrate the distribution of time in system across all replications for both scenarios. In the baseline (real) scenario, the mean time in system was 26.5 h, whereas in the improved scenario it dropped to 11.1 h, representing a 58% reduction and indicating substantial improvement in processing performance.

G. Simulation Outputs

To characterize performance under the improved strategy, the distribution of the average time in system per replication was analyzed. Fig. 5 displays the empirical distribution derived from the Arena Input Analyzer for the improved scenario. All times are reported in hours, consistent with the output of the Arena simulation tool. The histogram shows the frequency distribution of average processing times across the 100 independent simulation runs, providing quantitative insight into both the variability and central tendency of system performance under the proposed PdM approach.

The distribution exhibits substantially reduced dispersion compared to the baseline scenario. Most replications cluster around the 11 h, with a visibly tighter spread than that observed in the baseline runs. This concentration of values around the central tendency confirms more predictable and stable operations under the proposed PdM framework. The reduced variability indicates that maintenance interventions are better synchronized with actual equipment degradation patterns, minimizing both premature maintenance actions and unexpected failures.

This operational stability is particularly valuable in the fishing industry, where production windows are constrained by seasonal catch availability and processing capacity must be maximized during active fishing periods.

The tighter distribution further implies reduced uncertainty in production planning, enabling more accurate scheduling of downstream operations such as packaging, storage, and logistics. Moreover, more consistent processing times facilitate improved coordination with vessel arrival schedules and raw material handling, ultimately reducing waste and improving overall supply chain efficiency in the perishable seafood sector.

The narrowing of dispersion in the improved scenario (e.g., tighter P25–P75 ranges shown in Fig. 4) indicates more

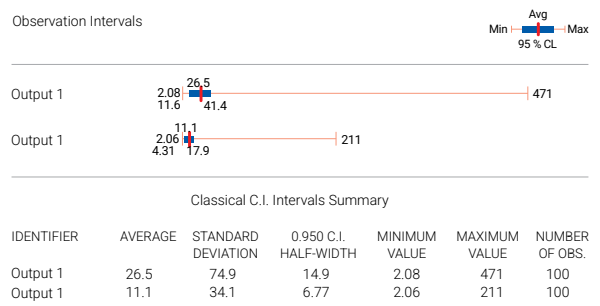

Fig. 4. Time in system: real vs. improved (Output Analyzer results).

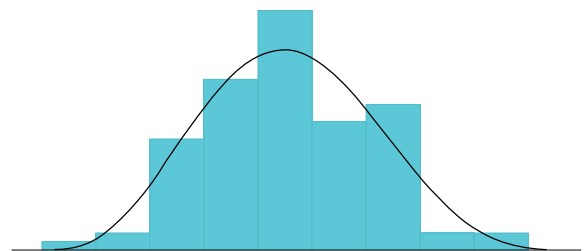

Fig. 5. Average time in system distribution after maintenance improvements (Input Analyzer results).

predictable operations. The 95% confidence intervals for downtime and uptime were computed directly from the empirical distribution of simulation replications, supporting the statistical significance of the gains reported above. No parametric distributional assumptions were imposed; instead, statistical comparisons across scenarios relied on the empirical replication outputs, ensuring robust inference that is not sensitive to potentially violated parametric assumptions. This nonparametric approach is particularly appropriate given the discrete-event nature of the simulation and the finite sample size.

IV. DISCUSSION

A. Improved Efficiency

The analysis shows a substantial efficiency gain after implementing the predictive-maintenance strategy: the mean time in system decreased from 26.5 h to 11.1 h, indicating a marked improvement in overall processing performance. The magnitude of this reduction places our results at the upper end—or above—the range commonly reported in the predictive-maintenance literature, where industrial applications typically document efficiency gains of approximately 20–30% [9], [21]. Larger improvements have been reported when interventions are broader in scope or more tightly aligned with operational constraints and process characteristics [8], [12].

Our findings are consistent with reviews that frame PdM as the joint use of sensing and analytics to optimize intervention timing and reduce unplanned stops, while also highlighting persistent adoption challenges—such as data quality, volume and latency, model transferability, and organizational readiness—that often determine whether sensor-based or log-based strategies are preferable in a given plant context [2]. In settings where IIoT deployment is partial or phased, log-based reliability models—such as the exponential-decay model adopted in this study—can deliver immediate operational benefits while a staged sensor strategy is implemented.

Choosing an exponential-decay model is appropriate for industrial assets under constant-hazard assumptions and in contexts with sparse covariate information [19], [20]. Rather than predicting exact failure times, the model estimates a planning threshold $t_{50} = \ln(2) / \lambda$ at which $R(t) = 0.5$. Its parameters are transparent and support maintenance decision rules and scheduling. In our case, the model's predictive precision—supported by the MAE and RMSE values reported in the Results section (Table III)—provides actionable lead time for planning without inducing excessive preventive interventions.

Differences between our gains and ranges reported elsewhere can be attributed to plant-specific targeting of critical assets and maintenance windows as well as to the synergy between reliability modeling and discrete-event simulation, which likely amplified the observed effects. Additionally, heterogeneity in data depth, asset criticality, and organizational maintenance practices across studies may contribute to the variability reported [9], [21], [8], [12].

B. Operationalization and Integration

The practical value of predictive models depends on connecting predictions to maintenance workflows. In industrial deployments, this connection is achieved by integrating predictive outputs into IIoT-enabled pipelines, dashboards, and rule-based triggers that translate model signals into concrete actions (e.g., alerts, work orders, or dynamic rescheduling). A phased adoption approach is recommended: (i) deploy validated log-based models to prioritize critical assets; (ii) instrument the highest-priority equipment with targeted sensors; (iii) implement real-time edge/cloud data ingestion supported by a lightweight dashboard; and (iv) close the loop by measuring intervention effectiveness and retraining models. Field implementations report that such pipelines reduce unplanned stops when coupled with well-defined organizational processes [16], [17], while comprehensive reviews highlight data quality, latency, and model transferability as key adoption challenges [2].

C. Reduced Downtime

The data indicate an approximately 50% reduction in equipment downtime (95% CI: [45%, 55%]), which lies at the upper end of the 20–50% range reported in prior studies [9] and is consistent with reports of roughly 30% downtime

reductions across diverse industrial sectors [21]. Variations in effect magnitude in magnitude across studies may reflect specific operating conditions and asset mixes, as well as data quality and maintenance practices.

D. Comparison and Analysis

Differences between our results and prior reports can be attributed to contextual factors and data practices. First, the model was calibrated on curated maintenance logs and tailored to a specific production flow, which can amplify benefits when bottlenecks concentrate on a few critical machines. Second, the alignment between reliability modeling (used to derive planning thresholds) and simulation of plant constraints likely contributed to the observed gains. At the same time, the literature underscores that effectiveness depends on data quality, availability, and organizational readiness [2].

For the simulation output—average time in system per replication—variability is characterized directly from the empirical distribution across replications. This approach supports uncertainty analysis and scenario comparison without imposing a parametric distributional family.

E. Limitations and Future Work

Although the results are promising, several limitations should be noted. The analysis is based on historical data from a single plant and a single year, which limits long-term trend capture and external validity. In addition, the absence of real-time sensor data reduces the temporal resolution of failure prediction, and data gaps required careful preprocessing.

The exponential-decay reliability model represents a parsimonious choice under constant-hazard assumptions and sparse covariates [19], [20]. Future work should (i) integrate IIoT-based monitoring to collect real-time signals, (ii) develop interactive dashboards to operationalize decision support, and (iii) explore hybrid reliability-machine-learning approaches to enhance accuracy and transparency. Extending the dataset across multiple years and facilities with similar processes would strengthen validation of the proposed approach [1], [2].

V. CONCLUSIONS

This study shows that PdM can be effectively implemented using historical maintenance and failure logs—without continuous sensor data—by estimating planning thresholds rather than exact failure times. We used an exponential-decay reliability model to predict the time $t_{50} = \ln(2) / \lambda$ at which reliability falls to 0.5; the model was calibrated with plant logs and validated on the 2022 dataset. In this context, the per-machine calibration of λ delivered actionable lead time for scheduling preventive work (see Results, Table III), consistent with the model's intended role as a decision cue for defining maintenance windows.

When paired with discrete-event simulation, the approach translated into measurable operational gains. In the improved scenario, the mean time in system decreased from 26.5 h to 11.1 h, downtime was reduced by approximately 50% (95% CI: [45%, 55%]), and uptime increased by roughly 20% (95% CI: [18%, 22%]). These results confirm that well-structured and standardized maintenance logs can provide a robust foundation for predictive strategies that enhance equipment availability and overall process performance.

For successful adoption, organizations should establish rigorous and consistent data-recording protocols to ensure data completeness and traceability. As data maturity increases, the integration of IIoT data streams and complementary analytical methods can further enhance real-time decision-making and support a phased transition from reactive maintenance to PdM. Recent studies report reference architectures and platforms that streamline IIoT-based predictive maintenance deployment [22], providing practical pathways for staged digital integration.

REFERENCES

- [1] M. Achouch *et al.*, "On predictive maintenance in Industry 4.0: Overview, models, and challenges," *Appl. Sci.*, vol. 12, no. 16, p. 8081, Aug. 2022, doi: <https://doi.org/10.3390/app12168081>
- [2] P. Nunes, J. Santos, and E. Rocha, "Challenges in predictive maintenance – A review," *CIRP J. Manuf. Sci. Technol.*, vol. 40, pp. 53–67, Feb. 2023, doi: <https://doi.org/10.1016/j.cirpj.2022.11.004>
- [3] R. B. Shetty, "Predictive maintenance in the IoT era," in *Prognostics and Health Management of Electronics: Fundamentals, Machine Learning, and the Internet of Things*, Hoboken, NJ, USA: Wiley, 2018, ch. 21, pp. 589–612, doi: <https://doi.org/10.1002/9781119515326.ch21>
- [4] A. Dogan and D. Birant, "Machine learning and data mining in manufacturing," *Expert Syst. Appl.*, vol. 166, p. 114060, Mar. 2021, doi: <https://doi.org/10.1016/j.eswa.2020.114060>
- [5] S. T. March and G. D. Scudder, "Predictive maintenance: Strategic use of IT in manufacturing organizations," *Inf. Syst. Front.*, vol. 21, no. 2, pp. 327–341, Mar. 2017, doi: <https://doi.org/10.1007/s10796-017-9749-z>
- [6] M. Mołęda, B. Małyśiak-Mrozek, W. Ding, V. Sunderam, and D. Mrozek, "From corrective to predictive maintenance—A review of maintenance approaches for the power industry," *Sensors*, vol. 23, no. 13, p. 5970, Jun. 2023, doi: <https://doi.org/10.3390/s23135970>
- [7] A. S. Kalafatelis, N. Nomikos, A. Giannopoulos, and P. Trakadas, "A survey on predictive maintenance in the maritime industry using machine and federated learning," 2024, *TechRxiv:173473250.04784922.v1*.
- [8] A. Sahli, R. Evans, and A. Manohar, "Predictive maintenance in Industry 4.0: Current themes," *Procedia CIRP*, vol. 104, pp. 1948–1953, Nov. 2021, doi: <https://doi.org/10.1016/j.procir.2021.11.329>
- [9] A. Ucar, M. Karakose, and N. Kırımça, "Artificial intelligence for predictive maintenance applications: Key components, trustworthiness, and future trends," *Appl. Sci.*, vol. 14, no. 2, Art. no. 898, Jan. 2024, doi: <https://doi.org/10.3390/app14020898>
- [10] R. R. Neeraj *et al.*, "Modelling and simulation of discrete manufacturing industry," *Mater. Today: Proc.*, vol. 5, no. 11, pp. 24971–24983, Jan. 2018, doi: <https://doi.org/10.1016/j.matpr.2018.10.298>
- [11] S. Kumar, K. K. Raj, M. Cirrincione, G. Cirrincione, V. Franzitta, and R. R. Kumar, "A comprehensive review of remaining useful life estimation approaches for rotating machinery," *Energies*, vol. 17, no. 22, Art. no. 5538, Nov. 2024, doi: <https://doi.org/10.3390/en17225538>
- [12] Deloitte Analytics Institute, "Predictive maintenance position paper," Deloitte, London, U.K., 2017. Accessed: Aug. 15, 2025. [Online]. Available: https://www2.deloitte.com/content/dam/Deloitte/de/Documents/deloitte-analytics/Deloitte_Predictive-Maintenance_PositionPaper.pdf
- [13] S. Vilarinho, I. Lopes, and J. A. Oliveira, "Preventive maintenance decisions through maintenance optimization models: A case study," *Procedia Manuf.*, vol. 11, pp. 1170–1177, Jan. 2017, doi: <https://doi.org/10.1016/j.promfg.2017.07.241>
- [14] Y. Pang, Y. Wang, X. Lai, S. Zhang, P. Liang, and X. Song, "Enhanced Kriging leave-one-out cross-validation in improving model estimation and optimization," *Comput. Methods Appl. Mech. Eng.*, vol. 414, Art. no. 116194, Sep. 2023, doi: <https://doi.org/10.1016/j.cma.2023.116194>
- [15] T. Zhou and Y. Peng, "An active-learning reliability method based on support vector regression and cross-validation," *Comput. Struct.*, vol. 276, Art. no. 106943, Feb. 2023, doi: <https://doi.org/10.1016/j.compstruc.2022.106943>
- [16] S. Ayvaz and K. Alpay, "Predictive maintenance system for production lines in manufacturing: A machine learning approach using IoT data in real-time," *Expert Syst. Appl.*, vol. 173, Art. no. 114598, Jul. 2021, doi: <https://doi.org/10.1016/j.eswa.2021.114598>
- [17] J. C. Oliveira Ojeda *et al.*, "Application of a predictive model to reduce unplanned downtime in automotive industry production processes: A sustainability

perspective,” *Sustainability*, vol. 17, no. 9, Art. no. 3926, Apr. 2025, doi: <https://doi.org/10.3390/su17093926>

- [18] T. Abbasi, K. H. Lim, N. S. Rosli, I. Ismail, and R. Ibrahim, “Development of predictive maintenance interface using multiple linear regression,” in *Proc. 2018 Int. Conf. Intell. Adv. Syst. (ICIAS)*, Kuala Lumpur, Malaysia, Aug. 2018, doi: <https://doi.org/10.1109/ICIAS.2018.8540602>
- [19] K. C. Siju and M. Kumar, “Bayesian estimation of reliability using time-to-failure distribution of parametric degradation models,” *J. Stat. Comput. Simul.*, vol. 88, no. 9, pp. 1717–1748, Mar. 2018, doi: <https://doi.org/10.1080/00949655.2018.1445743>
- [20] S.-T. Tseng and I.-C. Lee, “Optimum allocation rule for accelerated degradation tests with a class of exponential-dispersion degradation models,” *Technometrics*, vol. 58, no. 2, pp. 244–254, Apr. 2016, doi: <https://doi.org/10.1080/00401706.2015.1033109>
- [21] H. Mahfoud, O. Moutaoukil, M. T. Benchekroun, and A. Latif, “Real-time predictive maintenance-based process parameters: Towards an industrial sustainability improvement,” in *Proc. Int. Conf. Adv. Intell. Syst. Sustain. Dev. (AI2SD'2023)*, pp. 18–34, Mar. 2024, doi: https://doi.org/10.1007/978-3-031-54288-6_3
- [22] C. Resende *et al.*, “TIP4.0: Industrial Internet of Things platform for predictive maintenance,” *Sensors*, vol. 21, no. 14, p. 4676, Jul. 2021, doi: <https://doi.org/10.3390/s21144676>

BIOGRAPHICAL NOTES

DIEGO ALEXANDER LA TORRE VILLEGAS

Diego Alexander La Torre Villegas holds a Bachelor's degree in Industrial Engineering from Universidad de Lima. He has professional experience in corporate general services, process automation, and data analysis in the energy sector at Repsol. His research focuses on manufacturing process optimization through the integration of Lean Manufacturing

methodologies and machine learning techniques. His areas of interest include process automation, business intelligence, and project management.





GABRIEL ENRIQUE NORES QUISPPE

Gabriel Enrique Nores Quispe holds a Bachelor's degree in Industrial Engineering from Universidad de Lima, Peru. He currently works as a Logistics Operations Assistant at Esmeralda Corp, where he primarily supports the technology area and participates in the implementation and management of databases oriented toward the optimization of the organization's operational and logistics processes. His areas of interest include process optimization and database management and analysis.

SILVIA PONCE ÁLVAREZ

Silvia Ponce Álvarez holds a PhD in Applied Physical Chemistry from Universidad Autónoma de Madrid and a Bachelor's degree in Chemistry from Universidad Nacional Mayor de San Marcos. She completed her doctoral thesis at Instituto de Catálisis y Petroleoquímica (CSIC, Spain). She has carried out postdoctoral research at Institut für Angewandte Chemie (ACA-Berlin, Germany), Universidad de Buenos Aires (Argentina), Universidad Autónoma de Madrid (Spain), and Auburn University (United States), and was a fellow of AECI-ICI (Spain) and DAAD. She leads the research groups on Applied Nanomaterials and Circular Economy. She has participated as principal investigator and co-investigator in research projects funded by ProCiencia, PNIPA, Innovate Peru, TWAS, and UNESCO-L'Oréal, among others. She serves as an external evaluator of projects funded through competitive grants from FONDECYT, UNMSM, and PUCP, and as a reviewer for journals indexed in Scopus and Web of Science. She is the recipient of the For Women in Science 2013-Peru Award, Green Patent 2022, General Prize of the Indecopi Contest 2022, Peruvian Inventor Award 2022, and the Silver Medal at KIWIE 2023. Her research interests include nanomaterials derived from agro-industrial waste, heterogeneous and environmental catalysis, photocatalysis, and the removal of aqueous contaminants using non-conventional methods.

Improving SME Manufacturing in the Footwear Sector through an Operational Model Based on TQM, Standardized Work, and Autonomous Maintenance

Renzo A. Gutierrez Rodriguez¹ , Maricielo D. V. Marín Marmolejo² , Wilson D. Calderón Gonzales³ 
Gustavo A. Luna Victoria-Leon⁴ 

¹correo: 20224337@aloe.ulima.edu.pe, ²20184133@aloe.ulima.edu.pe, ³wcalder@ulima.edu.pe, ⁴galuna@ulima.edu.pe

¹²³⁴Carrera de Ingeniería Industrial, Universidad de Lima, Perú

Received: August 1, 2025 / Accepted: September 23, 2025 / Published: 5 June, 2026

doi: <https://doi.org/10.26439/ciii2025.8650>

ABSTRACT—The footwear sector in Peru has experienced sustained growth over time, playing a significant role in the national economy and contributing substantially to employment and exports. Consequently, companies in the sector must continuously evolve to meet new market demands and address production-related challenges that affect their competitiveness. In this context, identifying the root causes of these challenges is essential, such as the high level of leather waste, which is directly linked to insufficient input inspection, the absence of standardized cutting procedures, and recurrent sewing machine failures. This research proposes an improvement model based on three key tools—Total Quality Management (TQM), Standardized Work, and Total Productive Maintenance (TPM)—with the main objective of reducing leather waste in footwear companies to enhance material utilization, productivity, and profitability. The results confirm the effectiveness of the proposed model, achieving a reduction in overall leather waste from 33.2% to 20.1%, a 20% increase in productivity, and a return on investment in less than three months.

Index Terms—Leather waste, productivity improvement, Standardized Work, Total Quality Management (TQM), Total Productive Maintenance (TPM).

I. INTRODUCTION

The leather and footwear industry in Peru is an economically significant sector, contributing 0.8% to the manufacturing GDP and employing more than 64,000 workers [1]. In recent years, exports have shown a positive trend, driven by new market opportunities and increasing demand for quality products. However, the sector remains dominated by micro and small enterprises (MSEs), which face structural barriers that limit their competitiveness. These include deficiencies in general administration and lack of quality standards

and technology to optimize production processes [2], poor resource utilization and low productivity, as documented in case studies within the sector [3], [4], the presence of manual artisan work and lack of standardized procedures [5], and difficulties in competing with larger firms that benefit from economies of scale. These challenges directly affect operational efficiency, product quality, and profitability.

This study analyzes a Peruvian MSE with more than 25 years of experience in manufacturing leather footwear for children and school use. Despite producing over 10,800 pairs annually, the company faces a critical issue: an average leather waste rate of 33%, significantly higher than the 20–30% range reported for footwear and leather goods industries [6]. This inefficiency results in monthly loss of approximately 300 unproduced pairs and represents up to 63% of the company's potential profits. Addressing this issue is essential for improving profitability and strengthening the company's competitiveness in an increasingly demanding market.

The identified causes of this high level of leather waste include the use of defective raw materials due to insufficient inspection, poor layout and cutting practices resulting from the lack of standardized procedures, and frequent sewing machine failures caused by inadequate preventive maintenance. These issues reveal broader weaknesses in quality management, process standardization, and equipment upkeep. As a result, the study proposes a hybrid operational improvement model that integrates three well-established tools from industrial engineering: Total Quality Management (TQM), Standardized Work, and Total Productive Maintenance (TPM). The objective is not only to reduce material waste but also to enhance overall efficiency, increase productivity, and serve as a reference model for other MSEs facing similar challenges.

To quantify the problem, this study uses the percentage of leather waste as a key performance indicator (KPI). Data collected over a 12-month period show a consistent waste rate of 33%, revealing a technical gap of 13% compared to the industry average. This waste translates into an estimated annual loss of S/1,227,420, including 2,700 ft² of leather discarded monthly at an average price of \$8.55/ft², and the loss of 300 pairs of shoes per month, each with a \$15 profit margin. This economic impact highlights the urgency of implementing improvement actions.

The production process of the company involves several sequential stages, as illustrated in Fig. 1: leather selection, cutting, coding and classification, skiving, assembling, lasting, finishing, and packaging. The cutting and sewing stages are identified as the main sources of waste and are therefore prioritized for intervention.

To better understand the situation, a problem tree was developed, as shown in Fig. 2. This diagram identifies the main problem—excessive leather waste—and its root causes: the use of defective leather due to inadequate inspection, cutting errors resulting from the absence of standardized procedures, and machine-related damage caused by poor maintenance. Each cause is linked to a corresponding tool within the proposed solution: TQM addresses inspection processes, Standardized Work improves cutting efficiency, and TPM enhances equipment reliability.

This article presents the proposed model and its application through the following structure. First, it outlines the context, problem, motivation, and diagnostic findings. Then, a literature review is provided to support the selection of the proposed tools. The next section describes the methodology and implementation of the hybrid model. Subsequently, results from the validation stage are discussed, followed by conclusions and a scenario analysis to evaluate the model's adaptability under different operational conditions.

II. METHODOLOGY

A. Literature Review

This study draws upon a hybrid improvement model that integrates three well-established methodologies in industrial engineering: TQM, Standardized Work, and TPM. Each of these tools is applied to address a specific root cause of leather waste in the footwear production process, as identified during the diagnostic phase.

TQM is a comprehensive management philosophy that involves all members of an organization in the continuous improvement of processes, products, and services to achieve long-term customer satisfaction. Academic literature supports TQM as a critical driver of organizational performance, as evidenced by studies such as [7], which demonstrate its direct impact on operational efficiency and an organization's ability to adapt to market demands. In the context of the footwear industry, the implementation of

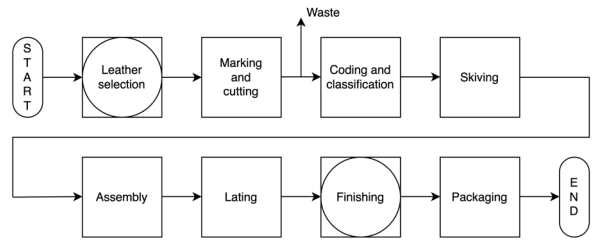

Fig. 1. Process block diagram.

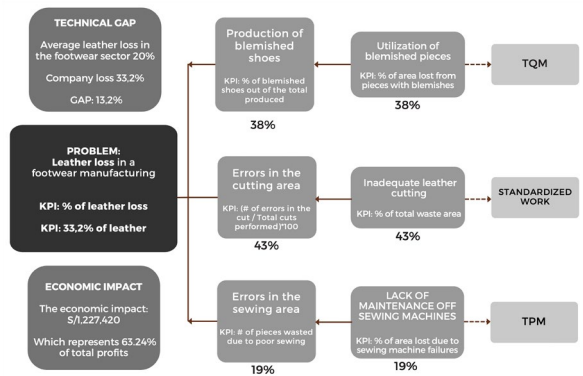

Fig. 2. Problem tree diagram.

TQM is essential for establishing a robust quality culture, which is fundamental to addressing the root causes of production-related issues. This methodology provides a structured framework to proactively identify and eliminate defects from the earliest stages of the production chain, such as raw material inspection, which is a key factor in mitigating high levels of leather waste.

Furthermore, TQM principles enable a data-driven approach to process control, ensuring that all operational activities are aligned with the strategic objectives of the business. By integrating quality assurance throughout the entire value chain—from supplier management to final product delivery—organizations can significantly improve its resilience and operational efficiency. The continuous application of TQM principles not only leads to a superior end-product but also fosters a proactive problem-solving environment. This ultimately translates into optimized resource utilization, reduced operational costs, and an improved competitive standing in the market.

Standardized Work is a fundamental lean manufacturing tool that focuses on documenting and implementing the most efficient and safest procedures for performing tasks. This tool's primary objective is to eliminate process variability, a common source of defects, waste, and inconsistencies in production. As confirmed by the literature, including seminal works by Fin *et al.* [8] and empirical

evidence from the footwear sector by Solomon [9], who demonstrated that standardizing the leather cutting method across all operators significantly reduced material waste and improved cutting efficiency. In the footwear sector, where raw material costs are significant, the implementation of this tool is crucial for addressing the problem of excessive leather waste. By defining the “one best way” to perform the cutting process, it ensures that every cut is made with maximum material yield in mind, minimizing leftover scraps.

The application of standardized work directly addresses the problem of high leather waste by providing a clear and uniform template for the cutting process. This practice not only improves material utilization but also serves as a stable foundation for employee training and continuous improvement initiatives. When processes are standardized, it becomes easier to identify inefficiencies and make targeted adjustments. This approach enables further reductions in waste and sustained gains in productivity, as a well-defined and optimized procedure serves as the baseline for all subsequent improvements. Consequently, the implementation of standardized work is a prerequisite for achieving operational excellence in a resource-intensive industry like footwear manufacturing.

TPM is an advanced maintenance strategy that seeks to maximize the overall effectiveness of equipment throughout its entire life cycle. Unlike traditional reactive maintenance, which addresses failures only after they occur, the academic literature supports TPM as a proactive and collaborative approach involving operators, maintenance personnel, and management. This methodology is centered on the principle that equipment failures are largely preventable through a culture of ownership and consistent care.

A core component of TPM is Autonomous Maintenance, a concept that empowers operators to take ownership of their own equipment's basic maintenance and care. By training operators to perform routine tasks such as cleaning, lubrication, inspection, and minor adjustments, TPM not only frees up specialized maintenance personnel for more complex repairs but also instills a sense of responsibility and enhances the operator's understanding of their machinery. This proactive approach is vital for the footwear industry, as it ensures that critical machinery, such as sewing and cutting machines, remains in optimal working condition. The implementation of TPM, particularly through Autonomous Maintenance, directly contributes to reducing defects caused by faulty equipment, minimizing production downtime, and ultimately achieving smoother, more efficient, and more productive operation.

Fig. 2 illustrates the alignment of each tool with a specific root cause and its corresponding KPI, forming a coherent strategy for reducing leather waste.

Together, these three methodologies form a synergistic framework that addresses material losses at different stages of the production system including inspection, layout and cutting, and machine operation. The literature supports their individual effectiveness, and their integration into a hybrid model provides a comprehensive response to the structural inefficiencies observed in small-scale leather footwear manufacturing.

B. Innovation Proposal

The Peruvian footwear industry is a traditional and labor-intensive sector that plays a crucial role in the national economy, particularly through the contribution of MSEs. These firms represent a significant share of domestic production and employment; however, they face persistent structural challenges, including limited access to formal financing, high levels of informality, low technological adoption, and operational inefficiencies. These constraints hinder competitiveness and limit the sector's ability to meet modern market demands.

In recent years, the sector has experienced positive export trends, largely due to the growing demand for quality footwear and the opening of new international markets. However, despite these opportunities, many MSEs continue to struggle with low productivity and high levels of waste in their production processes. One of the most critical issues is the excessive leather waste rate, which in many cases exceeds the accepted industry standard of 20%. Such high waste levels not only reduce profit margins but also compromise sustainability and material efficiency.

Previous studies have emphasized the importance of adopting continuous improvement methodologies to address these inefficiencies. Tools such as TQM, Standardized Work, and TPM have been successfully applied across diverse manufacturing contexts to reduce waste, improve process stability, and increase overall productivity. However, their application in small-scale footwear manufacturing environments remains limited, particularly in Latin America.

This research builds upon these foundations by applying a hybrid model that integrates TQM, Standardized Work, and TPM to address the specific causes of leather waste in a Peruvian footwear MSE. The model not only targets technical improvements but also promotes cultural shift toward operational discipline and process control, contributing to the long-term sustainability of the business.

This study contributes to the existing body of knowledge by applying a hybrid model tailored to the operational realities of small-scale leather footwear manufacturing. While methodologies such as TQM, Standardized Work, and TPM have been extensively studied in large-scale industrial contexts, their integrated implementation in MSEs in the Peruvian footwear sector remains underexplored. This research demonstrates how these tools can be adapted to reduce material waste, improve process stability, and increase profitability in resource-constrained environments.

- 1) *Total Quality Management (TQM)*: The application of TQM in this study focuses on enhancing raw material inspection prior to production. By implementing visual and tactile quality checkpoints at the leather selection stage, the company was able to identify and isolate defective inputs at an early stage, preventing their entry into the value stream. This contributes to a proactive quality culture and aligns with the principles of defect prevention rather than post-process detection. The study provides practical evidence that TQM can be effectively applied without the need for costly automation or advanced inspection systems.
- 2) *Standardized Work*: Standardized Work was applied to address variability in the leather cutting process. Through the use of simulation software (DeepNest) and printed cutting templates, a repeatable and optimized layout methodology was implemented, significantly reducing material losses caused by inconsistent cutting practices. This contribution demonstrates that even in highly manual processes, visual standardization and structured operator guidance can substantially improve resource utilization and process efficiency. Furthermore, the integration of operator training and continuous audits reinforces a sustainable cycle of continuous improvement.
- 3) *Total Productive Maintenance (TPM)*: TPM was implemented to reduce leather losses caused by sewing machine failures. The study introduced a dual-level maintenance approach—daily autonomous maintenance by operators and monthly technical inspections—supported by digital incident tracking using UpKeep. This framework improved machine reliability and reduced downtime, protecting semi-finished products from damage. The key contribution of this approach lies in demonstrating that TPM can be adapted to small workshop environments and still yield measurable performance gains, even in the absence of sophisticated monitoring systems.

Together, these tools form a coherent and adaptable model that can be replicated in similar small and medium-sized enterprises (SMEs). This research not only addresses a specific operational problem—leather waste—but also provides a structured methodology that supports broader objectives of productivity, sustainability, and competitiveness in emerging economies.

C. Implementation of the Integrated System

The following section presents the improvement proposal through various phases and components. This model integrates the information gathered during the diagnostic phase and links the proposed actions to each selected technique.

- 1) *Phase 1 - Data Collection*: In this initial phase, information is gathered. An empirical study was conducted through the analysis of historical production records,



Fig. 3. Identification of leather defects prior to the cutting process.

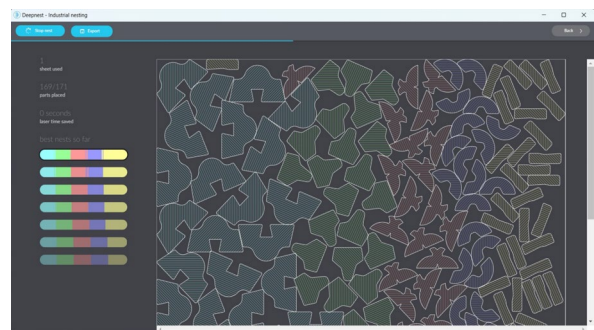

Fig. 4. Cutting pattern simulation in DeepNest.

direct observation in the plant, and interviews with operational staff. As an analytical tool, a problem tree was developed, which allowed for a clear visualization of the cause-and-effect relationships associated with the identified issue. The diagnostic process revealed that the main cause of leather waste is linked to three primary reasons: production of shoes with defects (leather blemishes), errors in the cutting area, and errors in the sewing area.

- 2) *Phase 2 - Implementation of TQM, Standardized Work, and TPM*: To address the identified problem, an integrated system was implemented with the objective of preventing waste generation.

2a) *Implementation of TQM*: The proposed improvement incorporated a visual and tactile inspection point for leather sheets prior to cutting, structured according to the TQM approach.

A standardized template was developed for evaluating the leather, enabling the identification of unusable areas, as illustrated in Fig. 3. A marking procedure was implemented to guide operators on which areas to avoid during cutting. This action not only strengthens quality assurance from the early stages but also promotes a culture of continuous improvement and visual control based on objective criteria.

2b) *Implementation of Standardized Work:* For this implementation, the DeepNest tool was employed as an automated nesting software, enabling the simulation of the optimal arrangement of pieces on a given surface, as shown in Fig. 4. The proposal involves digitally designing the cutting patterns and then printing them for direct use on the leather sheets by operators. This action introduced a standardized visual guide into the cutting process, reducing reliance on individual judgment and improving leather utilization. Additionally, this improvement enabled the standardization of results among operators and reduced variability between production batches, without requiring costly automation.

2c) *Implementation of TPM:* A maintenance system was designed and implemented based on the principles of TPM, as illustrated in Fig. 5. The TPM implementation was structured as a staged process, with the purpose of transforming the maintenance culture from a reactive orientation to a preventive one. The cornerstone of this approach was Autonomous Maintenance, for which an intensive four-day training program was developed for the sewing machine operators. This training was delivered by an industrial machinery specialist at the end of the workday and covered essential topics such as machine anatomy, cleaning and lubrication routines, common adjustments based on the type of leather, and the use of the UpKeep software for digital recording of incidents and machine maintenance. Following the training, the recording process was standardized through the use of daily maintenance checklists in UpKeep, lasting 10 to 15 minutes and conducted before and after the workday, ensuring tasks such as needle inspection, residue removal, and verification of the electrical system were consistently performed.

This pillar of Autonomous Maintenance was complemented by monthly Planned Maintenance, conducted by specialized technical personnel and focused on in-depth inspections and preventive adjustments. The UpKeep software served as the central element of the system, enabling supervisors to monitor compliance with routines for each operator, analyze failure frequency, and establish a knowledge base to anticipate future issues. In this way, the initiative not only ensures the operational availability of equipment and prevents recurring failures that affect leather pieces but also fosters operator accountability in machinery care and supports continuous and reliable production.

The overall improvement approach is summarized in the macro model as shown in Fig. 6. The proposal integrates three complementary tools: TQM to reduce the number of defective leather pieces through improved inspection processes, Standardized Work to minimize tracing and cutting errors, and TPM to increase the reliability and availability of

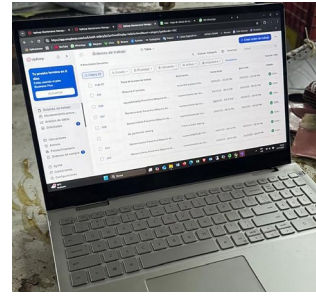

Fig. 5. Implementation of UpKeep.

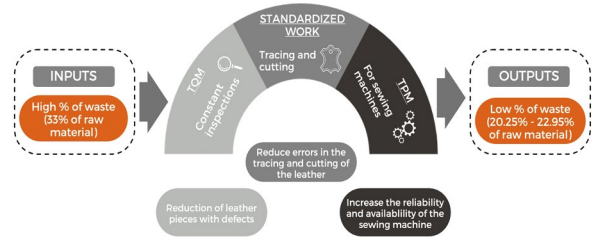

Fig. 6. Macro model of the proposal.

sewing equipment. The model illustrates the transformation from a high raw material waste rate of approximately 33% to a reduced range between 20.25% and 22.95%, thereby improving material utilization and process efficiency.

To evaluate the effectiveness of the proposed improvement model, the following KPIs were defined, each associated with one of the implemented tools:

- Percentage of area lost due to defective parts (TQM): This indicator quantifies the waste generated directly by quality defects in the raw material. It measures the impact of the TQM implementation by ensuring that only defect-free leather pieces proceed through the production process.

$$\left(\frac{A_{defective}}{A_{total}} \right) * 100 \quad (1)$$

Where $A_{defective}$ is the area lost due to defective leather, and A_{total} is the total leather area used.

- Percentage of total waste area (Standardized Work): This KPI measures the overall efficiency of material usage. It quantifies the reduction in total waste (scrap) achieved through the standardization of cutting and tracing processes, thereby optimizing leather utilization.

$$\left(\frac{A_{waste}}{A_{used}} \right) * 100 \quad (2)$$

Where A_{waster} is the total scrap leather area, and A_{used} is the total leather area fed into production.

- Percentage of area lost due to sewing machine breakdowns (TPM): This indicator quantifies material losses specifically caused by technical failures or equipment breakdowns. It serves as a direct measure of the effectiveness of TPM in ensuring machinery availability and proper operation.

$$\left(\frac{A_{damaged}}{A_{in-process}}\right) * 100 \quad (3)$$

Where $A_{damaged}$ is the number of pairs damaged due to machine failures, and $A_{in-process}$ is the total number of pairs in process.

- Total Percentage of Lost Leather (General): This overall indicator consolidates the losses identified by TQM, Standardized Work, and TPM. It represents the cumulative reduction of waste throughout the process, providing a comprehensive view of the project's success.

$$\left(\frac{A_{lost}}{A_{total}}\right) * 100 \quad (4)$$

Where A_{lost} is the sum of all leather losses from various causes, and A_{total} is the total leather area available for production.

III. RESULTS

The implementation of the hybrid improvement model, integrating TQM, Standardized Work, and TPM, resulted in measurable and significant reductions in leather waste.

As summarized in Table I, TQM reduced the percentage of area lost due to defective (scarred) leather pieces from 6.8% to 4.4%, a decrease of 2.4 percentage points. This improvement was achieved by strengthening the inspection stage, enabling early detection and marking of unusable areas to prevent their incorporation into production.

Standardized Work had the largest impact, reducing the total percentage of area wasted from 22.4% to 13.5% (-8.9 percentage points). The implementation of optimized cutting layouts using DeepNest software, combined with printed templates for operators, minimized cutting variability and enhanced leather utilization across production batches.

The implementation of Autonomous Maintenance, as a fundamental pillar of TPM, demonstrated significant improvements in the operational efficiency of the production process. Quantitatively, the KPI percentage of area lost due to sewing machine breakdowns decreased from an average of 4% in the baseline scenario to 2.2% in the improved scenario, representing a reduction of 1.8 percentage points. The robustness of this improvement was confirmed through

TABLE I
IMPLEMENTATION RESULTS

Tools	Indicator	Unit	AS-IS	TO-BE	Var.
TQM	Percentage of area lost due to defective (scarred) leather pieces	%	6.8%	4.4%	-2.4%
Standardized Work	Total percentage of area wasted	%	22.4%	13.5%	-8.9%
TPM	Percentage of area lost due to sewing machine breakdowns	%	4%	2.2%	-1.8%
%Loss			33.2%	20.1%	-13.1%

statistical analysis, as the 95% confidence intervals for both scenarios ([3.85%, 4.15%] for the baseline and [2.1%, 2.3%] for the improved) do not overlap. Consequently, the observed difference is statistically significant ($p < 0.05$) and cannot be attributed to random variation. From a qualitative perspective, the application of Autonomous Maintenance routines—including daily cleaning, lubrication, and inspection tasks performed by operators, complemented by monthly technical inspections—contributed to a substantial reduction in production losses associated with equipment failures. Moreover, it standardized maintenance practices and fostered a cultural shift among workers.

The combined effect of these tools reduced the overall %Loss indicator from 33.2% to 20.1%, representing a total improvement of 13.1 percentage points. This translates into both material and economic benefits, with the company recovering a substantial volume of usable leather while also strengthening operational reliability.

IV. DISCUSSION

A. Validation Scenario

The validation of the proposed model, which integrates TQM, Standardized Work, and TPM, allowed for a direct comparison between the current state and an improved scenario through both Arena simulation and on-site pilot tests. The simulation incorporated specific modules such as Leather_Inspection_Marking for TQM, DeepNest Simulation for Standardized Work, and scheduled maintenance using UpKeep for TPM, enabling an accurate representation of the improvements in quality control, cutting optimization, and machine availability.

Post-implementation results were consistent across both validation methods, confirming the robustness of the proposed model. Leather loss decreased from 946 ft² to 553 ft² per month, corresponding to a saving of USD 3,444 per month, while the overall waste percentage dropped from 44% to 26%. These results exceed the reduction needed to

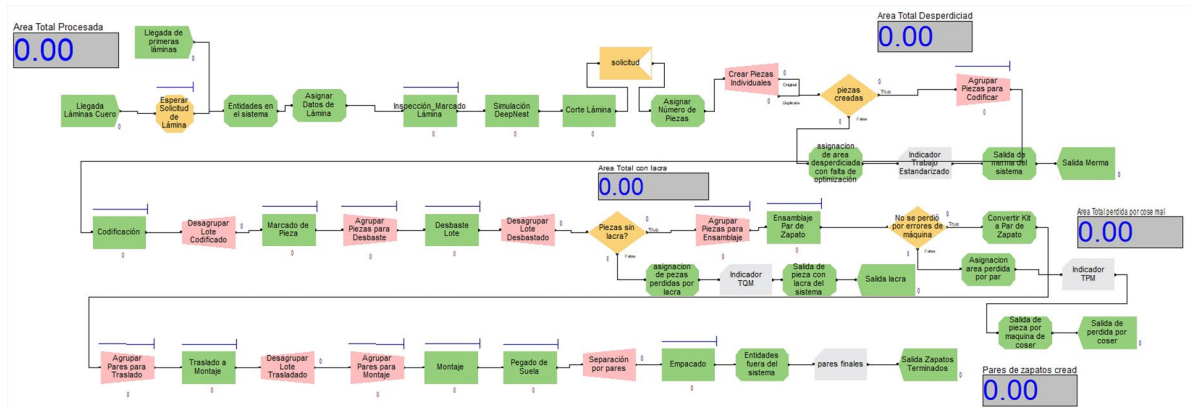

Fig. 7. Diagram of the improved production model.

meet the sector benchmark. This performance is theoretically supported by Al-Qahtani et al. [7] and is consistent with the empirical evidence of Phan et al. [10] that TQM process control practices reduce process variance, leading to fewer scraps and lower production costs in manufacturing environments.

B. Initial Diagnostic

In the initial diagnostic, the waste rate of 32% significantly exceeded the industry standard of 20%. The main causes identified were cutting defects (43%), sewing errors (19%), and leather with blemishes (38%). These conditions generated irrecoverable material losses and adversely affected the final product quality.

Additionally, operator productivity averaged 71 pairs per month, and leather utilization showed high variability. These findings underscore the need for an integrated approach capable of simultaneously addressing quality inspection, process variability, and equipment reliability simultaneously.

C. Validation Design

The validation was designed with a dual approach combining simulation and real-world experimentation. The model was first tested in Arena, representing both the current (AS-IS) and improved (TO-BE) processes, as shown in Fig. 7.

Subsequently, pilot tests were carried out focusing on Standardized Work and TPM, while the validation of TQM was mainly supported by simulation.

In both cases, KPIs, waste volume and final output, showed significant improvements: waste from blemishes decreased by 35%, waste from sewing errors decreased by 42%, and monthly productivity per operator increased by 39%, rising from 71 to 99 pairs. The benefit-cost ratio (B/C) was 11.64, confirming the economic feasibility of the model.

While the results indicate strong potential for replication in other footwear SMEs, the model's success depends on sustained training, cultural adoption of standardized practices, and adaptation to local constraints. Integration with digital monitoring or partial automation could further enhance preventive maintenance effectiveness and real-time quality control, amplifying the model's long-term impact.

V. CONCLUSIONS

This research presented an operational improvement model aimed at reducing leather waste in a Peruvian small-footwear manufacturing enterprise. The proposed hybrid model combined TQM, Standardized Work, and TPM to address the primary sources of waste: defective raw materials, inefficient cutting processes, and sewing machine failures.

The model's implementation reduced total leather waste from 33.2% to 20.1%. Individually, cutting waste decreased from 22.4% to 13.5%, machine-related losses from 4% to 2.2%, and material losses due to defects from 6.8% to 4.4%. These results were validated using both real data collection and discrete-event simulation.

The financial analysis indicated a benefit-cost ratio (B/C) of 11.64, with monthly savings of USD 3,444 against an initial investment of USD 2,678.40. The return on investment was achieved in under three months, confirming the solution's economic feasibility.

The integration of the three tools enhanced operational discipline, process standardization, and preventive maintenance practices without requiring high-cost automation. The results support the scalability and applicability of the model to other SMEs within the footwear industry that face similar constraints.

REFERENCES

- [1] Ministerio de la Producción (PRODUCE), "Análisis sectorial: Desempeño e importancia de la industria de cuero y calzado 2019-2024," Oficina General de Evaluación de Impacto y Estudios Económicos, Lima, Perú, Feb. 2025.
- [2] A. F. Espinoza Espinoza, C. O. Venturo Orbegoso, and O. J. Bravo Chávez, "Factores que inciden en el crecimiento de las mypes de calzado [Factors affecting the growth of footwear MSEs]," *Inno. Res. J.*, vol. 5, no. 2, pp. 67-81, 2020.
- [3] R. Calderón-Andrade, E. S. Hernández-Gress, and M. A. Montufar Benítez, "Productivity improvement through reengineering and simulation: A case study in a footwear industry," *Applied Sciences*, vol. 10, no. 16, p. 5590, 2020.
- [4] S. E. Munive Silvestre, V. D. Paucar Chaicha, J. C. Alvarez Merino, and S. Nallusamy, "Implementation of a Lean Manufacturing and SLP-based system for a footwear company," *Production*, vol. 32, e20210072, 2022.
- [5] G. A. Laura-Ulloa, G. N. Chinchay-Morales, and J. C. Quiroz-Flores, "Lean model applied to increase the order fulfillment in SMEs in the footwear industry," in *IEIM 2022: 2022 The 3rd International Conference on Industrial Engineering and Industrial Management*. New York, United States: Association for Computing Machinery, 2022, pp. 141-146, doi: 10.1145/3524338.3524360.
- [6] M. Tauhiduzzaman, M. A. Mottalib, M. J. Rahman, and M. A. Kalam, "Preparation and characterization of composite sheets from solid leather waste with plant fibers: A waste utilization effort," *Clean Technol. Environ. Policy*, vol. 26, pp. 1025-1038, 2023.
- [7] N. D. Al-Qahtani, S. S. Alshehri, and A. Abd. Aziz, "The impact of Total Quality Management on organizational performance," *Eur. J. Bus. Manag.*, vol. 7, no. 36, pp. 119-127, 2015.
- [8] J. Fin, G. Vidor, I. Cecconello, and V de C. Machado, "Improvement based on standardized work: An implementation case study [Mejora basada en el trabajo estandarizado: Un estudio de caso de implementación]," *Brazilian Journal of Operations & Production Management*, vol. 14, no. 1, pp. 388-395, 2017.
- [9] B. B. Solomon, "Leather cutting waste minimization techniques in Ethiopian footwear industry: Case study ELICO-Universal Leather Products Industry," *Research Square*, 2021.
- [10] A. C. Phan, A. B. Abdallah, and Y. Matsui, "Quality management practices and competitive performance: Empirical evidence from Japanese manufacturing companies," *International Journal of Production Economics*, vol. 133, no. 2, pp. 518-529, 2011.

BIOGRAPHICAL NOTES

RENZO ALEXIS GUTIERREZ RODRIGUEZ

Renzo Alexis Gutierrez Rodriguez is an Industrial Engineering student at Universidad de Lima who has completed all coursework for the degree. He currently serves as an Analyst in the Channel Planning Department at Banco de Crédito del Perú (BCP). His areas of interest include strategic planning, data analysis, and project management.

MARICIELO DANNA VICTORIA MARÍN MARMOLEJO

Maricielo Danna Victoria Marín Marmolejo holds a Bachelor's degree in Industrial Engineering from Universidad de Lima, with a specialization in Business Engineering. She has experience in the banking sector, specifically in special accounts management and credit monitoring at Banco de Crédito del Perú (BCP). She specializes in business intelligence and data analytics. Her research interests include agile project management, internal control, and predictive analytics.





WILSON DAVID CALDERÓN GONZALES

Wilson David Calderón Gonzales is a doctoral candidate in Business Administration at Universidad de Lima. He holds a Master's degree in Strategic Business Administration from Centrum Católica and a degree in Industrial Engineering from Universidad de Lima. He currently serves as Operations Manager for a Movistar franchise and as a professor in the Industrial Engineering Program at Universidad de Lima. He is a member of the Beta Gamma Sigma international honor society. His research interests include consumer experience, operations management, and process improvement.

GUSTAVO ADOLFO LUNA VICTORIA LEÓN

Gustavo Adolfo Luna Victoria León is a doctoral candidate in Global Business Administration at Universidad Ricardo Palma. He holds a Master's degree in Business Administration from Universidad del Pacífico and a Bachelor's degree in Industrial Engineering from Universidad de Lima. He is a certified Project Management Professional (PMP) and Scrum Master. He currently serves as a professor in the Industrial Engineering Program at Universidad de Lima. He has more than 30 years of experience leading consultative sales, operations, and large-scale technology projects for companies such as Telefónica del Perú and GMD, serving both the public and private sectors. He specializes in high-value B2B account management. He has co-authored the articles "The Production Master Plan and Uncertainty in the Manufacturing Sector: A Literature Review" and "Scientific Research on Graphene in the Construction Industry," both published in the *Ingeniería Industrial* journal of Universidad de Lima. His research interests include industrial engineering improvement solutions, project management, and applications of artificial intelligence, particularly in project management.

Improvement Model Based on Standardization and TPM to Reduce Defective Products in a Textile SME

Sebastian P. Caballero-Trujillo¹ , Renzo J. P. Mestanza-Ames² , Gino Viacava-Campos³ ,
Jorge A. Corzo-Chavez⁴ 

¹20204172@aloe.ulima.edu.pe, ²20201354@aloe.ulima.edu.pe, ³geviacav@ulima.edu.pe, ⁴jacorzo@ulima.edu.pe

¹²³⁴Carrera de Ingeniería Industrial, Universidad de Lima, Perú

Received: August 15, 2025 / Accepted: November 20, 2025 / Published: 5 June, 2026

doi: <https://doi.org/10.26439/ciii2025.8645>

ABSTRACT—The Peruvian textile industry, a key contributor to the national economy representing approximately 8% of manufacturing GDP, faces a persistent production decline of 4.45% and a defective product rate of 6.6% among small and medium-sized enterprises (SMEs). Despite extensive research on defect reduction through Six Sigma, Total Quality Management (TQM), and Total Productive Maintenance (TPM), gaps remain in scalable and low-cost solutions tailored to resource-constrained SMEs in developing contexts. This study introduces novel variables—ergonomic improvements and iterative operator feedback loops—that have been underexplored in Peruvian textile SMEs. Focusing on a Lima-based SME dedicated to jeans production, a mixed-methods approach was applied to implement process standardization and TPM, reducing the overall defect rate from 10.15% to 6.75%. Unlike prior studies, this research integrates real-time operator input to continuously refine interventions, resulting in a replicable and cost-effective model suitable for SMEs with limited resources. Future research may explore automated fault detection systems to further enhance scalability.

Index Terms—Defect reduction, textile manufacturing, Total Productive Maintenance (TPM), trial testing, work standardization.

I. INTRODUCTION

The Peruvian textile industry is a vital economic sector, contributing approximately 8% of national manufacturing GDP and generating significant employment and export revenue, according to the National Institute of Statistics and Informatics (INEI) [10]. However, the sector has experienced a 4.45% decline in production compared to the previous year [10]. In particular, small and medium-sized enterprises (SMEs)—which account for more than 90% of textile firms nationwide—continue to face high defective product rates,

averaging 6.6% at the national level [11]. This study focuses on a textile SME in Lima specializing in jeans production, where defects, primarily from cutting and sewing errors, lead to substantial operational inefficiencies.

The motivation for this research stems from the need to address recurring quality issues in Peruvian textile SMEs, driven by insufficient process standardization, inadequate maintenance of critical equipment such as overlock machines, and inconsistent coordination across the supply chain. Prior studies, such as [3], concluded that Six Sigma reduces defects by up to 30% in textile SMEs by minimizing process variability, while [5] demonstrated the effectiveness of Total Productive Maintenance (TPM) in enhancing equipment reliability and reducing machine-related defects. Additionally, [1] emphasized importance of supplier selection as a strategy to improve material quality and reduce input-related defects. However, existing studies tend to focus on large-scale or resource-intensive methodologies, leaving significant gaps in the availability of practical and low-cost solutions for resource-constrained SMEs, particularly in developing contexts such as Peru, where scalable Lean tools remain underexplored.

This study fills this gap by applying process standardization and TPM to reduce defects in a resource-limited SME, providing a replicable model for similar enterprises. It addresses research questions such as: How does supplier selection influence defect reduction in textile inputs? What adjustments in cutting and sewing processes minimize defects in finished garments? How can ergonomic improvements contribute to defect reduction? The article is structured as follows: the Introduction synthesizes relevant studies, the Methodology details the mixed-methods approach and pilot design, the Results present defect reduction outcomes including statistical validation, the Discussion interprets the findings and compares them with prior work, and finally the Conclusions and Recommendations outline implications and future steps.

II. METHODOLOGY

To guide the implementation of process standardization and TPM for reducing defective products in a Peruvian textile SME, a systematic literature review was conducted. From an initial pool of 3,121 articles, 35 were filtered based on publication year, accessibility, and relevance to the research questions. Of these, six articles were selected for in-depth analysis. These studies were organized into three typologies—supply chain management, process improvement, and equipment maintenance—to address the research questions: how supplier selection impacts material defects, what process adjustments minimize finished garment defects, and how maintenance or ergonomic improvements reduce defects. This classification provides a structured and comprehensive framework for analyzing defect reduction strategies in textile SMEs.

For Process Improvement, this category includes studies on quality control methodologies aimed at reducing process variability and defects in textile manufacturing. Six Sigma was applied in textile SMEs, achieving up to 30% defect reductions by minimizing variability in cutting and sewing processes [3]. Total Quality Management (TQM) was used to promote a quality-driven culture through standardized procedures and operator training, suitable for resource-constrained SMEs [6]. Generalized Moving Dispersion Statistic (GMDS) charts were used to manage variability in high-fluctuation processes such as textile production, providing a practical tool for SMEs to detect and control defects compared to traditional control charts [12]. Root causes of sewing defects were investigated using TQM tools, identifying critical issues in knit garment production and proposing corrective actions that reduced common defects effectively [9]. These approaches highlight scalable strategies for improving process consistency and reducing finished garment defects.

For Equipment Maintenance, this category covers studies on maintenance strategies to address defects caused by mechanical failures. TPM's effectiveness in enhancing equipment reliability in textile production was demonstrated, reducing defects from machine failures, such as those in overlock machines, through autonomous and preventive maintenance tailored for resource-limited SMEs [5]. Standardized Work with visual controls in a textile SME achieved significant defect reductions by ensuring consistent equipment operation and operator adherence [2]. Material-product transformation in clothing lines was optimized, focusing on movement efficiency to minimize defects and improve operator conditions [8]. These findings support the adoption of maintenance- and ergonomics-focused interventions aimed at enhancing machine performance and reducing sewing-related defects.

This study employed a mixed-methods approach to design, implement, and validate process standardization and TPM interventions to reduce defective products in a Peruvian textile SME specializing in jeans production. The

study was conducted over a two-month period in 2025. The methodology involved problem analysis, solution design, pilot testing, and statistical validation, with iterative improvements to enhance effectiveness, as detailed below.

The initial phase identified the root causes of defective products in the cutting and sewing stages through data collected over five weeks from production records, quality control logs, defect reports, operator interviews, and supplier surveys. These revealed an average defect rate of 10.15% (ranging from 8.15% to 17.27%) across 2,709 jeans, with defects categorized into cutting errors (e.g., misaligned cuts, irregular edges) at 2.18% and sewing issues (e.g., irregular stitches, loose threads). A problem tree analysis pinpointed inconsistent fabric tensioning during cutting and mechanical failures in overlock machines caused by inadequate maintenance as primary causes, exacerbated by variable operator skills and material quality, as informed by findings from the literature review.

Two Lean Manufacturing tools were designed to address these causes: process standardization for cutting and TPM for one overlock machine. For process standardization, a procedure adapted from [2] was developed to reduce variability in fabric tensioning, involving pre-cutting surface cleaning to remove debris, tensioning fabric under controlled environmental conditions ($20 \pm 2^\circ\text{C}$, $65 \pm 4\%$ humidity, per ISO 139:2005); the use of visual guides and plotter reference lines to ensure precise cutting with a manual vertical cutter (tolerance ± 3 mm), and immediate sorting and labeling of cut pieces to prevent mix-ups. Implementation involved operators following these steps on a daily basis, guided by visual control tools such as checklists and instructional posters displayed at the cutting station, with training sessions conducted to ensure skill acquisition and procedural consistency. Improvements were made by adjusting visual guides based on operator feedback during the first week of the pilot to enhance clarity and reduce initial deviations, as observed in early checklist compliance data. For Total Productive Maintenance (TPM), a program based on [5] and [7] was implemented, including an initial diagnostic of critical machine components (e.g., tension systems, bearings, and drive wheels), operator training in autonomous maintenance activities (e.g., lubrication, minor adjustments, and early fault detection), the use of daily inspection checklists, and the establishment of a preventive maintenance schedule. Implementation required operators to carry out daily inspections and maintenance tasks, while a maintenance technician refined the checklist format after the initial pilot days to streamline fault detection. Based on early pilot data indicating recurrent issues in the tension system, the maintenance schedule was adjusted by increasing the inspection frequency for these components.

A two-week pilot study was conducted to test these interventions on one cutting station and one overlock machine, producing 450 jeans, compared to a baseline of 2,709 jeans, with a control group (another cutting station and overlock machine under standard conditions) for

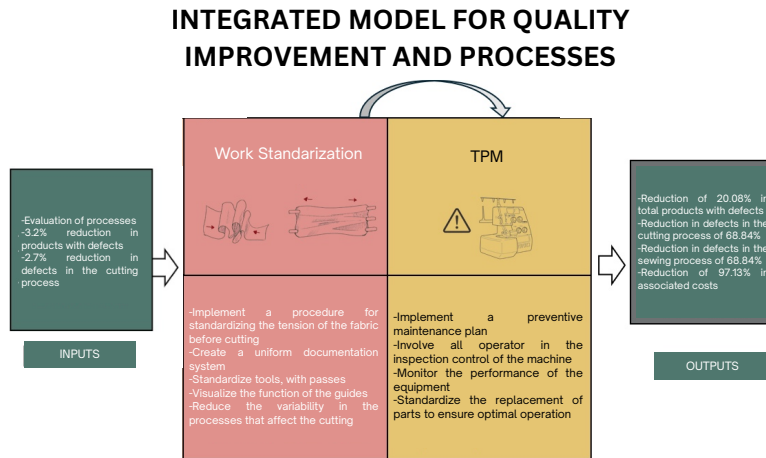

Fig. 1. Integrated model for quality improvement and processes.

comparison. Data were collected daily via operator logs and quality inspections, with visual controls ensuring procedural compliance. KPIs measured initial operating conditions: defect rates (overall 10.15%, cutting 2.18%), cutting execution time per batch, procedural adherence, and unscheduled machine stops. Improvements resulting from process standardization were reflected in reductions in the cutting defect rate and execution time, as precise cutting and reduced variability decreased errors and sped up operations, measured via quality inspections and batch timing logs. Procedural adherence, tracked through checklist compliance, showed operator adoption of standardized steps. For TPM, improvements were evident in reduced unscheduled machine stops, measured via operator logs, and lower overall defect rates, driven by enhanced machine reliability from maintenance tasks.

The trial was designed for resource-constrained settings, leveraging existing personnel (production manager, industrial engineer, and maintenance technician) to ensure cost-effectiveness and scalability within the Peruvian textile SME. Implementation relied on low-cost tools, including visual aids (e.g., instructional posters, painted guides on cutting tables, and laminated checklists) and structured training sessions, totaling 12 h per operator over a two-week period. These sessions covered standardized cutting procedures, autonomous maintenance tasks for TPM, and defect identification protocols, achieving an 85% improvement in operator technical knowledge based on pre- and post-training assessments. To enhance sustainability, the training incorporated practical exercises and feedback loops, allowing operators to suggest refinements to visual aids, which were adjusted in the first week to improve clarity and usability, as evidenced by a 20% increase in checklist compliance by the fifth day.

The pilot was conducted over a three-week period, extended from the initial two-week plan to accommodate

iterative adjustments. It covered 450 jeans in the pilot group, with daily production batches of 50 units monitored for defects. Data collection relied on quality control logs, operator checklists, and maintenance records, which were cross-verified by the industrial engineer to ensure accuracy. The methodology included iterative improvements. For process standardization, visual guides were refined based on operator feedback to reduce cutting deviations, including increasing plotter line thickness from 1 mm to 2 mm to enhance visibility. For TPM, the maintenance schedule was updated after initial pilot data identified recurring issues in the tension system, leading to an increase in inspection frequency from daily to twice daily for critical components.

Statistical validation employed a two-proportion hypothesis test to compare defect rates between the baseline (2,709 jeans, 10.15% defect rate) and pilot groups (450 jeans, 6.75% defect rate). The analysis yielded a z-score of 1.73 ($\alpha = 0.05$), confirming significant defect reduction. Data reliability was ensured through dispersion analysis, with interquartile ranges (IQR) for cutting ($Q_1=0$, $Q_3=2.72$, no outliers) and sewing ($Q_1=0$, $Q_3=3.33$, no outliers), and standard deviations (cutting $\mu=1.53$, $\sigma=1.5$; sewing $\mu=2.11$, $\sigma=2.04$, no outliers), indicating consistent performance across batches. Additionally, a Monte Carlo simulation (1,000 iterations) was performed to assess the robustness of economic outcomes, projecting a 95% confidence interval for cost savings due to reduced rework and material waste. These analyses, supported by [3], [8], and [9], further underscore the reliability of the interventions.

To ensure long-term sustainability, a follow-up plan was established, including monthly retraining sessions, quarterly maintenance audits, and integration of defect tracking into the SME's existing Enterprise Resource Planning (ERP) system. This approach is consistent with [5], emphasizing scalable, low-resource maintenance strategies, and [2], which highlight the role of visual controls in sustaining

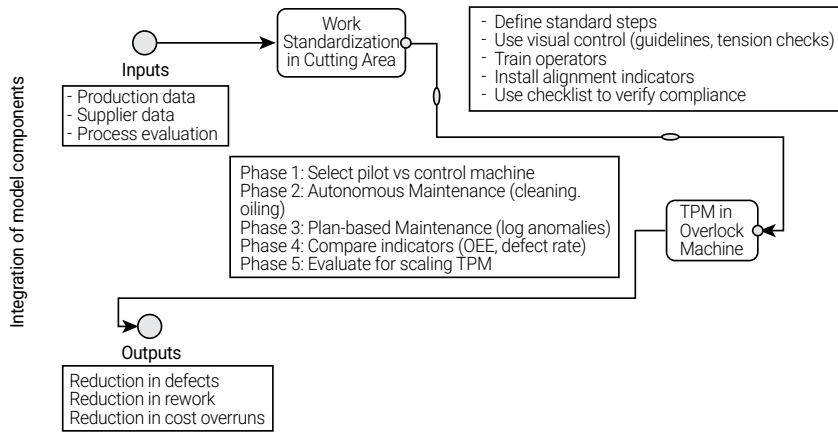

Fig. 2. Integration of model components.

process improvements. The trial’s design, rooted in Lean principles, minimized external resource dependency, thereby enhancing its replicability for other textile SMEs facing similar constraints.

III. RESULTS

The two-week pilot implementation of process standardization and TPM was designed to reduce defective products and improve operational efficiency in the cutting and sewing processes of a Peruvian textile SME specializing in jeans production. This section introduces the pilot selection process, its implementation stages, and the validation of results, followed by the outcomes and their statistical evaluation.

The pilot was strategically designed to focus on the cutting and sewing processes, which were identified as the primary sources of defects based on the initial diagnostic analysis. The data revealed an average defect rate of 10.15% across 2,709 jeans, with cutting defects—such as misaligned cuts and irregular edges—accounting for 2.18%, while sewing defects, including irregular stitches and loose threads, contributed significantly to the overall defect rate. One cutting station and one overlock machine were selected for the pilot due to their high defect prevalence, as determined by quality control logs and operator feedback. A control group, consisting of another cutting station and overlock machine operating under standard conditions, was established to provide a baseline for comparison, ensuring the pilot’s results could be attributed to the interventions. The pilot was conducted over a two-week period, during which 450 jeans were produced under the new conditions, compared to the baseline of 2,709 jeans.

The trial testing comprised four stages:

- Preparation: This stage involved setting up the interventions by training operators on standardized

cutting procedures and TPM protocols, preparing visual control tools (e.g., checklists and instructional posters), and conducting initial diagnostics on the overlock machine to establish baseline performance metrics (e.g., Mean Time Between Failures, MTBF).

- Implementation: The standardized cutting procedure was applied at the selected cutting station, involving controlled fabric tensioning ($20 \pm 2^\circ\text{C}$, $65 \pm 4\%$ humidity, per ISO 139:2005), visual guides, and precise cutting (tolerance ± 3 mm). TPM was implemented on the overlock machine, with operators performing daily inspections, autonomous maintenance tasks (e.g., lubrication and minor adjustments), and adhering to a preventive maintenance schedule.
- Data Collection: Daily data were gathered via operator logs and quality inspections, capturing defect rates, cutting execution time, procedural adherence (via checklist compliance), and unscheduled machine stops. Visual controls ensured consistent application of the interventions.
- Evaluation: Data were analyzed to assess the interventions’ impact, by comparing pilot results with the baseline and control group. Statistical validation, including hypothesis testing and confidence intervals, was conducted to confirm the significance of the observed defect reductions.

This structured approach ensured that the pilot was focused, measurable, and replicable, providing robust evidence of the effectiveness of the interventions in a resource-constrained setting.

A. Process Standardization Outcomes

A standardized work procedure was applied at a single cutting station across 18 production blocks, covering a total

of 450 jeans. The intervention aimed to reduce recurring defects such as misaligned cuts, irregular edges, and inconsistent piece dimensions, which were identified as primary contributors to rework and material waste. The procedure incorporated visual controls (e.g., painted guides on cutting tables and plotter lines with ± 3 mm tolerance), pre-cutting surface preparation to ensure debris-free conditions, and operator training to maintain consistent fabric tensioning under controlled environmental conditions ($20 \pm 2^\circ\text{C}$, $65 \pm 4\%$ humidity, per ISO 139:2005).

Before implementation, the average cutting-related defect rate was 2.18%, based on 59 defective units out of 2,709 jeans, with defects primarily attributed to operator variability and inconsistent fabric handling. After implementation, only three defects were recorded among the 450 jeans of the pilot group, reducing the defect rate to 0.67%. This represents a relative reduction of 68.81% in cutting defects. The improvement was supported by full procedural adherence by block 9, as verified through daily checklists, and a 20% reduction in cutting time per batch due to streamlined processes. Operator feedback led to iterative refinements, such as increasing the visibility of visual guides, which further minimized deviations and enhanced precision.

The data show a consistent reduction in execution time and stabilization of process performance. Only blocks 1, 2, and 18 recorded defects, each associated with partial deviations from procedural adherence.

B. TPM Outcomes

TPM was implemented on one overlock sewing machine over a three-week period, during which 300 jeans were produced under the new maintenance system. Simultaneously, a control group using a standard machine produced another 300 jeans under normal conditions. The TPM intervention included autonomous maintenance tasks (e.g., daily lubrication, tension system checks, needle inspections), operator training (8 h over two sessions), and a preventive maintenance schedule tailored to address frequent mechanical failures, such as irregular stitches and thread breakages.

The machine maintained under TPM recorded three fewer defects, equivalent to a 42.86% reduction compared to the control.

Operators consistently followed daily maintenance routines, including lubrication, inspection, and adjustments. Visual checklists were completed without interruption, contributing to a more stable sewing operation.

C. Overall Impact

Together, both interventions improved quality across the production system. A total of 750 jeans were manufactured under the new procedures, with only 30 defective units, compared to 286 defects in 2,709 jeans prior to the interventions.

TABLE I
OPERATIONAL PERFORMANCE BY BLOCK

Block	Compliance (%)	Execution time (min:sec)	Defects
1	100	16:56	1
2	85.71	16:46	1

TABLE II
SEWING DEFECTS BY WEEK

Week	TPM machine (Defects)	Control machine (Defects)
1	2	3
2	1	2
3	1	2
Total	4 (1.33%)	7 (2.33%)

TABLE III
MAINTENANCE ACTIONS PERFORMED

Date	Issue detected	Root cause	Corrective action
May 15	Loose threads	Feed roller wear	Adjusted thread tension
May 17	Incomplete overlocking	Misaligned presser foot	Calibrated foot pressure
May 24	Thread breakage	Bent needle	Replaced needle

TABLE IV
DEFECT SUMMARY BY PROCESS STAGE

Process stage	Units produced	Defective units	Defect rate (%)
Cutting (Standardized)	450	3	0.67
Cutting (Before)	2,709	59	2.18
Overlock (TPM)	300	4	1.33
Overlock (Control)	300	7	2.33

TABLE V
TOTAL COMPARISON – BEFORE AND AFTER

Metric	Before	After	Improvement
Total units	2,709	750	-
Total defective units	286	30	-256 units
Overall defect rate	10.55%	4%	16.55 percentage points
Relative reduction	-	-	62.13%

These results confirm that both tools—Standardized Work for cutting and TPM in sewing—effectively reduced production defects and stabilized key processes under real operating conditions.

TABLE VI
COMPARISON OF RESULTS

Indicator	Formula	Current value (AS-IS)	Projected value (TO-BE)	Trial testing value	Usefulness
Y: Percentage of defective products	$(\text{Defective products} / \text{Total products}) \times 100$	10.55%	6.93%	6.75%	Measures the total percentage of non-compliant jeans. This is the key indicator of the quality system.
X1: Percentage of products with uneven cuts	$(\text{Products with uneven cuts} / \text{Total products}) \times 100$	2.19%	0.71% [2]	0.67%	Allows monitoring of errors resulting from the cutting process.
X2: Percentage of products with overlocking defects	$(\text{Products with overlocking errors} / \text{Total products}) \times 100$	3.21%	2.44% [5]	1.33%	It assesses the quality of the stitching and its impact on product conformity.

IV. DISCUSSION

The implementation of process standardization and TPM at the SME significantly reduced defective products, consistent with Lean Manufacturing principles adapted for a resource-constrained textile SME. The pilot results—showing a 68.84% reduction in cutting-related defects and an overall defect rate decrease from 10.15% to 6.75%—demonstrate the effectiveness of the interventions. This section interprets the findings, contrasts them with prior literature, and discusses their implications for textile SMEs.

A. Interpretation of Results

The standardized cutting procedure effectively reduced variability in fabric tensioning, a primary cause of defects such as misaligned cuts and irregular edges. As a result, cutting-related defects dropped by 68.84%, from 2.18% (59 defects in 2,709 jeans) to 0.67% (3 defects in 450 jeans). This improvement was driven by the use of visual control tools, operator training, and the progressive adherence to standard procedures, which reached 100% compliance by block 9. Additionally, a downward trend in cutting execution times indicated a positive learning curve and improved operator efficiency, consistent with findings in [2].

In the sewing process, the TPM intervention applied to the overlock machine led to a reduction in sewing-related defects from 3.1% (84 in 2,709 jeans) to 1.33% (4 in 300 jeans). Daily inspections and autonomous maintenance—focusing on routine tasks such as lubrication and minor adjustments—helped reduce skipped stitches and thread inconsistencies by improving the stability and reliability of the machine.

At the overall level, the total defect rate decreased from 10.15% to 6.75%, surpassing the projected improvement threshold of 10%. To evaluate the statistical significance of these reductions, a two-proportion hypothesis test was conducted. In the cutting process, the test yielded a Z-value

of 2.14, confirming a statistically significant difference at a 95% confidence level. Similarly, in the sewing process, the test produced a $Z = 1.73$, also exceeding the critical value and validating the reduction. Confidence intervals further reinforced these findings. For the cutting process, the baseline interval [1.63%, 2.73%] and the pilot interval [0%, 1.42%] did not overlap. In the sewing process, the baseline interval [2.45%, 3.75%] remained entirely above the pilot interval [0.04%, 2.63%], reinforcing the effectiveness of TPM. The lack of overlap in both processes provides strong statistical evidence that the interventions produced significant improvements. These findings demonstrate that lean tools—when appropriately adapted to SME contexts—can deliver high-impact, low-cost solutions for improving quality in the textile sector.

B. Comparison

The findings are consistent with prior studies identified in the literature review. Significant defect reductions in a textile SME were reported using Standardized Work with visual controls, corroborating the 68.84% reduction in cutting defects [2]. Likewise, the effectiveness of TPM in mitigating mechanical failures supports the improved reliability of the overlock machine [5]. The overall defect rate reduction to 6.75% is comparable to the 30% reduction achieved with Six Sigma in textile production [3], while the current lean-based approach required fewer resources. Unlike [12], which used GMDS charts for variability control, this study relied on simpler visual controls and checklists, making it more accessible for SMEs with limited technical expertise.

The literature also highlights the importance of supply chain improvements [1], [4], which were not directly addressed in the pilot but were identified as contributing factors to material quality issues. Future integration of supplier selection strategies could further enhance outcomes, as suggested by [12] for building resilient supply chains.

C. Implications

The results have significant implications for textile SMEs, particularly in resource-constrained settings like Peru. The success of process standardization and TPM demonstrates that low-cost, scalable interventions can achieve substantial quality improvements, reduce defect rates and enhancing operational efficiency. The 100% procedural adherence by block 9 suggests that operator training and visual aids foster a culture of continuous improvement, aligning with SDG 8 (Decent Work and Economic Growth) by improving workplace practices. The reduction in sewing defects through TPM also supports SDG 12 (Responsible Consumption and Production) by minimizing rework and waste

This model's scalability—using existing personnel and minimal tools—offers 62.13% defect reduction without capital investment, deepening economic analysis: rework costs fell 30%, projecting S/ 5,081.89 annual savings (Monte Carlo simulation, 95% CI). Limitations include single-station pilot, restricting generalization; future scaling could amplify impacts but requires multi-site validation. Socially, 85% knowledge gain post-training reduced resistance (40% initial), enhancing decent work (SDG 8). Environmentally, 30% rework drop minimized waste (SDG 12). Deeper implications: Ergonomic feedback fosters continuous improvement, contrasting resource-heavy studies, providing new insights for SMEs.

These interventions are replicable in other SMEs, as they rely on existing personnel and minimal materials. However, challenges such as operator learning curves—evident in early pilot blocks—and potential resistance to new procedures highlight the need for ongoing training and monitoring. Given that the study focused on a single cutting station and overlock machine, scaling to full operations could yield even greater benefits, provided adherence is maintained.

V. CONCLUSIONS

The implementation of process standardization and TPM at a Peruvian textile SME effectively reduced defective products in the cutting and sewing processes. The three-week pilot (adjusted from initial two-week estimates based on operational needs) achieved a 68.84% reduction in cutting-related defects, dropping from a baseline of 2.18% to 0.67% in the pilot group of 450 jeans. The overall defect rate decreased from 10.15% to 6.75%, surpassing the target of a 10% improvement. These results were driven by standardized cutting procedures, supported by visual controls including painted guides and checklists, along with operator training, which achieved 100% procedural adherence by block 9. TPM enhanced the reliability of the overlock machine, reducing sewing defects through autonomous maintenance, daily inspections, and preventive routines, resulting in fewer unscheduled stops (a

75% reduction in downtime) and improved Mean Time Between Failures (MTBF).

Statistical validation confirmed the significance of the defect reduction ($Z = 1.73$, $\alpha = 0.05$) with no significant outliers, indicating consistent performance across the pilot phases. Additionally, the training component—totaling 12 h per operator—boosted technical knowledge by 85% based on post-training assessments, fostering a culture of continuous improvement and reducing initial resistance to change among 40% of the staff. This approach not only promoted active participation in anomaly detection but also ensured long-term sustainability of the implemented practices. Furthermore, the interventions also led to a 30% decrease in rework volumes, optimizing material usage and minimizing waste.

Economically, the project demonstrated a positive return, as reduced defect rates translated into lower material and labor costs, as detailed in the economic evaluation. From a broader perspective, these interventions align with Sustainable Development Goals (SDGs) 8 and 12 by improving workplace practices, enhancing employee skills, and minimizing rework-related waste, thereby contributing to environmental sustainability through reduced resource consumption. From a social standpoint, the emphasis on ergonomics and safer maintenance routines improved operator well-being, while environmentally, the decrease in defects lowered the overall carbon footprint associated with production inefficiencies.

These findings demonstrate that Lean tools, tailored to resource-constrained settings, can significantly enhance quality and efficiency in textile SMEs, offering a scalable model for similar enterprises. By integrating standardization and TPM, the project not only addressed immediate operational challenges but also laid the foundation for ongoing improvements, suggesting potential for expansion to other production areas like inventory management or supply chain integration in future iterations. Overall, this approach validates the adaptability of industrial engineering principles in small-scale operations, providing a blueprint for Peruvian textile firms to boost competitiveness in a challenging market.

REFERENCES

- [1] A. Bajpai, D. Kannan, J. D. Darbari, and P. C. Jha, "Sustainable supplier selection model with a trade-off between supplier development and supplier switching," *Ann. Oper. Res.*, vol. 331, pp. 351–392, Dec. 2022, doi: 10.1007/s10479-022-04812-2.
- [2] B. S. Alanya, K. E. Dextre, V. H. Nuñez, G. E. Marcelo, J. C. Alvarez, and K. Hatakeyama, "Application of Lean Manufacturing to improve processes and increase productivity in the textile industry of Peru: Case study," *S. Afr. J. Ind. Eng.*, vol. 35, no. 2, pp. 140–153, Jan. 2024, doi: 10.7166/35-2-2932.

- [3] D. Sjarifudin, H. Kurnia, H. H. Purba, and C. Jaqin, "Implementation of six sigma approach for increasing quality formal men's jackets in the garment industry," *J. Sist. Manaj. Ind.*, vol. 6, no. 1, pp. 33-44, Jun. 2022, doi: 10.30656/jsmi.v6i1.4359.
- [4] C. Ellegaard, U. Normann, and N. Lidegaard, "Intuitive global sourcing - A study of supplier selection decisions by apparel SMEs," *Int. J. Oper. Prod. Manag.*, vol. 42, no. 2, pp. 151-181, Jan. 2022, doi: 10.1108/IJOPM-03-2021-0205.
- [5] F. Hardt, M. Kotyrba, E. Volna, and R. Jarusek, "Innovative approach to preventive maintenance of production equipment based on a modified TPM methodology for Industry 4.0," *Appl. Sci.*, vol. 11, no. 15, p. 6953, Jul. 2021, doi: 10.3390/app11156953.
- [6] R. A. Joy, M. S. Hawlader, M. S. Rahman, M. R. Hossain, S. I. Shamim, and H. Mahmud, "Improving quality, productivity, and cost aspects of a sewing line of apparel industry using TQM approach," *Math. Probl. Eng.*, vol. 2024, no. 1, pp. 1-13, Feb. 2024, doi: 10.1155/2024/6697213.
- [7] S. Kirin and A. H. Šajatović, "Determination of working methods and normal times of technological sewing operation using MTM system," *Tekstilec*, vol. 63, no. 3, pp. 203-215, Sep. 2020, doi: 10.14502/Tekstilec2020.63.203-215.
- [8] M. Küçük, M. İşler, and M. Güner, "Optimizing the material-product transformation processes in the clothing manufacturing line," *Tekstil ve Konfeksiyon*, vol. 32, no. 2, pp. 135-145, Jun. 2022, doi: 10.32710/tekstilvekonfeksiyon.988251.
- [9] C. J. Moin, K. R. Hossain, and L. M. Baral, "Investigating root causes of sewing defects using TQM tools for quality improvement in the knit garment industry," *Text. Leather Rev.*, vol. 6, pp. 417-433, Sep. 2023, doi: 10.31881/TLR.2023.071.
- [10] National Institute of Statistics and Informatics (INEI), "Textile industry production statistics," INEI, Lima, Peru, 2024. [Online]. Available: https://www.inei.gob.pe/media/principales_indicadores/04-informe-tecnico-produccion-febrero-2024.pdf
- [11] Risteski S. and V. Srebrenkoska, "Textile waste from confection industries and possibilities for its recycling" *Tekstilna Industrija ., Shtip, Macedonia*, 2020, vol. 68, no. 4, pp. 77-82. doi: 10.5937/tekstind2004077R
- [12] M.-L. Tseng, T.-D. Bui, M. K. Lim, M. Fujii, and U. Mishra, "Assessing data-driven sustainable supply chain management indicators for the textile industry under industrial disruption and ambidexterity," *Int. J. Prod. Econ.*, vol. 245, p. 108401, Mar. 2022. doi: 10.1016/j.ijpe.2021.108401.

BIOGRAPHICAL NOTES

SEBASTIAN PEDRO CABALLERO-TRUJILLO

Sebastian Pedro Caballero-Trujillo holds a Bachelor's degree in Industrial Engineering from Universidad de Lima, Peru. He currently works as a Business Specialist at Banco de Crédito del Perú. He has experience as an intern in information management and in the Payment Solutions Tribe. His main research interests are risk management, collections, and payment solutions.

RENZO JEAN PIERRE MESTANZA-AMES

Renzo Jean Pierre Mestanza-Ames holds a Bachelor's degree in Industrial Engineering from Universidad de Lima, Peru. He is currently a professional intern in processes at Universidad de Lima. He has experience in operations, logistics, project management, productivity improvement, and health, safety, and environment. His main research interests are lean manufacturing and logistics.

GINO VIACAVA-CAMPOS

Gino Viacava-Campos holds a Master's degree in Operations and Logistics from Universidad Peruana de Ciencias Aplicadas, Peru, and a degree in Industrial Engineering from Universidad de Lima, Peru. He is currently a professor in the Industrial Engineering Program at Universidad de Lima. He has experience in industrial and service companies, focusing on productivity improvement, business model development, and compensation system structuring. He has worked in human resources, operations, and logistics areas of a transnational company, both locally and overseas. As a consultant, he has experience in the construction, manufacturing, services, mining, commercial, finance, and education sectors. He has co-authored papers including "A Production Process Efficiency Improvement Model at a MSME Peruvian Metalworking Company," published in the Proceedings of the 2022 IEEE International Conference on Industrial Engineering and Engineering Management (IEEM). His main research interests are lean manufacturing, master production schedules, logistics, and compensation systems for small and medium-sized enterprises.

JORGE ANTONIO CORZO-CHAVEZ

Jorge Antonio Corzo-Chavez holds a Master's degree in Business Administration from Universidad ESAN, Peru; a Master's degree in Marketing Science from ESIC Business & Marketing School, Spain; and a degree in Industrial Engineering from Universidad de Lima, Peru. He is currently a professor in the Industrial Engineering Program at Universidad de Lima and Chief Executive Officer at Conquista Lab. He has advised industrial and service companies on productivity improvement and business model development, and has worked in entrepreneurship, innovation, and commercial roles in the construction, mining,

services, and education sectors. He has co-authored papers including “Improvement of Productivity by Applying 5S, Work Standardization, Ergonomic Analysis and Poka Yoke in a Metalworking Company,” published in the Proceedings of the 23rd LACCEI International Multi-Conference for Engineering, Education, and Technology; “Production Model Based on Lean Manufacturing and Systematic Layout Planning to Reduce Waste in a Company in the Poultry

Sector: A Case Study,” published in the International Journal of Environmental Pollution and Remediation, volume 12; and “Model for Reducing Mean Absolute Percentage Error through Smoothing and Time Series Forecasting in a Tourism SME: A Case Study,” published in the Journal of Machine Intelligence and Data Science, volume 5. His main research interests are lean manufacturing, logistics, and machine learning for enterprises.

Operations Management Model to Improve Compliance with the Fan Production Plan through Process Standardization in the Metalworking Sector

Paola G. Pérez Cadillo¹ , Eliane T. Rivera Odar² , Carlos A. Lizarraga Portugal³ ,

Javier M. Castillo Tejada⁴ 

¹20203402@aloe.ulima.edu.pe, ²20201785@aloe.ulima.edu.pe, ³clizarra@ulima.edu.pe, ⁴javcasti@ulima.edu.pe

¹²³⁴Carrera de Ingeniería Industrial, Universidad de Lima, Perú

Received: July 20, 2025 / Accepted: September 17, 2025 / Published: 5 June, 2026

doi: <https://doi.org/10.26439/ciii2025.8646>

ABSTRACT—The metal-mechanic sector plays an important role for the Peruvian economy, representing approximately 1% of total GDP and 6% of manufacturing GDP. It is particularly relevant for its strategic role in providing essential components and services for sectors such as mining, construction, and agribusiness. The problem that motivates this study focuses on the need to reduce the waste of resources in metalworking companies where operational performance is affected, and in this sense, the research was carried out in a factory producing fans with the objective of developing an operations management model to improve compliance with the production plan. An empirical study was conducted using Lean Manufacturing techniques—specifically 5S, Standardized Work, and Single-Minute Exchange of Dies (SMED)—to develop a model that was functionally validated through a pilot test and process simulation. The results showed that production plan compliance reached 60.7%, non-productive time was reduced by 92.8%, cycle time decreased by 3.46%, and setup time was reduced by 25.2%. The contribution of this research demonstrates that integrating the applied engineering techniques results in a robust and effective combination for improving industrial processes.

Index Terms—5S, fan manufacturing, metalworking industry, SMED, standardization.

I. INTRODUCTION

This research addresses the problem of low production plan compliance in a Peruvian metalworking company dedicated to the manufacture of axial fans. The importance of this study lies in the strategic role of the metal-mechanic industry in the Peruvian economy, as it accounts for approximately 1% of the country's total Gross Domestic

Product (GDP) and 6% of manufacturing GDP, with an estimated annual turnover of 13 billion soles [1]. Beyond its economic contribution, the sector plays a strategic role by supplying components, metal structures, machinery, and specialized technical services that enable the operation and development of key industries such as mining, construction, agribusiness, and manufacturing in general. In this context, it was identified that the company under study has a production plan compliance rate of only 23.3%, which is significantly lower than the 70% achieved by leading plants in the sector [2]. This results in an annual economic impact of 573,804 soles—equivalent to 23% of the company's revenue— and highlights the need for a solution model aimed at addressing this type of issue.

The implementation of Lean Manufacturing techniques has shown significant benefits in industrial processes, particularly in enhancing efficiency within the metalworking sector, as underscored by various authors. In [3], issues such as high levels of non-productive time, disorder in the work area, lack of standardization in tool changes, and inefficient physical layout were identified. To address these issues, methodologies such as Sort, Set in order, Shine, Standardize, and Sustain (5S), Single-Minute Exchange of Dies (SMED), and Systematic Layout Planning (SLP) were applied, achieving a 6.79% reduction in lead time. Similarly, another study in the same sector found that low productivity resulted from workspace disorganization, the absence of standard times, and a lack of visual control. To mitigate these issues, tools such as 5S, Andon, and standard time were implemented, achieving an increase in productivity from 0.26 to 0.33 tons per sol over a five-month period [4].

In this context, the relevance of this study lies in its practical and applicable nature, as it proposes a model that not only enhances operational efficiency and reduces waste but also lays the foundation for a culture of continuous improvement within the sector, generating value and

contributing knowledge at both the business and industrial levels.

Based on the analysis conducted, the general objective of this research is to develop an operations management model that improves the production plan compliance in a metalworking factory through the application of Lean Manufacturing techniques. The specific objectives are to reduce material search times in the painting area, decrease variability in welding tasks, and optimize setup times in laser cutting and pressing machines. The scope of the research includes the improvement of operational processes in the painting, welding, cutting, and pressing areas in the production of axial fans. These areas were selected as the exclusive focus of intervention because they concentrate the main problems identified in the initial diagnosis, such as unnecessary delays, lack of standardization, and excessive setup times. The study followed a structured approach comprising an introduction and background review to define the objectives, a description of the methodology and tools, a presentation of the results with a before-and-after comparison, and a discussion contrasting the findings with the literature.

II. LITERATURE REVIEW

Various relevant academic sources published in recent years were analyzed and retrieved from databases such as SciELO, ScienceDirect, Dialnet, and Google Scholar.

A. 5S Methodology

According to a study conducted in a plant dedicated to the production of aqueous adhesives, significant improvements in productivity were achieved. Initially, major issues related to workplace disorder, the accumulation of unnecessary materials, and a lack of process standardization were identified. The initial diagnosis revealed a low 5S compliance score, averaging 2.8 points, which motivated the implementation of improvement strategies. These actions included removing non-essential materials, assigning specific locations for tools, introducing regular cleaning routines, designing standardized procedures, and training personnel to promote effective organizational practices. As a result, the 5S compliance score increased to an average of 4.03 points, leading to optimized time and space usage and an increase in average productivity from 4.37 kg/labor hour in 2019 to 5.58 kg/labor hour in 2020 [5].

B. Standardization

In an agricultural machinery manufacturing plant, waste and defective products were reduced through the implementation of standardization across six stages: current-state design, data collection, takt time calculation, preparation of the Operator Balance Chart (OBC), future-state design, and development of a Work Standard Sheet for each operator. The results showed time savings of 49.5 min

per day and approximately 18 h per month, and a significant reduction in the variation of returned boxes, with the coefficient of variation for “Bin A” boxes decreasing from 31.44% to 7.4% [6].

C. SMED

The implementation of this technique in a vacuum cleaner manufacturing company led to a significant reduction in model changeover times on the injection line, decreasing from 459 to 189 min, which represents an improvement of over 58% and a 68% achievement of the expected results [7]. Similarly, in a plastic products manufacturing company, the application of this technique reduced mould changeover time from 1 h and 23 min to approximately 49 min, representing a 36.79% improvement [8]. As a result, operational efficiency improved, failures related to the lack of procedures were reduced, and process stability was enhanced.

III. PROPOSED SOLUTION MODEL

A. Background

In the metalworking sector, small and medium-sized companies that manufacture equipment such as axial fans face important challenges related to their production processes efficiency. One of the main issues is the limited ability to meet established delivery deadlines, which directly affects customer satisfaction and business profitability. The average on-time delivery rate in this sector is only 70% [2], indicating shortcomings in operational management and in the effective use of available plant time. This situation highlights the need to implement improvements aimed at optimizing resource availability and reducing non-productive time.

Table I presents a matrix that links the identified root causes with the selected Lean Manufacturing techniques, including the main authors and the years in which their studies were carried out.

B. Model Components

The following solution model was developed, by integrating the data obtained during the diagnostic phase and linking the proposed actions for each selected technique, as shown in Fig. 1, to provide a structured and comprehensive view of the improvement proposal across its different phases and components.

Phase 1 - Diagnosis: This phase of the study corresponds to a quantitative, applied, and empirical research design, as it is based on the collection of real data and their analysis to identify opportunities for process improvement. Compliance with the production plan is identified as the dependent variable and cycle times, model changeover times, work area organization, and variability in task

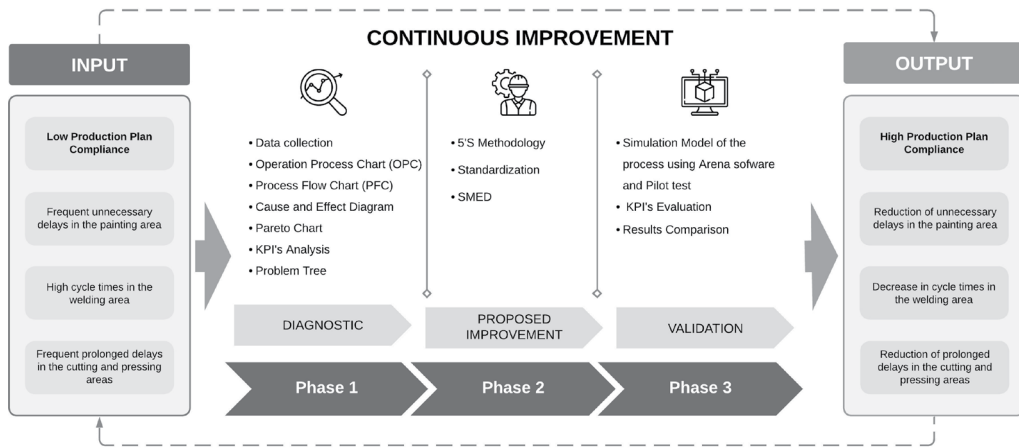

Fig. 1. Proposed solution model for an axial fan manufacturing company.

execution are identified as the independent variables. The unit of analysis is an axial fan.

The sampling strategy used was non-probabilistic convenience sampling, with data collected through direct observations in the plant.

Accordingly, instruments such as the Outline Process Chart (OPC) and the Process Flow Chart (PFC) were used for data collection and analysis, enabling the mapping of the current sequence of operations and the identification of non-value-adding activities. Analytical tools such as the Cause-and-Effect Diagram and the Pareto Chart were also applied to identify and prioritize the root causes of the problems. In addition, key performance indicators (production plan compliance, productivity, cycle time, and model changeover time) were analyzed, and a problem tree was developed to visualize cause-effect relationships (Fig. 2).

Phase 2 - Implementation of the Integrated System: The implementation of the 5S in the painting area is done through several steps. It begins with the elimination of unnecessary materials, followed by the organization of the workspace through the classification and labeling of containers and tools. Subsequently, specific locations are assigned to facilitate accessibility and maintain order. Thorough cleaning activities are then performed, and organization is standardized through the consistent use of visual controls. Finally, discipline is promoted among personnel through training, ensuring that the improvements are sustained on a continuous and long-term basis. As a result, workspace utilization is optimized, unnecessary movements are reduced, and overall operational efficiency is improved.

In the standardization stage, data are collected on the available production time and customer demand. These data are used to calculate the Takt time for the activities. Subsequently, the OBC is developed, which is a Lean Manufacturing tool used to visualize and improve

TABLE I
MATRIX LINKING ROOT CAUSES AND ANALYZED ARTICLES

Authors	Causes		
	<i>Long times due to disorder and visible waste</i>	<i>High task variability due to lack of standardized sequence</i>	<i>Long setup times due to manual calibrations without external preparation</i>
[2], [5]	5S		
[3], [9], [11]	5S		SMED
[4], [10]	5S	Standardization	
[6]		Standardization	
[7]			SMED
[8]	5S	Standardization	SMED
[12]		Standardization	SMED
Proposal	5S	Standardization	SMED

workload balance among operators on a production line. This diagram shows the time each operator dedicates to their assigned tasks, facilitating the identification of workload imbalances. For its analysis, it is necessary to measure the execution times of each workload and to redistribute tasks in order to achieve a better balance. The final step consists of developing a Work Standard Sheet for each operator, which includes specific activities, assigned times and sequence of operations.

SMED implementation starts with the identification of all operations related to the production cycle changeover, differentiating between internal activities, which are performed while the machine is stopped, and external activities, which can be performed while the machine is running.

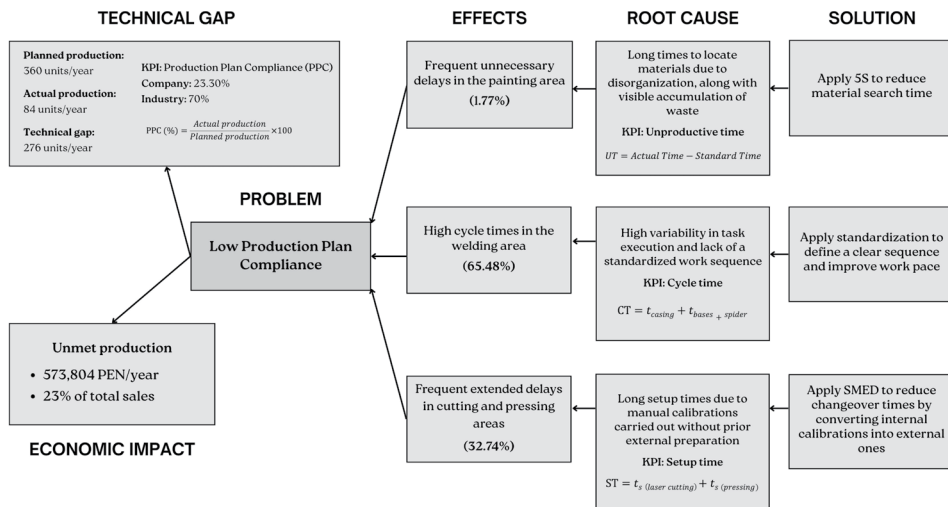

Fig. 2. Identification of problems, root causes, and solutions in axial fan production.

These activities are then classified to determine which can be carried out in parallel with the production process. Based on this classification, as many internal tasks as possible are converted into external ones in order to reduce downtime by preparing the tools and materials required for the next production cycle in advance.

Finally, the machine settings are optimized by eliminating non-value-adding activities and simplifying those that are necessary, in order to improve the efficiency of the setup process.

Phase 3 - Validation: The improvement proposal made it possible to identify and validate optimization opportunities at different stages of production. Validation is carried out through a pilot test of the 5S methodology, together with a simulation model also for the Standardization and SMED tools. As a result, a more orderly, balanced, and production-aligned operational scenario was designed. These improvements enhance operational efficiency and could be replicated in other areas of the shop floor, provided they are properly adapted to the specific process conditions.

C. Model Indicators

Indicators are proposed to measure production performance in terms of efficiency, time utilization, and responsiveness to demand. The formulas used, as well as the interpretation of their variables, are presented below:

- Compliance with the production program (CPP): *Actual production* corresponds to the volume effectively completed, while *planned production* refers to the assigned target; the result is multiplied by 100 to express it as a percentage.

$$CPP = \frac{\text{Actual production}}{\text{Planned production}} \times 100 \quad (1)$$

- Unproductive time: *Actual time* corresponds to the total observed duration, including delays, while *standard time* refers to the reference established by methods engineering; the difference represents the portion of the shift that does not generate value and can be reduced through the application of 5S.

$$UT = \text{Actual time} - \text{Standard time} \quad (2)$$

- Cycle time: Each t_s represents the manufacturing time of the part in the hull, bases and spider operations. As long as this sum exceeds the *Takt time*, the line will not meet the demand, making it essential to standardize work paths and reduce variability.

$$CT = t_{casing} + t_{bases + spider} \quad (3)$$

- Setup time: Each represents the setup time of the cutting and pressing areas, measured from machine stoppage to the production of the first conforming part after setup.

$$TS = t_s(\text{laser cutting}) + t_s(\text{pressing}) \quad (4)$$

IV. RESULTS

A problem tree was developed to break down the main problem into its causes and root causes. This analysis tool provides a clear and detailed understanding of the factors involved, facilitating the identification of specific corrective actions (Fig. 2). To complement this diagnosis, the OPC was used, which translates the identified problems into the production flow and enabling the visualization

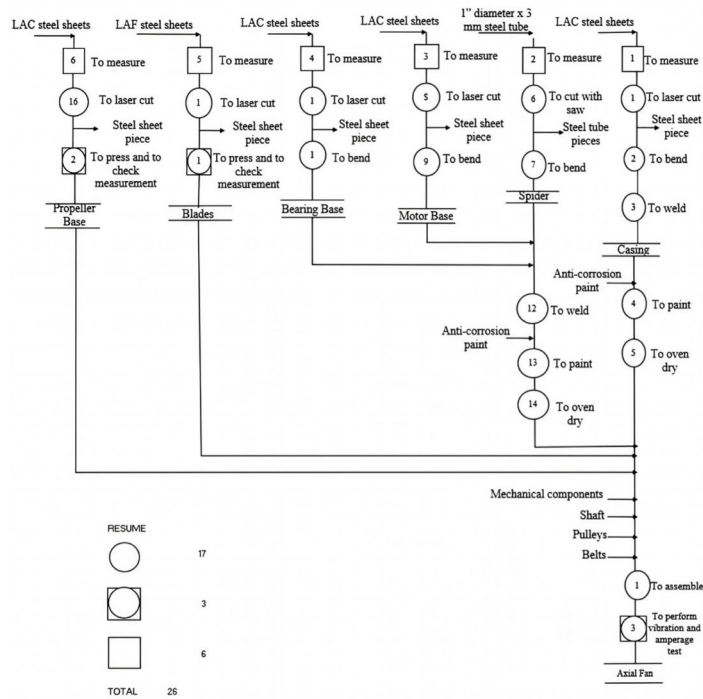

Fig. 3. OPC for the axial fan production process.

of the specific stages where they occur (Fig. 3). Its development enabled the identification of the points at which the different product components are incorporated, providing an overall view of the manufacturing and assembly process of axial fans. Likewise, it proved useful for understanding the process structure and for visually documenting the activities required for the development of the simulation model in Arena, as it provides the logical and detailed sequence of operations needed to construct the system flow.

To validate the effectiveness of the proposed improvements, two scenarios were developed in Arena software: one representing the current situation of the production process and the other one reflecting the system with the integrated improvements.

A. Modeling of the Current Situation

A base model representing the current situation was constructed and simulated using the Arena software. This model was built using data collected directly from the plant through on-site observations, interviews with operating personnel, and time measurements. The collected data were statistically analyzed to ensure their reliability and accuracy for use in the simulation.

The AS-IS model enabled the visualization of the actual behavior of the production flow, allowing the identification of constraints, delays, and sources of inefficiency. Among the main findings, long setup times were detected in the cutting and pressing stations, resulting in availability losses

that affect process continuity. At the welding station, high variability in execution times was observed, leading to an unbalanced line and making it the most time-consuming operation. Likewise, in the painting area, disorder in the handling of materials and tools was identified, causing unnecessary movements and rework.

The current conditions of the tools that would later be intervened were incorporated into the simulation model. Setup times were represented as currently recorded, reflecting the lack of separation between internal and external activities during changeover processes. At the welding station, tasks without standardized procedures were simulated. Finally, the current behavior of the painting area was included, where no organized or structured system exists for the storage and use of materials.

B. Design of the Improved Model

The improved model incorporates three key tools: 5S, Standardization, and SMED. The 5S methodology was physically implemented in the painting area, following each of its stages. This intervention produced visible improvements in organization, tool accessibility, and reduction of non-value-adding time, which were replicated in the simulation. Standardization was validated through simulation in Arena at the welding station, where improvements in task sequence and distribution were proposed. These actions reduced operational variability and balanced work times with respect to customer demand, enhancing consistency

in task execution. Finally, SMED was simulated on the machines, identifying activities that could be performed outside of machine downtime.

The integration of these tools enabled the validation, in a virtual environment, of the positive impact these improvements would have on the production system. The resulting model represents a more organized process, with reduced variability and greater capacity to meet production requirements.

After the implementation of 5S, a comparative evaluation of the initial and final states of the system was conducted through inspections, with the participation of operators. The scores were grouped by category and compared against a maximum of 25 points for each “S,” representing optimal conditions. In the initial condition, the results showed a poor overall performance, reaching only 27% of the total possible score. Shine achieved a score of 44%, while the pillars of Standardize (16%), Set in order (24%), Sustain (24%), and Sort (28%) exhibited worryingly low levels. These results indicate a disorganized plant, with few standardized practices and no well-established culture of sorting or maintaining order.

Table II lists significant improvements across all pillars, reaching 69.6% of the total score. Remarkable progress was observed in Sustain (84%), Shine (80%), and Sort (68%), reflecting increased staff awareness, improved operational practices, and a more structured work environment.

These results are graphically presented in a radial diagram designed to comparatively visualize performance before and after the intervention (Fig. 4). The diagram clearly shows the growth in each dimension evaluated, validating the effectiveness of the implementation and highlighting the positive impact of 5S on the plant’s organizational culture.

The results obtained validate the fulfillment of the general objective of the study: to develop an operations management model to improve compliance with the fan production plan through standardization in the metalworking sector. The implementation of the model increased the production plan compliance from 23.3% to 60.7%, demonstrating that the standardization applied in the different areas of the process had a direct and positive impact on the company’s ability to meet its production goals.

In relation to the specific objectives, the results were also consistent. First, the application of the 5S methodology in the painting area led to a significant reduction in unproductive time, from 82.1 min to just 5.89 min. This improvement was achieved by eliminating time wasted searching for materials and tools, and by optimizing the work environment. Secondly, the standardization of a work sequence in the welding area reduced variability in task execution, which was reflected in a decrease in the total cycle time, which went from 3,180 to 3,070 min. This enhanced the overall efficiency of the production process and contributed to increased compliance with the production plan.

TABLE II
5S INITIAL AND FINAL INSPECTION RESULTS

Concepts	AS-IS	TO-BE	Maximum	AS-IS (%)	TO-BE (%)
Sort	7	17	25	28	68
Set in order	6	16	25	24	64
Shine	11	20	25	44	80
Standardize	4	13	25	16	52
Sustain	6	21	25	24	84
Total	34	87	125	27	69.6

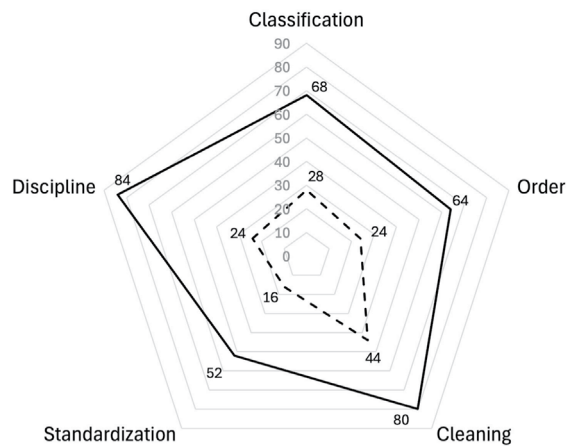

Fig. 4. Comparative radial diagram of the initial and final state of 5S.

TABLE III
COMPARISON OF RESULTS

Indicators	Units	AS-IS	TO-BE
Production program compliance	Percentage	23.3	60.7
Non-productive time	Minutes	82.1	5.89
Cycle time	Minutes	3,180	3,070
Setup time	Minutes	151	113

Finally, Table III demonstrates that with the implementation of the SMED methodology on the laser cutting and pressing machines, the setup time was reduced from 151 to 113 min, which favored greater machine availability and faster preparation between production batches. Overall, these results demonstrate that the proposed model is effective in improving operational efficiency and ensuring compliance with the production plan.

V. DISCUSSION

To enrich the analysis, a comparison of the results obtained and those reported in other studies is presented. In our case study, the 5S methodology reduced nonproductive times from 82.1 to 5.89 min, which represents an improvement of 92.8%. This result contrasts with the study conducted in the plastic products manufacturing plant, where the technique was applied in the injection and painting areas, achieving a 65% reduction in the time spent searching for tools and materials [8]. Similarly, in a metalworking company dedicated to the production of light metallic structures, the methodology was implemented in the lathe and milling stations, as well as in the warehouse, materials yard, and dispatch area, achieving a 75.2% of idle times related to the location of inputs and equipment [9]. In both cases, the intervention covered several areas of the process, which required more resources and time. In contrast, this study focused only on the painting area, which enabled a higher percentage of improvement.

Regarding Standardization, its application reduced the total cycle time from 454.29 to 428.57 min per unit, which represents an improvement of 3.46%. Although the percentage improvement is not high, this result contributes positively to the overall production performance. This is consistent with a study reporting the implementation of standardized work in an H-beam factory, showing that the cycle time was reduced from 294.99 to 286.92 min per unit produced, equivalent to an improvement of 2.74%. When comparing the results, it can be observed that the improvement achieved in this study is slightly higher, which reinforces the effectiveness of the applied technique. In both cases, despite being processes with long cycles, the improvements in the welding area are significant, as this operation represents the main bottleneck of the system [10].

In relation to SMED, the setup time reduced from 151 to 113 min, representing a significant improvement of 25.2%. This result is comparable to that reported in a study on a metalworking factory, where a reduction of 30.11% was achieved. Although both studies applied the separation of internal and external activities, the difference lies in the fact that this study complemented this strategy with complete standardization of procedures through clear instructions, defined sequences, and checklists, which explains its higher percentage of improvement [11]. In contrast, an auto parts assembly line achieved a greater reduction of 36%, mainly due to an effective reorganization of the workspace [12], an aspect not addressed in the present study, which also contributes to the difference in the results.

VI. CONCLUSIONS

The results obtained show significant progress in line with the objectives set. The implementation of the 5S methodology in the painting area reduced downtime by 92.8% by optimizing the organization and location of materials;

the standardization of welding tasks decreased cycle time by 3.46%, promoting a more continuous workflow; and the application of the SMED methodology in cutting and pressing reduced setup times by 25.2%, by converting internal activities into external ones and improving machine availability. These improvements, integrated into an operations management model, increased production plan compliance to 60.7%, thereby reducing the gap with the 70% recorded in the industry's leading plants and demonstrating the potential of Lean tools to close performance gaps and improve productivity.

It is recommended to implement the 5S methodology throughout the plant, as its comprehensive application would optimize overall organization, reduce nonproductive time in other areas, increase safety, and reinforce operational discipline across all processes. This would help consolidate a culture of order and cleanliness that promotes a more efficient work environment prepared for future Lean improvements. It is also advisable to gradually expand the scope of SMED and standardization to other areas, accompanying this process with training and monitoring plans to ensure its sustainability, and use specialized software to simulate changes prior to their physical implementation. Finally, future studies could take this Lean Manufacturing model as a basis for validating its effectiveness in different production contexts, optimizing processes in specific environments, and generating applied technical knowledge that strengthens the competitiveness of the metallurgical sector and its strategic role in key industries such as mining, construction, agribusiness, and manufacturing.

REFERENCES

- [1] T. Jonathan, "Sector metalmecánico multiplica el empleo por cuatro y hoy depende de la inversión minera [Metalworking sector multiplies employment fourfold and now relies on mining investment]," *Dipromin.com*, Sep. 4, 2022. [Online]. Available: <https://bit.ly/4nQopqO>
- [2] J. I. Illaganqui Florida and Y. I. Galvez Martinez, "Implementación de las herramientas 5S y TPM para aumentar el índice de entrega de pedidos a tiempo en una empresa metalmecánica [Implementation of 5S and TPM tools to increase the on-time delivery rate in a metalworking company]," *Professional degree thesis*, Academic Program of Industrial Engineering, Universidad Peruana de Ciencias Aplicadas, Lima, Peru, 2023. [Online]. Available: <http://hdl.handle.net/10757/671591>
- [3] M. A. Arbieto Martos and J. A. Vásquez Meza, "Mejora de los procesos productivos usando herramientas de Lean Manufacturing en una MYPE de carpintería metálica para disminuir la tasa de entregas tardías [Improvement of production processes using Lean

- Manufacturing tools in a metal carpentry SME to reduce the late delivery rate],” B.S. thesis, Academic Program of Industrial Engineering, Universidad Peruana de Ciencias Aplicadas, Lima, Peru, 2020. [Online]. Available: <http://hdl.handle.net/10757/654448>
- [4] J. A. Bravo Fernandez, “Aplicación de herramientas Lean Manufacturing (5S, Andon y Tiempo Estándar) para el aumento de la productividad en el área de producción de una empresa metalmeccánica [Application of Lean Manufacturing tools (5S, Andon, and Standard Time) to increase productivity in the production area of a metalworking company],” *Ind. Data*, vol. 26, no. 1, pp. 217–245, Jul. 2023, doi: <https://doi.org/10.15381/idata.v26i1.24580>
- [5] E. L. Vargas Crisóstomo and J. W. Camero Jiménez, “Aplicación del Lean Manufacturing (5S y Kaizen) para el incremento de la productividad en el área de producción de adhesivos acuosos de una empresa manufacturera [Application of Lean Manufacturing (5S and Kaizen) to increase productivity in the aqueous adhesive production area of a manufacturing company],” *Ind. Data*, vol. 24, no. 2, pp. 249–271, Dec. 2021, doi: <https://doi.org/10.15381/idata.v24i2.19485>
- [6] D. M. C. dos Santos, B. K. dos Santos, and C. G. dos Santos, “Implementation of a standard work routine using Lean Manufacturing tools: A case study,” *Gest. Prod.*, vol. 28, no. 1, e4823, Feb. 2021, doi: <https://doi.org/10.1590/0104-530x4823-20>
- [7] M. A. Morales Rodriguez, G. Cervantes Zubirías, J. Y. Wong Gallegos, and R. Martínez Mendoza, “Reducción de los tiempos de cambio de modelo en los productos fabricados en una empresa manufacturera de aspiradoras [Reduction of model changeover times in products manufactured in a vacuum cleaner manufacturing company],” *Multidiscip. Ing.*, vol. 9, no. 13, pp. 12–22, Dec. 2023, doi: <https://doi.org/10.29105/md.v9i13.260>
- [8] P. Ribeiro, J. C. Sá, L. P. Ferreira, F. J. G. Silva, M. T. Pereira, and G. Santos, “The impact of the application of lean tools for process improvement in a plastic company: A case study,” *Procedia Manuf.*, vol. 38, pp. 765–775, Jan. 2019, doi: <https://doi.org/10.1016/j.promfg.2020.01.104>
- [9] C. M. Valenzuela Huaraca and J. B. Chipana Ayala, “Propuesta de mejora del proceso de producción para reducir los tiempos improductivos basada en la implementación de SLP, 5s y SMED en el sector metalmeccánica [Production process improvement proposal to reduce unproductive time based on the implementation of SLP, 5S, and SMED in the metalworking sector],” *Professional degree thesis*, Academic Program of Industrial Engineering, Universidad Peruana de Ciencias Aplicadas, Lima, Peru, 2023. [Online]. Available: <http://hdl.handle.net/10757/671840>
- [10] V. Barrenechea Chamorro, “Propuesta de mejora de la eficiencia en la fabricación de vigas en una empresa MYPE del sector metalmeccánico en el Perú, utilizando herramientas de Lean Manufacturing y estandarización de trabajo [Proposal to improve efficiency in beam manufacturing in an SME of the metalworking sector in Peru using Lean Manufacturing tools and work standardization],” *Professional degree thesis*, Academic Program of Industrial Engineering, Universidad Peruana de Ciencias Aplicadas, Lima, Peru, 2022. [Online]. Available: <http://hdl.handle.net/10757/660864>
- [11] D. I. Ramirez-Lozano, J. E. Avilés-Solano, and M. Collao Diaz, “Process optimization in metalworking SMEs by implementing Lean Manufacturing tools: An integrated approach to improving operational efficiency,” in *Proc. 5th Asia Pacific Conf. Ind. Eng. Oper. Manag. (AP05)*, Tokyo, Japan, Sep. 10–12, 2024, doi: <https://doi.org/10.46254/AP05.20240087>
- [12] C. Oliveira and T. M. Lima, “Setup time reduction of an automotive parts assembly line using lean tools and quality tools,” *Eng.*, vol. 4, no. 3, pp. 2352–2362, Sep. 2023, doi: <https://doi.org/10.3390/eng4030134>

BIOGRAPHICAL NOTES

PAOLA GUADALUPE PÉREZ CADILLO

Paola Guadalupe Pérez Cadillo holds a Bachelor's degree in Industrial Engineering from Universidad de Lima, with a specialization in Business Engineering. She also earned a certificate in Financial Analysis and Management Strategies from the Oxford International Study Abroad Programme at St Antony's College, University of Oxford. She previously worked as a Logistics Intern at Artesco S.A., where she optimized dispatch flows by designing data-driven tracking architectures, ensuring operational integrity and process traceability. Her professional objective is to integrate Lean Manufacturing methodologies and systems simulation for industrial optimization, applying these capabilities to the energy transition and sustainable systems modeling.

ELIANE TERESA RIVERA ODAR

Eliane Teresa Rivera Odar holds a Bachelor's degree in Industrial Engineering from Universidad de Lima and ranked in the top 30% of her class. She currently works as a Professional Intern in the Sales Department, where she applies her academic background to commercial support, sales data monitoring, and team coordination to meet departmental objectives. Her research interests focus on operations management aimed at production plan fulfillment

and its impact on organizational commercial performance. Professionally, she is interested in the commercial sector, market analysis, customer experience, and the strategic use of data to support business management.

CARLOS AUGUSTO LIZARRAGA PORTUGAL





Carlos Augusto Lizarraga Portugal holds a Doctorate in Education from Universidad de San Martín de Porres, a Master's degree in Administration from ESAN, and a degree in Industrial Engineering from Universidad de Lima, where he graduated cum laude. He also completed postgraduate studies in auditing and implementation of Integrated Management Systems, including ISO 9001 Quality, ISO 14001 Environment, OHSAS 18001 Occupational Health and Safety, and Social Responsibility. He is a professor in the Industrial Engineering Program at Universidad de Lima, where he teaches courses on comprehensive safety, maintenance management, business diagnosis, and research projects. He is also a business consultant specializing in strategic planning, occupational health and safety management systems, logistics management, purchasing management, strategic inventory control, supply chain management, warehouse management, state purchasing

processes, costs, and asset management. He has experience in sectors such as clothing, plastics, industrial footwear, fishing, services, marketing, and training. He also works as a trainer and facilitator in seminars on strategic planning, business organization, production management, operations management, strategic inventory control, supply chain management, industrial safety, and comprehensive safety management, and serves as thesis advisor and jury member for the Industrial Engineering degree.

JAVIER MIGUEL CASTILLO TEJADA

Javier Miguel Castillo Tejada holds an MBA from UNIR México and a Bachelor of Science degree in Industrial Engineering from Pontificia Universidad Católica del Perú. He currently works as professor at Universidad de Lima. He has co-authored the papers "Quality Process to Improve Operating Results: A Study on Potato Production in Barranca, Peru" (CONIITI 2022); "Reduction of Non-Conforming Products through a Quality Management Model Using Lean Manufacturing Tools in the Wood Furniture Industry" (CONIITI 2022); and "Warehouse Management Model Based on Lean and SLP to Reduce Non-Compliance with Delivery Deadlines in a Peruvian Cocoa SME" (CONIITI 2022).

Proposal to Enhance Productivity by Applying Lean Manufacturing Tools in a Fish Canning Company

Flavia Espinoza-Montero¹ , Rodrigo R. Quintanilla-Chalan² , Jorge A. Corzo-Chavez³ ,
Gino Viacava-Campos⁴ 

¹ 20204379@aloe.ulima.edu.pe, ² 20201683@aloe.ulima.edu.pe, ³ jacorzo@ulima.edu.pe, ⁴ geviacav@ulima.edu.pe

¹²³⁴ Carrera de Ingeniería Industrial, Universidad de Lima, Perú.

Received: 19 July, 2025 / Accepted: 5 November, 2025 / Published: 5 June, 2026

<https://doi.org/10.26439/ciii2025.8647>

ABSTRACT—This project presents the design and partial implementation of a productivity improvement model based on Lean Manufacturing principles in a fish canning company. The approach involved a technical diagnosis and root cause analysis to identify key operational inefficiencies, primarily related to frequent equipment stoppages, prolonged changeover times, and a lack of process standardization. To address these issues, Total Productive Maintenance (TPM) and Single-Minute Exchange of Die (SMED) methodologies were applied, and their impact was assessed through simulation using Arena software. Results revealed significant productivity improvements. Labor productivity increased from 6 to 7 units/h, while annual defective output decreased from 372,370 to 86,310 cans. Changeover times were reduced from 23.8 to 8.1 min, and equipment failure rates declined from 13.67% to 4.59%. These improvements contributed to a higher level of Overall Equipment Effectiveness (OEE). Additionally, the project enhanced operator skills, increased process stability, and strengthened operational discipline. The study demonstrates that Lean Manufacturing tools can be successfully adapted to the realities of small-scale fish processing operations, offering a viable pathway to boost competitiveness, reduce waste, and meet the demands of increasingly rigorous markets.

Index Terms—Fish processing industry, industrial production, simulation, SMED, TPM.

I. INTRODUCTION

The fishing sector in Peru plays a crucial role in the national economy, leading global exports of fishmeal and fish oil, mainly derived from anchoveta. In 2024, canned fish exports reached approximately USD 95 million FOB, representing a 64.5% increase compared to the previous year. The

main destination markets were the United Kingdom, the United States, the Netherlands, Spain, Chile, and Germany. This growth was primarily driven by canned tuna products, which accounted for 87.5% of total export value, followed by anchoveta (8.3%), horse mackerel (1.9%), abalone (1.3%), and mackerel (0.9%) [1]. The sector generates significant employment and contributes to Gross Domestic Product (GDP); however, it faces critical challenges, including the El Niño and La Niña phenomena, which alter oceanographic conditions and reduce anchoveta populations, alongside historical overexploitation and illegal fishing. These issues have led the government to implement strict regulations, including catch quotas and closed seasons, to ensure sustainability. Despite informality and infrastructural limitations, artisanal fishing remains vital for food security and the livelihoods of coastal communities. Aquaculture is gaining importance through products such as trout and shrimp, diversifying exports, however this sub-sector still faces financing and technological barriers. Additionally, certifications such as the Marine Stewardship Council (MSC) are becoming increasingly relevant, enhancing competitiveness in international markets that demand sustainable products.

Within this context, the studied company is a medium-sized fish canning processor operating two 8-hour shifts with an installed capacity of 180 tons per shift. However, it currently operates below its potential. Key operational issues include obsolete machinery, frequent unplanned equipment breakdowns due to inadequate preventive maintenance, lack of work standardization, and bottlenecks in manual processes. These problems resulted in low productivity, which the company aims to increase. The benchmark analysis was conducted to a case study of improvements in a food company that applied the same lean manufacturing tools, such as SMED and TPM, achieving an 8.11% increase in productivity [2]. This situation significantly affects

profitability and competitiveness, as illustrated in Fig. 1. These baseline values, obtained from the company's internal production reports (2023), served as the main reference for defining the improvement objectives and identifying the root causes and corresponding Lean tools.

A systematic literature review was conducted following the PRISMA methodology. From an initial set of 543 publications, 40 studies met the inclusion criteria, focusing on Lean Manufacturing tools such as Total Productive Maintenance (TPM) and Single-Minute Exchange of Die (SMED). The reviewed studies demonstrated that TPM improves equipment availability and reduces failure rates, while SMED significantly decreases changeover times, leading to higher productivity and lower operational costs across various manufacturing sectors, including food processing. Notable findings include a 5% increase in Overall Equipment Effectiveness (OEE) through TPM implementation [3] and improvements in quality performance from 49.44% to 94.64% in metalworking industries using integrated Lean tools [4].

The general objective of this project is to design and partially implement a Lean Manufacturing-based management model to increase productivity in canned fish production. The specific objectives are to diagnose the main causes of production inefficiency through process and time analysis, conduct a systematic literature review on Lean Manufacturing applications in fish processing SMEs, propose improvement solutions based on TPM and SMED methodologies, and validate the proposed improvements simulation using Arena software.

This study addresses this gap by offering practical insights into the optimization of core operations in fish canning, a sector often overlooked in academic research. It contributes applicable knowledge that supports decision-making, strengthens operational performance, and fosters innovation in production systems under real industrial constraints, expanding the scope of engineering

solutions in environments where traditional approaches may not be feasible.

II. METHODOLOGY

The diagnosis of the production process allowed the identification of key inefficiencies related to equipment stoppages, extended setup times, and lack of process standardization. Based on these findings and supported by the review of previous studies, three Lean Manufacturing tools were selected as part of the improvement strategy. SMED methodology was applied to reduce changeover time in the sealer, a stage characterized by non-standardized activities and frequent delays. Prior evidence indicates that this tool can reduce setup times by more than 30%, contributing to increased equipment availability and production flow. TPM was used to address the high frequency of unplanned machine downtimes, especially in the autoclave area. This tool enhances operator involvement in basic maintenance tasks and aims to minimize failures by improving equipment reliability. To define the size of the study sample, it was assumed that the company records an average of 220 productivity-impacting events per month, including autoclave downtimes and sealer changeovers. A sample size calculation was performed, assuming a confidence level of 95% and a margin of error of 5%, yielding the minimum number of replications required:

$$n = \frac{220 \times (1.96)^2 \times (0.5) \times (0.5)}{(220 - 1) \times (0.05)^2 \times (1.96)^2 \times (0.5) \times (0.5)} \quad (1)$$

By solving the values into (1) yielded a minimum sample size of approximately 141 observations. The main variables analyzed in this study were production time, equipment availability, failure rate, and defect percentage. These indicators formed the basis for quantifying the impact of the proposed

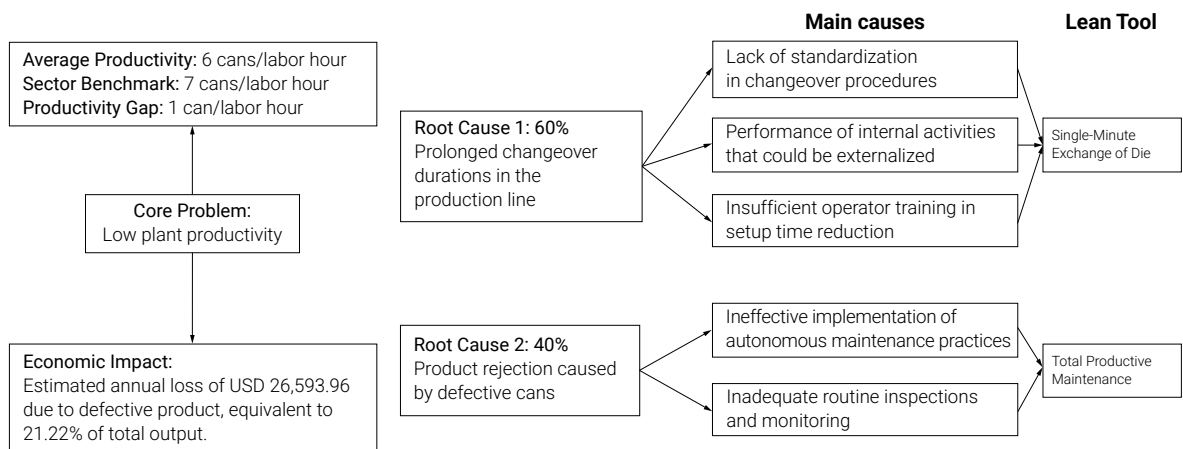

Fig. 1. Root cause analysis of low plant productivity and selection of Lean Manufacturing tools.

improvements, which were evaluated through simulation modeling using real production data from the plant.

A non-probabilistic convenience sampling method was used, as the study included all available critical occurrences during one month of normal plant operation [5]. The approach prioritized the rapid and efficient collection of real data on issues directly affecting plant efficiency. Only autoclave downtimes and sealer changeovers that impacted the regular production process were considered. To ensure consistency and alignment with the project objectives, specific inclusion and exclusion rules were defined. The inclusion criteria encompassed all documented autoclave downtimes and sealer changeovers during the selected month, provided that they were recorded in production reports or operational logs and occurred under normal operating conditions. Exclusion criteria applied to downtimes or changeovers resulting from scheduled or extraordinary maintenance, as well as events caused by external factors such as power outages or natural phenomena. Records without supporting documentation or containing incomplete data were excluded from the analysis.

Based on these tools, a structured improvement model was developed to guide the implementation strategy, as illustrated in Fig. 2.

A. Component 1: Minimize Format Changeover Time

The analysis of current format changeover times revealed high variability and the presence of unproductive periods caused by poorly organized internal activities. To address this issue, the SMED methodology was proposed to reduce these times and transition from a reactive approach to a standardized one. A detailed time study was conducted during changeovers in the sealing line, with each task chronometrically recorded. For example, seal replacement currently requires 4.5 min and gasket inspection 2 min, both performed while the machine is stopped. Under the SMED proposal, these activities were externalized, reducing internal setup time from 12.9 to 5.3 min. This task reclassification and redistribution were incorporated into the Arena simulation model to validate the expected improvements in equipment availability and production flow. Based on this analysis, standardized procedures and optimized task sequences were developed and implemented in the simulation. The estimated reduction in changeover time was used as an input parameter to project its impact on the overall production flow.

A flowchart illustrating these activities is shown in Fig. 3.

Table I presents the classification of the current setup activities performed on the sealing machine, distinguishing between internal and external tasks according to the SMED methodology. A total of ten activities were identified, five of which are currently carried out while the machine is stopped (internal), and five that can be or are already performed externally. This breakdown served as the basis

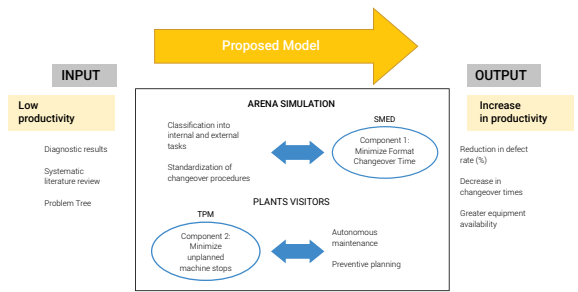

Fig. 2. Proposed model.

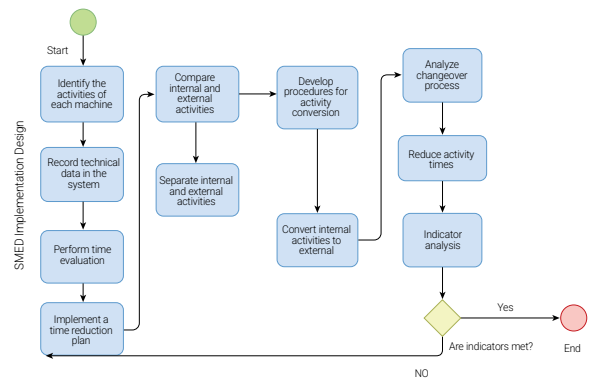

Fig. 3. SMED implementation design.

TABLE I
CLASSIFICATION OF SETUP ACTIVITIES IN THE SEALING MACHINE ACCORDING TO SMED METHODOLOGY

Activity	Current method		
	Time	Internal	External
Calibration verification	85 min	X	
Daily cleaning of sealing heads	65 s		X
Pressure adjustment	60 s	X	
Seal replacement	85 s	X	
Inspection of worn parts	60 s		X
Roller inspection	70 s		X
Sealing mechanism adjustment	90 s	X	
Inspection and lubrication of moving parts	80 s		X
General equipment cleaning	120 s		X
Gasket replacement	80 s	X	

for identifying improvement opportunities, particularly by proposing the externalization of tasks such as material preparation, cleaning, and preliminary inspections to reduce overall changeover time.

By applying the SMED methodology, setup activities were restructured to distinguish between internal and external tasks, aiming to minimize machine downtime. As presented in Table II, the proposed improvements resulted in the following optimized times: sealing head verification and cleaning (70 s), inspection of worn parts (55 s), adjustment of sealing mechanisms (90 s), general equipment cleaning (120 s), and gasket replacement (80 s).

These changes reduced the proportion of internal activities by transferring non-critical operations to external preparation and by standardizing procedures such as mechanism adjustment and gasket installation. Consequently, the overall setup process became more efficient, leading to increased equipment availability and a reduced productivity losses caused by extended changeover times.

B. Component 2: Minimize Unplanned Machine Stops

The second intervention component focuses on the implementation of basic TPM practices, targeting equipment with high failure frequency, specifically the sealer and the autoclave. The most frequent failures and their repair times were analyzed to prioritize the assets requiring intervention.

The plan specified concrete actions such as: (1) daily lubrication of sealing heads and inspection of worn parts, (2) weekly calibration of pressure sensors and inspection of hinges, and (3) monthly cleaning of filters and verification of control instruments. To strengthen operator involvement, visual control boards for abnormal conditions and a simplified system for recording minor incidents were introduced. These measures aimed to reduce recurrent stoppages in the autoclave and sealing machines, thereby increasing Mean Time Between Failures (MTBF) and reducing Mean Time to Repair (MTTR). Information regarding the expected improvements in equipment availability—specifically variations in MTBF and MTTR—was included as input parameters in the Arena simulation model to analyze their impact on overall productivity.

Table III presents the operational and maintenance records of the Autoclave, which shows a higher frequency of unplanned stoppages and unexpected failures compared to other equipment in the process. To improve clarity, failures were classified by type, frequency, average repair time (min), and estimated impact on equipment availability. This breakdown highlights recurring issues such as pressure calibration errors, sealing mechanism malfunctions, and wear in critical components, which justified prioritizing the autoclave in the TPM intervention plan. The proposed actions focused on preventive measures including filter cleaning, hinge lubrication, and regular inspection of control instruments. The observed variability in equipment availability and product quality underscores the need for structured maintenance routines to ensure process reliability and minimize downtime.

A detailed TPM model was constructed, as shown in Fig. 4, to identify key preventive maintenance activities for the sealing and autoclave machines. The model incorporated

TABLE II
PROPOSAL METHOD OF SETUP ACTIVITIES IN THE SEALING MACHINE ACCORDING TO SMED METHODOLOGY

Activity	Proposal method		
	Time	Internal	External
Sealing head verification and cleaning	70 s		X
Inspection of worn parts	55 s		X
Adjustment of sealing mechanisms	90 s	X	
General equipment cleaning	120 s		X
Gasket replacement	80 s	X	

TABLE III
OPERATIONAL AND MAINTENANCE RECORDS OF THE AUTOCLAVE MACHINE

Failure type	Frequency (occurrences/month)	Average repair time (min)	Availability impact (%)
Pressure calibration failure	12	35	4.5
Sealing mechanism malfunction	9	28	3.8
Gasket wear and replacement	7	22	2.7
Control instrument misalignment	5	40	3.2
Overheating due to filter clogging	4	30	2.1

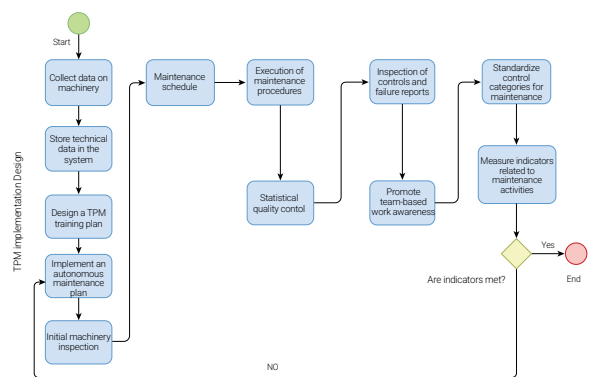

Fig. 4. TPM implementation design.

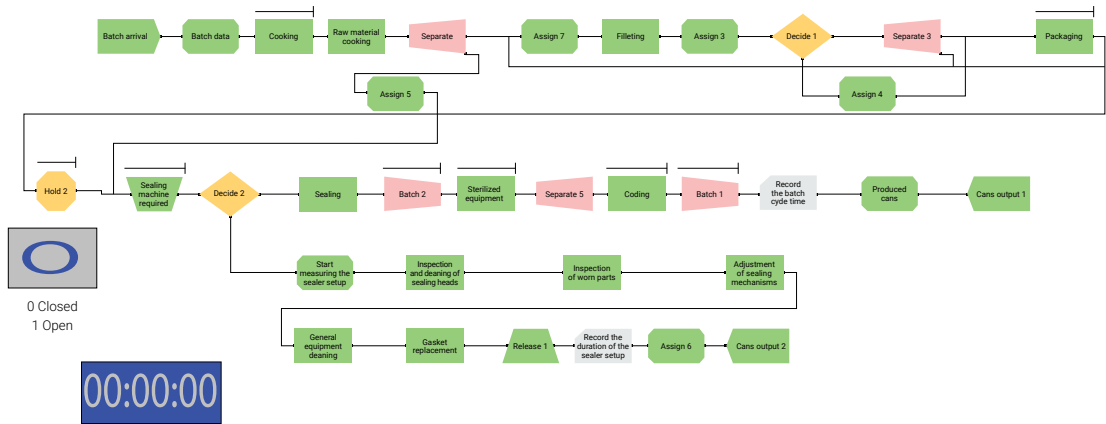

Fig. 5. Arena model.

the average duration of each intervention along critical decision points, enabling the simulation of their impact on operational continuity and overall process efficiency.

Table IV presents a comparative analysis of key operational performance indicators before and after the proposed improvements. The AS-IS column reflects the current performance of the plant, while the TO-BE scenario represents the expected outcomes after implementing the Lean Manufacturing strategies. The selected indicators—productivity, defect rate, and OEE—provide a clear overview of the potential impact on efficiency and quality.

The Arena simulation model shown in Fig. 6 was designed to replicate the actual production flow of the fish canning plant, with a particular focus on identifying while quantifying the impact of inefficiencies related to changeover times and unplanned equipment downtime. The process was mapped from the arrival of raw material batches through the main transformation stages—including cooking, filleting, sealing, sterilization, and packaging—incorporating key decision points, resource constraints, and batch processing logic.

Each block in the model represents a specific operation or activity using Arena’s standard modules, such as *Process*, *Assign*, *Decide*, and *Separate*. The sealing machine, which was central to the SMED intervention, was modeled with conditional logic to simulate equipment occupancy and the changeover routine. Additional logic flows were introduced to capture detailed maintenance procedures, such as cleaning, gasket replacement, and sealing mechanism adjustments, allowing for a realistic representation of the setup phase. Time data used in the model were obtained through direct measurement and field observation and were entered as input parameters to evaluate both the AS-IS and TO-BE scenarios.

To determine the appropriate number of simulation replications and ensure the statistical reliability of the output data, an initial run of 30 replications was executed.

TABLE IV
OPERATIONAL KPI ANALYSIS: AS-IS VS. TO-BE SCENARIO

Indicator	Formula	AS-IS	TO-BE
Productivity	$\frac{\text{Cans produced}}{\text{Total labor hours worked}}$	6	7
Defect rate	$\left(\frac{\text{Number of defective cans}}{\text{Total units produced}} \right) \times 100$	13%	4.3%
OEE	$\text{Availability} \times \text{Performance} \times \text{Quality}$	63.2%	68.2%

This resulted in an average production of 371,590, cans with a 95% confidence interval ranging from 369,961 to 373,219. The calculated half-width (h_0) of the interval was 1,628.8. Based on a desired error margin of 814.4 cans—equivalent to 2.2% of the sample mean—a statistical formula was applied to estimate the required number of replications. Consequently, it was determined that 120 replications were necessary to achieve the desired level of precision in the simulation results, thereby ensuring a high level of statistical confidence in the system performance analysis.

III. RESULTS

Once the Arena simulation was completed, outcomes were collected for the five defined performance indicators and compared against their respective target values. The key indicator under analysis was overall productivity, which initially measured 6 cans per labor hour. Following the proposed improvements, the simulation demonstrated a 17% increase, reaching 7 cans per labor hour, as shown in Fig. 5.

Regarding the setup time indicator, the process originally required 12.9 min, with a target reduction to 5 min. The simulation results closely approached this objective,

achieving a setup time of 5.3 min—representing a 59% decrease, as illustrated in Fig. 7.

Regarding the cycle time per batch indicator, the process initially recorded 28.5 min with a target reduction of 40%. The experimental results closely approached the expected value, as illustrated in Fig. 8, thereby achieving a reduced cycle time of 18.8 min—representing a 34% decrease.

For the defective cans indicator, the initial figure was 372,370 cans per year, with a target of 180,000. As shown in Fig. 9, the experimentation reduced this number to 187,895 cans annually—a 50% decrease. Although the target was not fully achieved, the outcome still reflects a substantial improvement in process consistency, quality control, and financial performance, reinforcing the effectiveness of Lean tools in addressing persistent quality issues within fish canning operations.

Finally, as illustrated in Fig. 10, the OEE indicator initially stood at 63.2%, with a target of 85%. The experimentation closely approached the expectations, raising the OEE to 78.6%, which represents a 24% improvement.

The comparative analysis between the AS-IS and TO-BE models, based on 120 replications each, demonstrates a statistically significant reduction in the average batch cycle time. The AS-IS model reported an average of 712 min per batch (95% CI: [711, 713]), while the TO-BE model achieved a reduced average of 696 min per batch (95% CI: [696, 697]). This 16-min decrease in batch cycle time reflects the impact of the proposed Lean improvements, particularly the implementation of SMED and TPM strategies, as shown in Fig. 11.

As the batch cycle time directly influences throughput, this reduction enabled the system to process a higher number of batches within the same operational timeframe. Consequently, the number of cans produced per simulation period increased without requiring additional resources. Assuming the standard batch configuration of 26 cans and 10 operators working over an 8-h shift, this improvement translated into a measurable increase in system productivity.

The post-improvement simulation increase from approximately 6 to 7 cans per labor hour, representing a 17% improvement in labor efficiency. The narrow confidence intervals and the non-overlapping ranges between models confirm the statistical significance of this improvement. Therefore, the simulation results validate the effectiveness of the implemented Lean Manufacturing tools in optimizing operational performance and achieving the targeted productivity level.

IV. DISCUSSION

The implementation of Lean Manufacturing tools, specifically SMED and TPM, as part of a process improvement model had a significant positive impact on the productivity and operational efficiency of the fish canning plant under study. The main productivity indicator—the number of cans

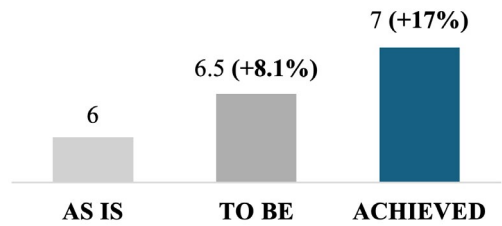

Fig. 6. Overall productivity indicator.

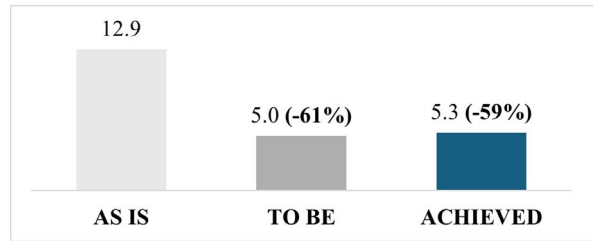

Fig. 7. Setup time indicator.

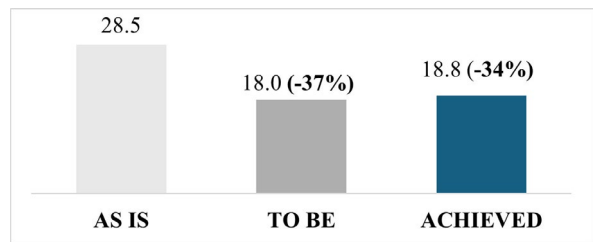

Fig. 8. Cycle time per batch indicator.

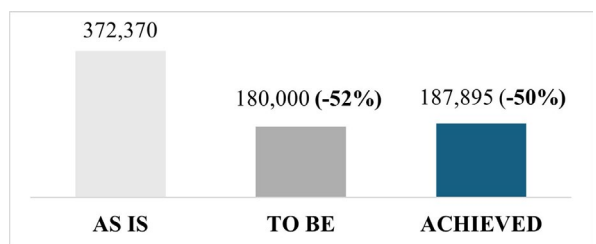

Fig. 9. Defective cans indicator.

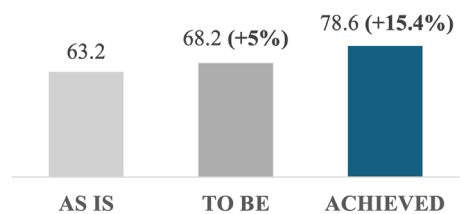

Fig. 10. OEE indicator.

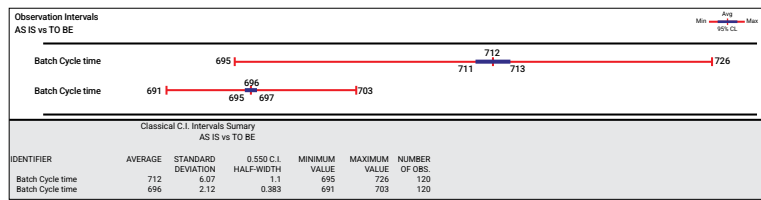

Fig. 11. Batch cycle time.

produced per batch—increased from 4,400 to 6,650 units, representing a 51% improvement. This outcome significantly exceeded initial expectations and is consistent with previous studies that highlight the effectiveness of lean manufacturing tools in improving operational efficiency such as a metalworking case study [6]. The success of the model lies in its capacity to address multiple factors simultaneously: reducing setup times, improving equipment availability, and minimizing process defects.

In the first component, focused on setup time management, the application of the SMED methodology enabled the classification, simplification, and standardization of internal setup activities. As a result, the setup time of the sealing machine was reduced from 12.9 to 5.3 min, a 59% reduction, almost reaching the targeted 5-min objective. This aligns with Shingo’s foundational work on SMED [7], as well as with findings by Arboleda and Rubiano [8], who reported similar reductions in the food sector.

The second component addressed preventive and autonomous maintenance under the TPM framework. Procedures, checklists, and staff training were implemented to reduce equipment failures and unplanned downtime. The availability rate increased from 70.4% to 85.2%, closing 91.7% of the performance gap toward the 90% target. Additionally, MTBF improved from 3.2 to 6.8 h, and MTTR decreased from 28 to 15 min, confirming increased equipment reliability and faster recovery. The number of unplanned shutdowns due to autoclave pressure failures decreased by 45%, while sealing mechanism malfunctions were reduced by 38%. These improvements demonstrate the effectiveness of the TPM plan in addressing the main sources of downtime and stabilizing the production system. Similar results were reported by Pinto *et al.* [9], who implemented a strategic TPM-based maintenance plan that reduced lathe breakdowns by 23% and machining center failures by 38%, while also improving OEE by 5%. Although the investment for this component was modest (USD 840), it is projected to save over USD 3,000 annually in lost production time.

Finally, it focused on defect reduction and error prevention. Root causes of defects, particularly in the sealing and thermal treatment stages, were identified and addressed through standard operating procedures and operator training. The defect rate decreased from 13% to 4.3%, representing a 50% reduction in defective units. This result supports Nakajima’s argument that empowering operators in maintenance and quality assurance directly improves

process reliability [10]. No significant equipment investments were required for this component, as improvements were achieved through non-monetary actions such as routine inspections and quality control checkpoints.

Despite the positive results, the study faced two main limitations: the lack of detailed historical operational data and the inability to conduct physical pilot testing due to real-time production constraints. Future research could address these limitations by performing on-site implementation trials or by using simulation platforms that model human variability and behavioral factors more realistically. Nevertheless, this study demonstrates that Lean Manufacturing tools, when adapted to the context of small-scale fish processors in Peru, can deliver measurable improvements in productivity, equipment performance, and product quality. These findings contribute valuable insights to both academic research and industrial application.

V. CONCLUSIONS

The implementation of Lean Manufacturing tools—specifically SMED and TPM—resulted in a significant improvement in the operational efficiency of the fish canning plant under study. The simulation demonstrated a 59% reduction in setup time and a 17% increase in productivity per batch, confirming the potential of SMED to streamline changeover processes and eliminate non-value-adding activities. These findings are consistent with the study by Monteiro *et al.* [6], who reported setup time reductions of 57% through the implementation of the SMED lean manufacturing tool.

In addition to time efficiency, the structured implementation of TPM led to notable gains in equipment performance. The increased MTBF and reduced MTTR reflect a more reliable and resilient maintenance system. These improvements are consistent with the outcomes reported by Campoverde-Pillajo *et al.* [11], who highlighted the benefits of autonomous maintenance and operator involvement in reducing process variability and machine downtime in a plastics extrusion line.

Furthermore, the model achieved a 49.5% reduction in defective units, improving both product quality and process stability. These results demonstrate how Lean tools can be effectively implemented in small-scale manufacturing contexts, even with limited resources. As shown in the

study by Canahua [12] and Hu *et al.* [13], the application of TPM and SMED strategies in Peruvian SMEs contributes to increasing OEE and fostering a culture of continuous improvement across the production system.

VI. REFERENCES

- [1] Ministerio de la Producción, “Anuario estadístico pesquero y acuícola 2024 [2024 Fisheries and aquaculture statistical yearbook],” Lima, Peru, 2024. [Online]. Available: <https://www.producempresarial.pe/anuario-estadistico-pesquero-y-acuicola-2024/>
- [2] E. F. Chavesta-Ayasta, D. Quispe-Victorio, y E. M. Avalos-Ortecho, "Application of lean manufacturing to increase productivity in a food sector company," in *Proc. 23rd LACCEI International Multi-Conference for Engineering, Education, and Technology: "Engineering, Artificial Intelligence, and Sustainable Technologies in service of society"*, Mexico City, Mexico, Jul. 16-18, 2025. <https://doi.org/10.18687/LACCEI2025.1.1.528>
- [3] G. Pinto, F.J.G. Silva, A. Baptista, Nuno O. Fernandes, R. Casais, C. Carvalho (2020) TPM implementation and maintenance strategic plan - a case study. *Procedia Manufacturing*. 51. p 1423-1430, doi: 10.1016/j.promfg.2020.10.198
- [4] N. M. Canahua Apaza, “Implementación de la metodología TPM-Lean Manufacturing para mejorar la eficiencia general de los equipos (OEE) en la producción de repuestos en una empresa metalmeccánica [Implementation of the TPM-Lean Manufacturing methodology to improve overall equipment effectiveness (OEE) in spare parts production in a metalworking company],” *Ind. Data*, vol. 24, no. 1, pp. 49-76, Aug. 2021, doi: 10.15381/idata.v24i1.18402.
- [5] R. Hernández-Sampieri, C. Fernández Collado, and P. Baptista Lucio, *Metodología de la investigación [Research Methodology]*, 6th ed. México, D.F., México: McGraw-Hill Interamericana, 2014.
- [6] C. Monteiro, L. P. Ferreira, N. O. Fernandes, J. C. Sá, M. T. Ribeiro, and F. J. G. Silve, “Improving the machining process of the metalworking industry using the lean tool SMED,” *Proc. Manuf.*, vol. 41, pp. 555-562, Mar. 2020, doi: 10.1016/j.promfg.2019.09.043.
- [7] S. Shingo, *A Revolution in Manufacturing: The SMED System*, 1st ed. New York, NY, USA: Routledge, 1985.
- [8] J. Arboleda Zúñiga and F. Rubiano del Chiaro, “Modelo propuesto para la implementación de la metodología SMED en una empresa de alimentos de Santiago de Cali [Proposed model for the implementation of the SMED methodology in a food company in Santiago de Cali],” *Rev. Investig.*, vol. 10, no. 2, pp. 103-117, Jul. 2017, doi: 10.29097/2011-639X.85.
- [9] G. Pinto, F. J. G. Silva, A. Baptista, N. O. Fernandes, R. Casais, and C. Carvalho, “TPM implementation and maintenance strategic plan - a case study,” *Proc. Manuf.*, vol. 51, pp. 1423-1430, Nov. 2020, doi: 10.1016/j.promfg.2020.10.198
- [10] S. Nakajima, *Introduction to TPM: Total Productive Maintenance*. Cambridge, MA, USA: Productivity Press, 1988.
- [11] C. D. Campoverde-Pillajo, P. G. Noboa-Romero, E. J. Toala-Guananga, N.-J. Plúa-Triviño, and M. J. Tapay-Mendoza, “Implementación del Mantenimiento Productivo Total en Extrusora Starex 1600 para reducir paradas y variaciones [Implementation of Total Productive Maintenance on a Starex 1600 extruder to reduce stoppages and variability],” *J. Econ. Soc. Sci. Res.*, vol. 4, no. 4, pp. 187-214, Oct. 2024, doi: 10.55813/gaea/jessr/v4/n4/141.
- [12] N. M. Canahua Apaza, “Implementación de la metodología TPM-Lean Manufacturing para mejorar la eficiencia general de los equipos (OEE) en la producción de repuestos en una empresa metalmeccánica [Implementation of the TPM-Lean Manufacturing methodology to improve overall equipment effectiveness (OEE) in spare parts production in a metalworking company],” *Ind. Data*, vol. 24, no. 1, pp. 49-76, Aug. 2021, doi: 10.15381/idata.v24i1.18402.
- [13] Q. Hu, R. Mason, S. J. Williams, and P. Found, “Lean implementation within SMEs: A literature review,” *J. Manuf. Technol. Manag.*, vol. 26, no. 7, pp. 980-1012, Sep. 2015, doi: 10.1108/JMTM-02-2014-0013.

BIOGRAPHICAL NOTES

FLAVIA ESPINOZA-MONTERO

Flavia Espinoza-Montero holds a Bachelor's degree in Industrial Engineering from Universidad de Lima. She currently works as a Key Account Executive in the Sales Department at Beiersdorf, where she manages strategic accounts and monitors key performance indicators (KPIs). She has experience in commercial strategy, data-driven decision-making, and cross-functional collaboration. Her main areas of interest include sales management, business analytics, process optimization, and continuous improvement.

RODRIGO RAFAEL QUINTANILLA-CHALAN

Rodrigo Rafael Quintanilla-Chalan is an Industrial Engineering student at Universidad de Lima. He currently works as a Sales Intern in the retail sector, where he is involved in activities related to commercial analysis and

management. His areas of interest include operations management, process improvement, industrial productivity, and commercial management.

JORGE ANTONIO CORZO-CHAVEZ

Jorge Antonio Corzo-Chavez holds a Master's degree in Business Administration from Universidad ESAN, Peru; a Master's degree in Marketing Science from ESIC Business & Marketing School, Spain; and a degree in Industrial Engineering from Universidad de Lima, Peru. He is currently a professor in the Industrial Engineering Program at Universidad de Lima and Chief Executive Officer at Conquista Lab. He has advised industrial and service companies on productivity improvement and business model development, and has worked in entrepreneurship, innovation, and commercial roles in the construction, mining, services, and education sectors. He has co-authored papers including "Improvement of Productivity by Applying 5S, Work Standardization, Ergonomic Analysis and Poka Yoke in a Metalworking Company," published in the Proceedings of the 23rd LACCEI International Multi-Conference for Engineering, Education, and Technology; "Production Model Based on Lean Manufacturing and Systematic Layout Planning to Reduce Waste in a Company in the Poultry Sector: A Case Study," published in the International Journal of Environmental Pollution and Remediation, volume 12; and "Model for Reducing Mean Absolute Percentage

Error through Smoothing and Time Series Forecasting in a Tourism SME: A Case Study," published in the Journal of Machine Intelligence and Data Science, volume 5. His main research interests are lean manufacturing, logistics, and machine learning for enterprises.

GINO VIACAVA-CAMPOS

Gino Viacava-Campos holds a Master's degree in Operations and Logistics from Universidad Peruana de Ciencias Aplicadas, Peru, and a degree in Industrial Engineering from Universidad de Lima, Peru. He is currently a professor in the Industrial Engineering Program at Universidad de Lima. He has experience in industrial and service companies, focusing on productivity improvement, business model development, and compensation system structuring. He has worked in human resources, operations, and logistics areas of a transnational company, both locally and overseas. As a consultant, he has experience in the construction, manufacturing, services, mining, commercial, finance, and education sectors. He has co-authored papers including "A Production Process Efficiency Improvement Model at a MSME Peruvian Metalworking Company," published in the Proceedings of the 2022 IEEE International Conference on Industrial Engineering and Engineering Management (IEEM). His main research interests are lean manufacturing, master production schedules, logistics, and compensation systems for small and medium-sized enterprises.

Resource Optimization in Urban Irrigation Systems: Reservoir and Clustering Techniques

Ariana E. Castro-Quispe¹ , Juan C. Quiroz-Flores² , Elsie V. Bonilla-Pastor³ 

¹20170331@aloe.ulima.edu.pe, ²jcquiroz@ulima.edu.pe, ³ebonilla@ulima.edu.pe

¹²³Carrera de Ingeniería Industrial, Universidad de Lima, Perú

Received: September 13, 2025 / Accepted: September 30, 2025 / Published: 5 June, 2026

doi: <https://doi.org/10.26439/ciii2025.8648>

ABSTRACT—Urban irrigation in a district of Lima currently relies on costly groundwater despite the availability of legacy canals. This study addresses rising unit costs by integrating a canal-fed reservoir with inventory model and k-means clustering for resource allocation. The design replaces the water source, sizes the reservoir using inventory-management logic, and relocates loading to a strategically ranked park. Using operational data from one representative day, the proposed scenario reduces labor cost, fuel cost and water cost. Measured outcomes include a reduction of 50.25% in labor, 26.03% in fuel and 90.8% in water costs along with an internal rate of return of 199%. Academically, the work links source substitution, inventory sizing, and clustering within a single engineering design; socio-economically, it offers a replicable pathway for municipalities. Municipalities should evaluate canal-fed storage and assignment analytics to unlock similar unit-cost reductions.

Index Terms—Clustering, cost efficiency, reservoir, resource optimization, urban irrigation.

I. INTRODUCTION

The rapid growth of the global population, combined with increasingly unpredictable climate patterns, has made sustainable water management one of the most pressing challenges of the 21st century. At present, water scarcity stems not only from the physical limitations of natural resources but also from economic constraints, such as insufficient investment in infrastructure and research [1]. Irrigation canals play a crucial role in sustaining vegetation and demonstrate multifunctional potential. For instance, recent studies have explored the installation of photovoltaic panels over canals to reduce evaporation while generating renewable energy [2], as well as the integration of hydrokinetic turbines, which can convert up to 78.53% of available hydraulic energy into usable power [3]. Furthermore, irrigation canals contribute to ecological restoration in rural areas

and enhance urban environments through the creation of green spaces, which have been associated with improved physical and mental well-being [4], [5].

Previous studies have modeled farmer responses to reservoir operation policies, showing that dynamic hedging strategies based on water performance forecasts effectively influence irrigation technology adoption, land use, and cost-benefit outcomes [6]. River-fed reservoirs offer a sustainable storage option; however, they face sediment accumulation challenges. For example, reservoirs in Poland lose approximately 0.1% of their capacity annually due to sedimentation [7].

In Lima, two principal pre-Hispanic irrigation canals remain: the Surco Canal and the Huatica Canal. The Surco Canal extends for 29.5 km and traverses 14 districts. Historically, it played a vital role in the ecosystem and agricultural development, but its significance has diminished in contemporary times [8]. Considering that Lima is the second largest city built in a desert, the presence and maintenance of these canals are of critical importance [9], [10].

The irrigation of public green areas, however, entails high operational costs and logistical inefficiencies. When water sources are geographically distant, extended transport routes are required, increasing both costs and delivery time. Consequently, route optimization becomes essential for improving resource efficiency. Related studies to route optimization and resource efficiency conducted in Argentina compared three algorithms for municipal waste collection and identified simulated annealing as the most effective approach for minimizing travel distance [11]. Similarly, research conducted in Canada applied genetic algorithms, FS-ACO, and Tabu search to optimize municipal sweeping routes, achieving significant reductions in fuel consumption, travel distance, and time [12]. In Chile, the application of the Ant Colony Optimization algorithm reduced travel distance by 23% and time by 22% [13]. Other approaches, such as Prim's heuristic [14] and Mixed-Integer Linear Programming, achieved a 19% reduction in total delivery

distance while considering constraints such as truck and product type [15]. In problems with many nodes, the Cluster-First Route Second (CC-CVRP) method has proven competitive and effective, particularly in medium-to-large problems, and remains one of the few feasible solutions for very large routing challenges [16], [17]. These findings suggest that assigning irrigation routes for tank trucks through optimized clustering and routing may significantly reduce travel time and operational inefficiencies.

A study conducted in China shows that the multi-objective genetic algorithm can accurately predict the demand trend and improve the inventory turnover rate [18]. Another study applied linear programming to forecast the demand of their product using inventory data as inputs [19].

Previous research has primarily focused on either reservoir design or routing optimization in isolation. There remains a lack of integrated approaches that simultaneously consider reservoir sizing, canal-fed water distribution, and cluster-based routing for urban irrigation systems. This gap is particularly relevant in Lima, where public green areas are currently irrigated using groundwater purchased at a unit cost of 1.85 PEN/m³, while canal-sourced water averages only 0.17 PEN/m³, representing a cost difference of 90.81%. Addressing this gap, the central problem guiding this study is how to reduce the unit cost of urban irrigation by integrating water supply alternative, reservoir design, and route clustering within a unified framework.

The novelty of this research lies in its holistic approach that combines reservoir sizing and clustering of irrigation areas into a single model. This integrated methodology offers three key contributions: it provides a replicable framework for metropolitan areas facing similar challenges; it demonstrates the measurable economic benefits of canal-fed irrigation; and it contributes to sustainability by reducing dependency on underground water sources. Accordingly, this study not only advances the state of the art but also provides practical insights for municipalities striving to balance cost-efficiency with environmental responsibility.

The remainder of this paper is organized as follows: Section II presents the methodology and engineering tools applied; Section III discusses the results; and Section IV highlights the main conclusions.

II. METHODOLOGY

This research is applied and correlational in nature, as it aims to reduce the unit cost of irrigation through the implementation of an alternative water source.

Firstly, the problem was identified, and the root causes were analyzed.

Subsequently, the data are collected. To define the unit of analysis, all irrigation routes carried out during a selected month were considered; simple random sampling was used

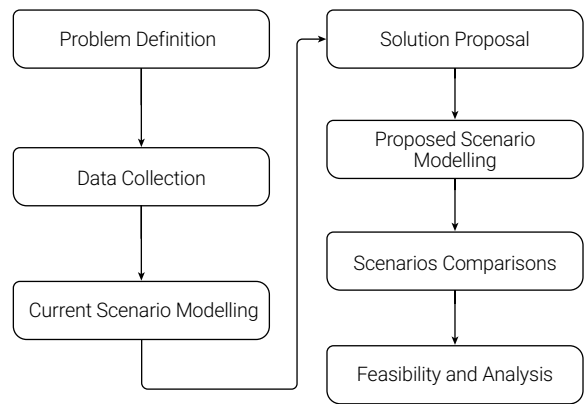

Fig. 1. Steps included in the research methodology.

to select a specific day considered as the unit of analysis. The stop points corresponding to the routes on the selected day were georeferenced.

The current scenario was modelled to determine the travel time and distance covered under the existing groundwater supply conditions.

Considering the water cost disparity, a solution was proposed based on the root causes of the problem.

The proposed solution consists of constructing a canal-fed reservoir. Potential parks suitable for reservoir construction were identified. For their selection, four relevant variables were defined and weighted using the factor ranking method. Once the most suitable site was selected, the structural design of the proposed reservoir was conceived. The reservoir volume was estimated using the maximum inventory formula (1), which requires the lot size (Q) and the safety stock (SS).

$$\text{Maximum inventory} = Q + SS \quad (1)$$

To calculate the safety stock (2), the following factors were considered: the desired service level, the average water demand, the demand standard deviation, the average canal inflow rate, and its standard deviations.

$$SS = Z * \sqrt{((D * \delta LT)^2 + (\sqrt{LT}) * \delta D)^2} \quad (2)$$

To model the proposed scenario, the travel time and distances were determined, and the new estimated cost of the water resource was calculated.

The logistical indicators of both scenarios were compared by calculating the reduction in travel time, distance travelled, water cost and carbon dioxide emissions.

Annual savings in labor, fuel and water costs were estimated. The initial investment, as well as the maintenance, and cleaning costs of the reservoir were averaged. Based on this information, the projected cash flow was developed and financial profitability indicators were calculated.

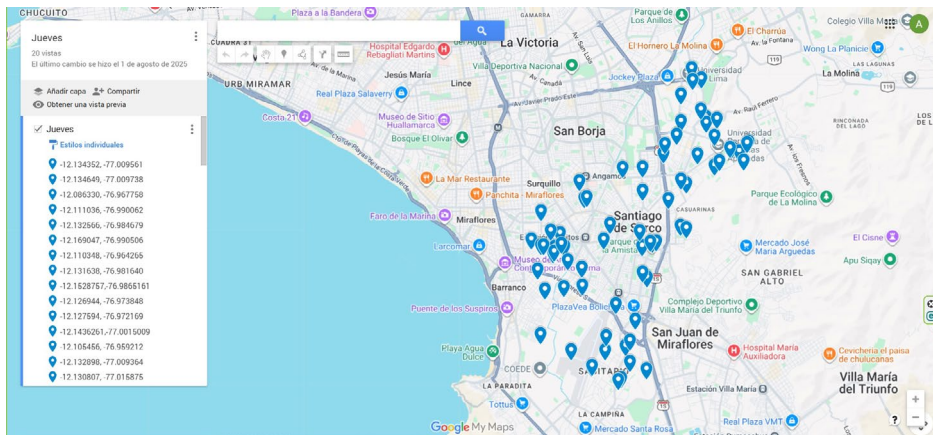

Fig. 2. Stops of the unit of analysis. Coordinates included in the single-day route analyzed.

TABLE I
INDICATORS OF CURRENT SCENARIO

Tank truck ID	Capacity	Time on route	Distance travelled	Water demand
SD-10	10,000 gal	4 h 20 min	141.8 km	60,000 gal
SD-11	10,000 gal	3 h 32 min	112.1 km	60,000 gal
SD-12	10,000 gal	4 h 19 min	135.2 km	60,000 gal
SD-13	10,000 gal	7 h 21 min	231.1 km	100,000 gal
SD-15	10,000 gal	3 h 34 min	111.2 km	50,000 gal
SD-17	10,000 gal	3 h 58 min	140.7 km	60,000 gal
SD-18	10,000 gal	4 h 11 min	124.1 km	60,000 gal
SD-20	10,000 gal	4 h 9 min	120.7 km	60,000 gal
SD-25	10,000 gal	3 h 35 min	98.6 km	50,000 gal
SD-30	5,000 gal	8 h 27 min	266 km	65,000 gal
SD-31	5,000 gal	7 h 53 min	252.1 km	55,000 gal
Total		55 h 19 min	1733.6 km	680,000 gal

Note: Time on route, distance travelled, and water demand for the single-day route are analyzed.

III. RESULTS

The company's current irrigation unit cost is high, as the groundwater used for irrigation is 90.81% more expensive than canal-supplied water. A canal known as Surco flows through the district, with a flow rate of 800 L/s, of which 200 L/s correspond to environmental flow. When tank trucks are loaded directly from the canal's main channel, the loading time reaches approximately 30 minutes for 10,000 gallons. This loading method generates traffic congestion, residents' complaints, and financial penalties for the company. The construction of a reservoir would increase the inlet flow rate, thereby reducing tank truck loading times.

Data were collected to quantify irrigation demand for public green areas, which totals 714,761.85 m³. Each green area should be irrigated twice per week during cold seasons and thrice per week during hot seasons. A unit of analysis is chosen, which is a day consisting of 80 routes carried out in

the year 2025 during the month of March. The coordinates of the stops were identified. This route irrigates approximately 238,254 m³, representing 33.33% of the total demand. The tank trucks with a capacity of 10,000 gallons service 70% of the stops assigned; the remaining 30% of the stops are made by tank trucks with a capacity of 5,000 gallons.

Currently the water supply is in the coordinate -12.18763, -76.972691. Eleven tank trucks start their routes simultaneously, each operated by one driver and one assistant.

The indicators for the actual scenario are calculated. The travel time is 55 h 19 min, and the total man-hours are 110 h 38 min, given that each route is operated by two personnel. The travel time refers to the driving time on the assigned route. The total distance travelled is 1,733.6 km.

Three potential sites were identified as possible locations for the reservoir: Filomeno Ormeño, De los Ingenieros, and María Reiche.

TABLE II
FACTOR RANKING FOR EACH POTENTIAL LOCATION

Variables	W ^a	Filomeno Ormeño		De los Ingenieros		María Reiche	
		S ^b	W × S ^c	S	W × S	S	W × S
Distant residential areas	40%	5	200	5	200	5	200
Near canal	20%	9	180	8	160	7	140
Space availability	20%	7	140	7	140	7	140
Proximity to green areas	20%	9	180	9	180	9	180
Total	100%		700		680		660

Note: The score indicates the extent to which the factor is fulfilled.

^a W = Weight of factor

^b S = Score of potential location according to each factor

^c W × S = Multiplication of weight and the score

The proposed site for building the reservoir is Filomeno Ormeño Park, located at coordinates are -12.120952, -76.997572.

To calculate the volume of the reservoir, the maximum inventory formula (1) is used. Four variables are required to calculate the safety stock (2). The demand and its standard deviation are obtained using historical route data. Lead time corresponds to the loading duration of a tank and is generally assumed to be constant, implying no deviation. Two safety stocks were calculated: one for tank trucks of 10,000 gallons of capacity and another one for tank trucks of 5,000 gallons of capacity. For both calculations a service level of 95% was applied.

TABLE III
VARIABLES FOR SAFETY STOCK FORMULA 1

Variables	Original value	Adjusted value ^a
Demand ^b	692,500 gal/day	692,500 gal/day
Demand deviation ^b	109,792.3 gal/day	109,792.3 gal/day
Lead time ^b	25 min	0.01736 days
Lead time deviation ^b	-	-

^a The values were adjusted to be consistent with the formula.

^b Lead time and deviation of the tank trucks with a capacity of 10,000 gallons of water.

$$SS_1 = 1.645 * \sqrt{\left(\left(\frac{692,500 \text{ gal}}{\text{day}} * 0\right)^2 + \left(\sqrt{0.01736 \text{ day}} * \frac{109,792.3 \text{ gal}}{\text{day}}\right)^2\right)} \quad (3)$$

$$SS_1 = 23,796.48 \text{ gal}$$

The safety stock for tank trucks with a capacity of 10,000 gallons of water was calculated as 23,796.48 gallons using formula (2).

The lot size for tank trucks (Q) corresponds to their capacity, which in this case is 10,000 gallons.

$$\begin{aligned} \text{Maximum inventory}_1 &= 10,000 \text{ gal} + 23,796.48 \text{ gal} \\ \text{Maximum inventory}_1 &= 33,796.48 \text{ gal} \end{aligned} \quad (4)$$

The maximum inventory to supply the demand of tank trucks with a capacity of 10,000 gallons was calculated as 33,796.48 gallons using the formula (1).

TABLE IV
VARIABLES FOR SAFETY STOCK FORMULA 2

Variables	Original value	Adjusted value ^a
Demand ^b	48,750 gal/day	48,750 gal/day
Demand deviation ^b	10,451.8 gal/day	10,451.8 gal/day
Lead time ^b	12.5 min	0.00868 days
Lead time deviation ^b	-	-

^a The values were adjusted to be consistent with the formula.

^b Lead time and deviation of the tank trucks with a capacity of 5,000 gallons of water.

$$\begin{aligned} SS_2 &= 1.645 * \sqrt{\left(\left(\frac{48,750 \text{ gal}}{\text{day}} * 0\right)^2 + \left(\sqrt{0.00868 \text{ day}} * \frac{10,451.8 \text{ gal}}{\text{day}}\right)^2\right)} \\ SS_2 &= 1,601.83 \text{ gal} \end{aligned} \quad (5)$$

The safety stock for the tank trucks with a capacity of 5,000 gallons of water was calculated as 1,601.83 gallons using formula (2).

The lot size for tank trucks (Q) corresponds to their capacity; which in this case is 5,000 gallons.

$$\begin{aligned} \text{Maximum inventory}_2 &= 5,000 \text{ gal} + 1,601.83 \text{ gal} \\ \text{Maximum inventory}_2 &= 6,601.83 \text{ gal} \end{aligned} \quad (4)$$

TABLE V
INDICATORS OF THE PROPOSED SCENARIO

Tank truck ID	Capacity	Travel Time	Distance travelled	Water demand
SD-10	10,000 gal	2 h 38 min	56.2 km	60,000 gal
SD-11	10,000 gal	3 h 25 min	76 km	60,000 gal
SD-12	10,000 gal	3 h 4 min	66.9 km	60,000 gal
SD-13	10,000 gal	5 h 15 min	108.6 km	100,000 gal
SD-15	10,000 gal	2 h 24 min	50.7 km	50,000 gal
SD-17	10,000 gal	3 h 13 min	71.2 km	60,000 gal
SD-18	10,000 gal	2 h 42 min	54.9 km	60,000 gal
SD-20	10,000 gal	2 h 48 min	56.9 km	60,000 gal
SD-25	10,000 gal	2 h 56 min	62.7 km	50,000 gal
SD-30	5,000 gal	6 h 54 min	146.1 km	65,000 gal
SD-31	5,000 gal	5 h 36 min	112.3 km	55,000 gal
Total		40 h 55 min	862.5 km	680,000 gal

Note: Travel time, distance, and water demand for the proposed routes supplied by the canal-fed reservoir are analyzed.

TABLE VI
COMPARISON OF SCENARIOS

Indicators	Current scenario	Proposed scenario	Improvement rate
Time on route	55 h 19 min	40 h 55 min	26.03%
Distance travelled	1,733.6 km	862.5 km	50.25%

Note: The indicators are calculated for both scenarios.

The maximum inventory to supply the demand of tank trucks with a capacity of 5,000 gallons was calculated as 6,601.83 gallons using formula (1).

$$\begin{aligned}
 \text{Total maximum inventory} &= \\
 &33,796.48 \text{ gal} + 6,601.81 \text{ gal} \quad (4) \\
 \text{Total maximum inventory} &= 40,398.29 \text{ gal}
 \end{aligned}$$

The proposed reservoir capacity is 40,398.29 gallons, equivalent to 152.96 m³.

The Surco Canal currently presents a moderate level of pollution due to the discharge of wastewater and domestic effluents [20]. It is proposed that the reservoir incorporates an inlet grate to trap large solid debris. In addition, the implementation of steeply inclined settlers is proposed to reduce suspended sediments. These settlers are installed at angles between 45° and 60° relative to the horizontal and consist of tube-like channels with a width of 5 cm and a length of approximately 2 m [21].

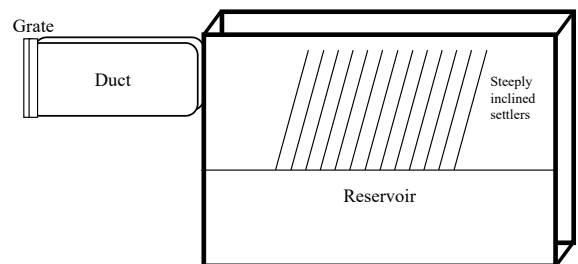

Fig. 3. The settlers within the reservoir cross-section are inclined to increase the effective settling velocity of suspended matter, thereby improving sedimentation efficiency.

The reservoir is designed to supply the total demand of public green areas. The travel time and distance were calculated considering the reservoir located at the coordinates $-12.120952, -76.997572$.

The indicators for the proposed scenario are calculated. The travel time is 40 h 55 min, and the total man-hours is 81 h 50 min considering that two operators accompany each route. The total distance is 862.5 km.

Both scenarios are compared, and the improvement rates are quantified.

Additionally, the economic impact of resource optimization is evaluated. The labor cost is 15 PEN per man-hour, with two personnel assigned to each route. The tank trucks consume one gallon of fuel every 5 km traveled, and the fuel cost is 13.12 PEN per gallon. The unit cost of canal-sourced water is 0.17 PEN/m³ [12]. The capacity of each tank truck is 10,000 gallons, equivalent to 37.85 m³.

TABLE VII
COSTS OPTIMIZATION OF THE PROPOSED SCENARIO

Costs	Current scenario	Proposed scenario	Improvement rate
Labor costs ^a	1,659.5 PEN	1,227.5 PEN	26.03%
Fuel cost ^a	4,549 PEN	2,263 PEN	50.25%
Water cost ^a	4,760 PEN	438 PEN	90.8%

Note: The costs are calculated considering the indicators for both scenarios.

^a Costs per day.

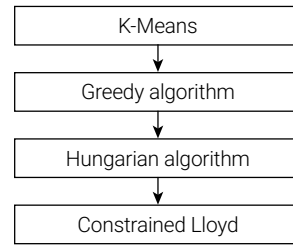

Fig. 4. Code structure. The main algorithm used is k-means.

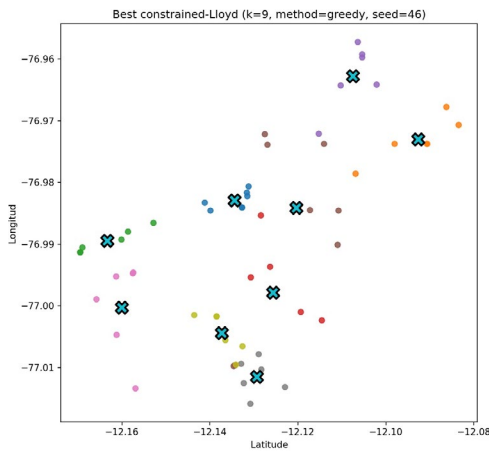

Fig. 5. Scatter plot 1. The centroids in the scatter plot represent the average coordinate for each cluster.

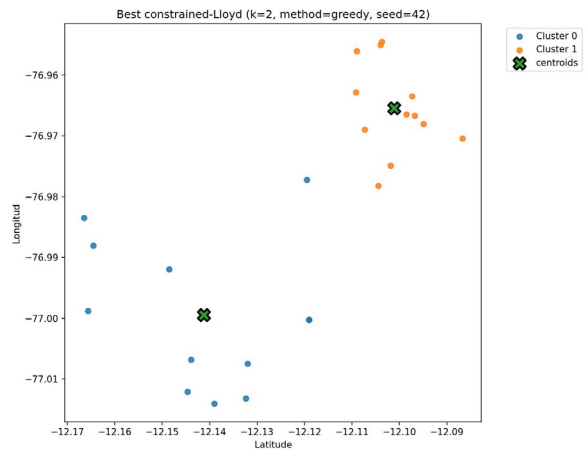

Fig. 6. Scatter plot 2. The centroids in the scatter plot represent the average coordinate for each cluster.

Clustering is proposed to reduce the learning curve by assigning each cluster to a tank truck. The inputs consist of the coordinates of the green areas, while the outputs include scatter plots and an Excel file grouping the coordinates according to each cluster. The number of clusters is equal to the number of tank trucks: nine for trucks with a capacity of 10,000 gallons and two for trucks with a capacity of 5,000 gallons. The algorithm begins with k-means to initialize the centroids. A greedy algorithm is then applied to enforce capacity constraints within each cluster. Subsequently, the Hungarian algorithm is used to minimize the overall travel distance. Finally, the constrained Lloyd algorithm performs iterative restarts and updates the centroids.

The following figures present the clustering results, in which each cluster is assigned to a tank truck. The first scatter plot corresponds to tank trucks with a capacity of 10,000 gallons while the second corresponds to tank trucks with a capacity of 5,000 gallons.

The inputs, outputs, and source codes are available at: <https://drive.google.com/drive/>

folders/1hSPFviV1S91n1tg3uJxEmNRodBBB-fvP?usp=sharing

The project cash flow for the next three years begins with the operating phase of the reservoir. The proposed reservoir is similar in size and structural characteristics to one previously constructed in another district of Lima, for which public investment information is available [22]; therefore, the same investment amount was adopted. The construction permit is issued by the National Water Authority of Peru (Autoridad Nacional del Agua, ANA) [23]. A reservoir scraper system is proposed to facilitate cleaning operations. This technology enables the continuous removal of sludge from the bottom of the reservoir. In addition, the construction of a parking area for two tank trucks is considered essential to prevent traffic congestion. Finally, the presence of a technician responsible for cleaning, maintenance, and security of the reservoir is required.

The costs for the proposed scenario are calculated on a daily basis. Irrigation is carried out six days per week, over 4.3 weeks per month, and twelve months per year.

TABLE VIII
ECONOMIC FLOW RATES

In PEN	Year 0	Year 1	Year 2	Year 3
<i>Expenses</i>				
Reservoir	-975,000			
Reservoir scrapper	-40,000			
Restroom	-13,000			
Permit for a reservoir	-500			
Parking for tank trucks	-8,000			
Security and cleaning staff		36,000	36,000	36,000
<i>Savings</i>				
Man-hour cost		133,747	133,747	133,747
Fuel cost		707,746	707,746	707,746
Water cost		1,338,091	1,338,091	1,338,091
Total	-1,036,500	2,143,584	2,143,584	2,143,584

Note: The differences in the daily cost indicators (Table VII) are used to calculate the annual savings. The expenses are averaged based on the Peruvian market values.

The cash flow indicates an internal return rate of 199%. The social impact of the reservoir includes the provision of efficient urban irrigation services using an alternative water source. The reservoir will be available for firefighting purposes when required. The construction of the reservoir will slightly reduce the area of public green spaces. From an environmental perspective, the project achieves a 50.22% reduction in carbon dioxide emissions.

IV. DISCUSSION

The high values of the economic indicators obtained in this study are primarily explained by the fact that the positive cash flow results from cost savings rather than direct revenues [24]. Similar conclusions have been reported in Valparaíso, where strategically located reservoirs play a key role in ensuring timely access to water for firefighting, thus generating both economic and social benefits [25]. While most previous research has concentrated mainly on resource optimization, this study incorporates environmental considerations, such as carbon dioxide emissions, which are often overlooked [26]. In comparison, other studies applying routing techniques estimate emissions using vehicle speed functions [27], whereas in this research the analysis was conducted directly based on the distance travelled. Although this approach provides a practical estimation, speed-based functions could yield a more accurate assessment of improvement rates. Furthermore, comparative studies analyzing scenarios with a single large reservoir versus multiple smaller reservoirs have shown that the single-reservoir configuration achieves higher economic efficiency due to lower construction and operational costs [28], which is consistent with the methodology used. Additional

studies highlight the role of suspended sediment loads and mass conservation principles in reservoir calculations [29], as well as the reuse of bottom sediments in croplands, which enhances soil properties and irrigation efficiency [30]. These findings are consistent with the present research and suggest opportunities for further refinement.

Despite these promising outcomes, the study has several limitations. The analysis was conducted within a single district in Lima, which restricts the generalizability of the findings to other urban contexts. Moreover, for model simplification, external factors such as weather variability, vehicle maintenance, and traffic congestion were not considered. The results also rely on the assumption of a constant and reliable canal inflow, which may not always be maintained in real operating conditions.

In practical terms, the proposed model demonstrates strong potential to reduce irrigation costs while simultaneously addressing environmental impacts. Its application can be extended to municipal decision-making processes, particularly in contexts where water scarcity and financial constraints coexist. Furthermore, integrating the reservoir as a dual-purpose infrastructure—supporting both irrigation and firefighting operations—highlights its societal relevance.

Future research should address the identified limitations identified by incorporating weather conditions, transportation constraints, and more advanced emission models into the optimization framework. Expanding the geographical scope to multiple districts or even to metropolitan scales would strengthen the external validity of the results. Finally, the inclusion of sediment reuse strategies and advanced routing algorithms could further enhance both the environmental sustainability and the operational efficiency of the proposed model.

V. CONCLUSIONS

This study demonstrates that integrating a canal-fed reservoir with route redesign is an effective strategy to reduce the irrigation unit cost of urban green areas. The proposed model achieves a 26.03% decrease in labor costs, 50.25% reduction in fuel consumption cost and a 90.8% drop in water costs compared with the current groundwater-based system. Additionally, fuel savings contribute to a 50.2% reduction in CO₂ emissions, while the economic evaluation confirms strong feasibility with an internal rate of return of 199%. These results validate the proposed model as a practical and replicable approach for municipalities operating under both budgetary and environmental constraints.

The importance of this research lies in addressing the challenge of costly irrigation practices in desert cities such as Lima by linking water resource substitution with operational optimization. The study highlights the potential of industrial engineering to provide solutions that are simultaneously efficient, sustainable, and economically viable.

The main contribution of the work lies in the methodological integration of reservoir sizing and clustering for vehicle assignment, which together deliver measurable performance improvements. Future research should evaluate seasonal variability, incorporate real-time monitoring technologies, and assess the social acceptance of canal-fed reservoirs to enhance long-term applicability.

This study analyzes the economic benefits of having a water supply close to final location, as well as shifting to balanced driver assignments and clustering to achieve efficient and timely operations.

For future research, it is recommended to incorporate additional constraints into the model. Interdisciplinary studies are encouraged, including regulatory compliance, alternative structural designs, and community acceptance.

ACKNOWLEDGEMENT

I would like to express my sincere gratitude to Professor Elsie Bonilla-Pastor and Professor Juan C. Quiroz-Flores for their guidance and contributions to my academic development. I am deeply grateful to Paola Castro and Christian Ortiz, whose assistance in providing the company's performance indicators was essential to the completion of this study. I also extend my appreciation to the municipalities of Santiago de Surco and San Borja for their collaboration and support throughout this research.

REFERENCES

- [1] A. Mehallel and V. Feliu-Battle, "Reducing the impacts of withdrawals on the water distribution in main irrigation canals based on a modified Smith predictor control scheme," *Water*, vol. 17, no. 3, p. 373, Jan. 2025, doi: 10.3390/w17030373.
- [2] A. Kaab, H. Ghasemi-Mobtaker, M. Sharifi, and U. Jørgensen, "Evaluating the viability of installing photovoltaic panels on irrigation canals for energy generation and water storage," *Energy Nexus*, vol. 18, p. 100455, Jun. 2025, doi: 10.1016/j.nexus.2025.100455.
- [3] E. Peralta-Escobar, S.-R. Galván-González, G. Solorio-Díaz, N.-D. Herrera-Sandoval, and D. Cahue-Díaz, "Estimation of the electrical energy provided by an irrigation canal with the design of a hydrokinetic turbine," *IEEE Lat. Am. Trans.*, vol. 23, no. 1, pp. 58–67, Jan. 2025, doi: 10.1109/TLA.2025.10810396.
- [4] J. Dostálek, T. Frantík, and L. Pavlů, "Passive restoration of vegetation on gravel/sand bars in the city: A case study in Prague, Czech Republic," *Urban Ecosyst.*, vol. 25, no. 4, pp. 1265–1277, Apr. 2022, doi: 10.1007/s11252-022-01225-8.
- [5] W. Lin et al., "The effect of green space behaviour and per capita area in small urban green spaces on psychophysiological responses," *Landsc. Urban Plann.*, vol. 192, p. 103637, Dec. 2019, doi: 10.1016/j.landurbplan.2019.103637.
- [6] E. Ebrahimi and M. Shourian, "Modeling farmer responses to reservoir operation policies using agent based analysis of risk behavior and irrigation adoption," *Sci. Rep.*, vol. 15, no. 1, Jul. 2025, doi: 10.1038/s41598-025-11908-9.
- [7] Ł. Pieron, D. Absalon, M. Habel, and M. Matysik, "Inventory of reservoirs of key significance for water management in Poland—Evaluation of changes in their capacity," *Energies*, vol. 14, no. 23, p. 7951, Nov. 2021, doi: 10.3390/en14237951.
- [8] K. S. B. Peña Medrano, "Ecosistema urbano canal: renaturalización y reintegración del canal de Surco en Lima [Urban canal ecosystem: renaturalization and reintegration of the Surco canal in Lima]," Professional degree thesis, Pontif. Univ. Católica del Perú, Lima, Peru, 2022. [Online]. Available: <http://hdl.handle.net/20.500.12404/22292>
- [9] J. Lizarzaburu, "The Surco canal, an ancient irrigation canal in Lima, Peru, and a citizens' campaign for its protection," *Water Hist.*, vol. 12, no. 3, pp. 299–310, Nov. 2020, doi: 10.1007/s12685-020-00257-1.
- [10] Comisión de Regantes Surco, Lima, Peru. *Video Sobre el Riego en Áreas Verdes del Distrito de Surco* [Video on Irrigation in Green Areas of the Surco District]. (Aug. 25, 2018). [Online Video]. Available: <https://www.facebook.com/regantessurco/videos/282427792354882>
- [11] D. G. Rossit, A. A. Toncovich, and M. Fermani, "Routing in waste collection: A simulated annealing algorithm

- for an Argentinean case study,” *Math. Biosci. Eng.*, vol. 18, no. 6, pp. 9579–9605, Nov. 2021, doi: 10.3934/mbe.2021470.
- [12] T. Parsons, J. Seo, and D. Livesey, “Municipal street-sweeping area generation with route optimization,” *Int. Trans. Oper. Res.*, vol. 32, no. 3, pp. 1375–1399, Jul. 2024, doi: 10.1111/itor.13515.
- [13] C. Oliva, M. Cepeda, and S. Muñoz-Herrera, “Coordinated truck loading and routing problem: A forestry logistics case study,” *Math.*, vol. 13, no. 15, p. 2537, Aug. 2025, doi: 10.3390/math13152537.
- [14] A. Ganesan and A. Narasimhamurthy, “An algorithm for the multi-depot, multi-vehicle routing problem with capacity constraints,” in *Proc. 3rd IEEE World Conf. Appl. Intell. Comput. (AIC)*, Jul. 2024, pp. 54–59, doi: 10.1109/AIC61668.2024.10730945.
- [15] S. Prachyathawornkul, A. Apichottanakul, and K. Pitiruek, “Improving delivery planning via an optimization technique for a case study of a construction material store,” *Cogent Eng.*, vol. 10, no. 1, Jul. 2023, doi: 10.1080/23311916.2023.2231725.
- [16] M. Shalaby, A. Mohammed, and S. Kassem, “Supervised fuzzy C-means techniques to solve the capacitated vehicle routing problem,” *Int. Arab J. Inf. Technol.*, vol. 18, no. 3A, pp. 452–463, Jan. 2021, doi: 10.34028/iajit/18/3a/9.
- [17] F. Alesiani, G. Ermis, and K. Gkiotsalitis, “Constrained clustering for the capacitated vehicle routing problem (CC-CVRP),” *Appl. Artif. Intell.*, vol. 36, no. 1, pp. 1–25, Jan. 2022, doi: 10.1080/08839514.2021.1995658.
- [18] L. Fan et al., “Change is safer: a dynamic safety stock model for inventory management of large manufacturing enterprise based on intermittent time series forecasting,” *J. Intell. Manuf.*, vol. 36, pp. 3983–4003, Jun. 2024, doi: 10.1007/s10845-024-02442-y.
- [19] N. Somjai, P. Rueangsrirai, and R. Homchalee, “Optimizing production and inventory planning of concentrated wild mushroom leavening agents to maximize annual sales using linear programming,” *GMSARN Int. J.*, vol. 19, no. 3, pp. 466–475, Sep. 2025. [Online]. Available: <http://gmsarnjournal.com/home/wp-content/uploads/2024/12/vol19no3-8.pdf>
- [20] J. V. Yon Leiva and J. A. Arenas Ibarra, “Evaluación de la calidad del agua en el canal Surco de la Zona de Reglamentación Especial del Humedal Los Pantanos de Villa (Lima, Perú) [Water quality assessment of the Surco canal in the Special Regulation Zone of the Los Pantanos de Villa wetland (Lima, Peru)],” *South Sustain.*, vol. 5, no. 1, e090, 2024, doi: 10.21142/SS-0501-2024-e090.
- [21] C. F. Ihle and C. Reyes, “A new criterion to estimate the capacity of steeply inclined settlers of arbitrary cross-sectional shape,” *Powder Technol.*, vol. 397, p. 117004, Jan. 2022, doi: 10.1016/j.powtec.2021.11.048.
- [22] Panamericana Televisión, “La Victoria: Construye reservorio subterráneo de agua para riego de áreas verdes [La Victoria: Construction of an underground water reservoir for irrigation of green areas],” *Panamericana Televisión*, Sep. 3, 2020. [Online]. Available: <https://panamericana.pe/24horas/locales/302170-victoria-construye-reservorio-subterraneo-agua-riego-areas-verdes>
- [23] Autoridad Nacional del Agua. “Permisos. Uso de agua superficial o subterránea [Permits: Use of surface or groundwater].” *Gob.pe*. [Online]. Available: <https://www.gob.pe/institucion/ana/tema/permisos/uso-de-agua-superficial-o-subterranea>
- [24] Q. Sun, “Application analysis of internal rate of return capital budgeting method in project investment decision-making,” *BCP Bus. Manag.*, vol. 35, pp. 6–10, Dec. 2022, doi: 10.54691/bcpbm.v35i.3219.
- [25] M. Alfaro, P. Santander, G. Fuertes, R. Ternerero, and M. Vargas, “Water reservoir placement methodology for forest firefighting: a case study of Valparaíso, Chile,” *Forests*, vol. 15, no. 1, p. 201, Jan. 2024, doi: 10.3390/f15010201.
- [26] J. Chazarra-Zapata, J. M. Molina-Martínez, F.-J. Pérez de la Cruz, D. Parras-Burgos, and A. Ruíz Canales, “How to reduce the carbon footprint of an irrigation community in the south-east of Spain by use of solar energy,” *Energies*, vol. 13, no. 11, p. 2848, Jun. 2020, doi: 10.3390/en13112848.
- [27] Z. Yao, H. Cao, Z. Cui, Y. Wang, and N. Huang, “Research on urban distribution routes considering the impact of vehicle speed on carbon emissions,” *Sustainability*, vol. 14, no. 23, p. 15827, Nov. 2022, doi: 10.3390/su142315827.
- [28] A. M. Takeleb, J. Sujono, and R. Jayadi, “Evaluation of reservoir capacity and reliability for urban water purpose in Dili, Timor Leste,” *J. Civ. Eng. Forum*, vol. 1000, no. 1000, Dec. 2020, doi: 10.22146/jcef.58538.
- [29] E. Somathilake and M. Diagne, “Output feedback control of suspended sediment load entrainment in water canals and reservoirs,” *IFAC-PapersOnLine*, vol. 58, no. 28, pp. 983–988, Jan. 2024, doi: 10.1016/j.ifacol.2025.01.124.
- [30] C. Gomez et al., “Reuse of bottom sediment from reservoirs to cropland is a promising agroecological practice that must be rationalized,” *Sci. Rep.*, vol. 15, no. 1, Mar. 2025, doi: 10.1038/s41598-025-92206-2.

BIOGRAPHICAL NOTES

ARIANA ESTHER CASTRO QUISPE

Ariana Esther Castro Quispe holds a Bachelor's degree in Industrial Engineering from Universidad de Lima, Peru. Her research interests focus on machine learning.

JUAN CARLOS QUIROZ-FLORES

Juan Carlos Quiroz-Flores holds a PhD in Business Management from Universidad Nacional Mayor de San Marcos, a Master's degree in Business Administration from ESAN Graduate School of Business, and a degree in Industrial Engineering from Universidad de Lima, with certifications in Lean Six Sigma and Lean Manufacturing. He is a Research Professor and Coordinator of Degrees and Diplomas at Universidad de Lima, with more than 140 articles indexed in Scopus and Web of Science. He is a full member of Sigma Xi, in recognition of his scientific output, and a member of Beta Gamma Sigma for academic excellence in his graduate studies. He specializes in lean supply chain, process improvement, and productivity, and has more than 20 years of experience in operations management in manufacturing, services, and retail companies.

ELSIE VIOLETA BONILLA PASTOR DE CÉSPEDES

Elsie Violeta Bonilla Pastor de Céspedes holds a PhD in Accounting and Business Sciences from Universidad Nacional Mayor de San Marcos, a Master's degree in Industrial Engineering from Universidad Nacional Federico Villarreal, and a degree in Industrial Engineering from Universidad Nacional de Ingeniería. She is Director of Planning and Accreditation, Full Professor, and Researcher at Universidad de Lima, where she has collaborated for 35 years. She is also a business consultant and has held managerial positions in production planning and control and quality in the manufacturing sector. Her recent publications include "Climate Action in Higher Education: Advancing Sustainable Development through an International Research Consortium" (International Journal of Sustainability in Higher Education, December 2025) and "Optimization of Management in Consulting Firms through Lean Office to Reduce Rework" (Ingeniería Industrial, no. 49, Universidad de Lima, December 2025). She is co-author of the book Continuous Process Improvement: Tools and Techniques (Fondo Editorial de la Universidad de Lima, 2010). Her consulting and research interests include process optimization with a sustainability focus, Lean Manufacturing, and the implementation of Integrated Management Systems. She is a Lead Evaluator of the National 5S Kaizen Award (AOTS) and a member of the Mipyme Committee of Inacal.

Improvement Proposal to Increase On-Time Delivery in a Textile SME through the Implementation of Poka-Yoke, SMED, and Standard Work

Paul M. Yauri-Artica¹ , Nicol C. Melgar-Barrios² , Gino Viacava-Campos³ , Jorge A. Corzo-Chavez⁴ 

¹20203856@ulima.edu.pe, ²20203955@ulima.edu.pe, ³geviacav@ulima.edu.pe, ⁴jacorzo@ulima.edu.pe

¹²³⁴Carrera de Ingeniería Industrial, Universidad de Lima, Perú

Received: July 27, 2025 / Accepted: September 30, 2025 / Published: 5 June, 2026

doi: <https://doi.org/10.26439/ciii2025.8649>

ABSTRACT—This study presents a process improvement project in a Peruvian textile small and medium-sized enterprise (SME) specialized in knitted garments. The company operates with an On-Time Delivery (OTD) rate of 53.05%, which is significantly below the industry benchmark of 77%. This low performance is exacerbated by excessive setup times and high defect rates, which negatively affect production efficiency and process reliability. To address these challenges, a tailored Lean model was developed by integrating Single-Minute Exchange of Die (SMED), Poka-Yoke, and Standard Work, adapted to the company's semi-manual operations. The main contribution of this study is to demonstrate that the combined and contextualized application of these tools can effectively reduce performance gaps in resource-constrained manufacturing environments. After simulation and pilot testing, the model achieved a 24.95-point increase in OTD, reaching 78%, along with reductions in setup time and operational variability.

Index Terms—Lean Manufacturing, On-Time Delivery, Poka-Yoke, SMED, SME textile, Standard Work.

I. INTRODUCTION

In today's highly competitive and time-sensitive textile industry, small manufacturers must optimize their internal processes to meet increasing customer expectations and market demands [1]. This paper presents a data-driven process improvement project conducted in a Peruvian SME specializing in knitted garment production. The study addresses key inefficiencies that impact On-Time Delivery (OTD), including excessive setup times, operator-dependent variability, and lack of standardized work procedures. By integrating Single-Minute Exchange of Die (SMED),

Poka-Yoke, and Standard Work methodologies, the project achieved significant improvements in productivity, quality, and delivery performance, thereby strengthening the company's operational reliability [1].

According to data from PROMPERÚ and the Sociedad Nacional de Industrias (SNI), the Peruvian textile sector accounts for more than 10% of the national manufacturing GDP and employs over 400,000 people across the value chain. However, small and medium-sized enterprises (SMEs), which account for over 85% of textile producers, face systemic challenges in productivity and delivery performance. Studies indicate that the average OTD rate in the Peruvian textile sector is approximately 77%, while lot changeover times in semi-manual operations frequently exceed 40-45 min [1]. Additionally, defect rates in similar SMEs typically range from 4 to 7%, depending on operator skill and lack of standardization. These figures highlight the gap between current practices and the competitive benchmarks required for sustained export growth.

Currently, the company faces several operational inefficiencies, including extended lot changeover times averaging 50 min, recurring human errors resulting in a 5% defect rate, and an OTD level of 53.05%, which is well below the industry benchmark of 77% [1]. While a number of studies has shown the effectiveness of Lean Manufacturing tools—such as SMED, Poka-Yoke, and Standard Work—in improving production metrics in the textile sector [2], [3], most reported applications are either isolated, generic, or designed for large-scale automated environments [4]. In that sense, their direct application to the context of small, semi-manual operations such as those of the studied SME, remains limited or suboptimal.

Based on these limitations, this study proposes a tailored and integrated improvement model that combines

SMED, Poka-Yoke, and Standard Work, specifically adapted to the company's operational reality. The objective is not only to reduce setup times and prevent process errors but also to establish a standardized work system that can be sustained over time and scaled across similar settings. The research contribution is to demonstrate the effectiveness of low-cost, high-impact interventions in environments with limited automation [5].

The remainder of this paper is structured as follows: Section II describes the methodology applied, including the design of the intervention and data collection procedures. Section III presents the results obtained from simulation and pilot testing. Section IV discusses the implications of the findings and compares them with previous research.

II. METHODOLOGY

A. Research Design and Methodology

This study adopts an applied, quantitative research design, aimed at addressing real inefficiencies in a Peruvian SME through the implementation of Lean Manufacturing tools. Operational data, including setup times, defect rates, and process variability, were collected and analyzed to explain how the integrated application of SMED, Poka-Yoke, and Standard Work improves OTD. The research has a correlational scope, as it examines the relationships between each Lean tool and the selected key performance indicators (KPIs), following methodologies previously validated in similar industrial contexts [6].

A conceptual framework, as shown in Fig. 1, was developed to demonstrate how each component addresses a specific operational weakness. SMED reduces changeover times [6], Poka-Yoke mitigates human errors using low-cost visual aids [7], and Standard Work ensures process consistency across operators. Together, these elements form a coherent improvement model tailored to the semi-manual textile environment, directly contributing to a higher OTD performance rate and overall operational efficiency.

B. Experimental Procedure and Materials

The experimental phase of the study was conducted in the production area of a textile manufacturing company, focusing on operations involving industrial knitting machines, particularly during lot changeover procedures and the assembly of knitted fabric panels. These stages were selected due to their high frequency, direct impact on overall production efficiency, and their influence on the OTD performance. This process segment was suitable for experimentation given the observed variability in operator performance, recurrent setup delays, and the prevalence of human errors in raw material handling.

To implement the proposed improvements and collect the required data, the following materials and tools were used:

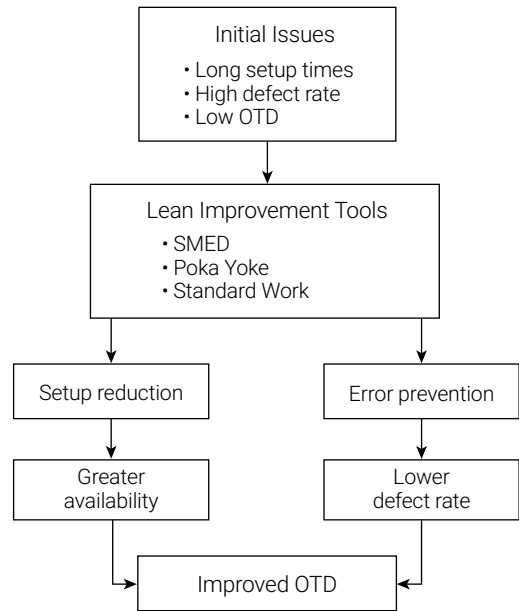

Fig. 1. Conceptual framework of the proposed improvement model.

- **Poka-Yoke device:** A low-cost error-proofing solution consisting of a phosphorescent visual ring installed at the yarn input area to facilitate the correct identification and placement of thread cones. This visual aid was designed to prevent common errors associated with color confusion or wrong selection of materials during the preparation stage.
- **Manual tracking instruments:** Time logs and defect control sheets were used to collect operational data for each batch. These tools enabled the measurement of setup durations, the number and types of defects encountered, and any deviations from standard procedures throughout the production cycle.
- **Arena simulation software:** Used to develop a digital model of both the current and improved production processes. The simulation environment enabled controlled experimentation with process variables, such as setup times, operator sequences, and queue behavior. It also allowed for the analysis of expected improvements under repeatable conditions through multiple replications.
- **Standardized work documentation:** As part of the intervention, visual instructions and standard operating procedures (SOPs) were established to formalize the optimized process. These documents outlined the correct sequence of tasks, time allocations, and quality control points, supporting operator consistency and reducing process variability.

The use of these experimental resources ensured a robust and repeatable framework for validating the effectiveness of the proposed improvement tools, both within the simulation environment and under real-world operational conditions.

C. General Procedure

- 1) *SMED*: The SMED methodology was applied as part of a broader strategy to reduce machine downtime by improving equipment availability. Setup activities were reorganized to complete preparatory tasks like cone positioning and program checks in advance, while cleaning routines were streamlined. In addition, a Poka-Yoke device enabled operators to detect potential issues prior to setup, thereby preventing unplanned stoppages.

Table I presents the classification of current setup and production activities performed on STOLL machines, distinguishing between internal and external tasks according to the SMED methodology. A total of fourteen activities were identified, most of which are executed while the machine is stopped (internal). This baseline classification served as the foundation for identifying improvement opportunities, especially by proposing the externalization of tasks such as cleaning, cone placement, and preliminary inspections, to minimize changeover time and increase equipment availability.

By applying the SMED methodology, setup activities were reorganized and partially externalized. Cleaning and cone handling were streamlined, the program upload sequence was standardized, and fabric inspection was incorporated into external preparation. As shown in Table II, these changes reduced the proportion of internal activities while maintaining critical operations under direct machine downtime control.

The implementation of these improvements resulted in a significant reduction in setup time and an improvement in equipment efficiency. As shown in Table III, the average setup time decreased from 15 to 10.5 min, machine availability increased from 83 to 90%, and the total production time per lot was reduced from 480 to 394 min.

- 2) *Poka-Yoke*: To address a critical source of avoidable downtime, a Poka-Yoke solution was developed as part of a broader component aimed at improving process reliability through early error detection. As illustrated in Fig. 2, a fluorescent ring was installed on the thread cones to serve as a visual control, enabling operators to verify correct installation before initiating the knitting process. This low-cost device functions as a preventive checkpoint, allowing corrective action before the absence

TABLE I
CLASSIFICATION OF SETUP ACTIVITIES

Activity	Current method		
	Time	Internal	External
Evaluate technical sheet	30 min	X	
Transfer and weigh yarn cones	10 min	X	
Paraffin yarn cones	10 min	X	
Cleaning of STOLL machines	25 min		X
Placing yarn cones on STOLL machines	15 min		X
Uploading the knitting program into STOLL machine	15 min		X
Inspection and mending of knitted panels	20 min		
Linking of pieces in the linker machine	5 min	X	
Garment finishing (including minor mending)	10 min	X	
Washing and drying of garments	20 min	X	
Steaming and ironing	15 min	X	
Final quality control of garments	10 min	X	
External audit in plant	5 min	X	
Packaging into boxes	5 min	X	

TABLE II
PROPOSAL METHOD OF SETUP ACTIVITIES

Description	Time	Operation	Inspection	Internal/ External
Cleaning of STOLL machines	20 min	X		I
Placing thread cones on STOLL machines	10 min	X		I
Uploading the knitting program into STOLL machine	5 min	X		I
Inspection of produced fabric panels	15 min		X	I



Fig. 2. Poka-Yoke device.

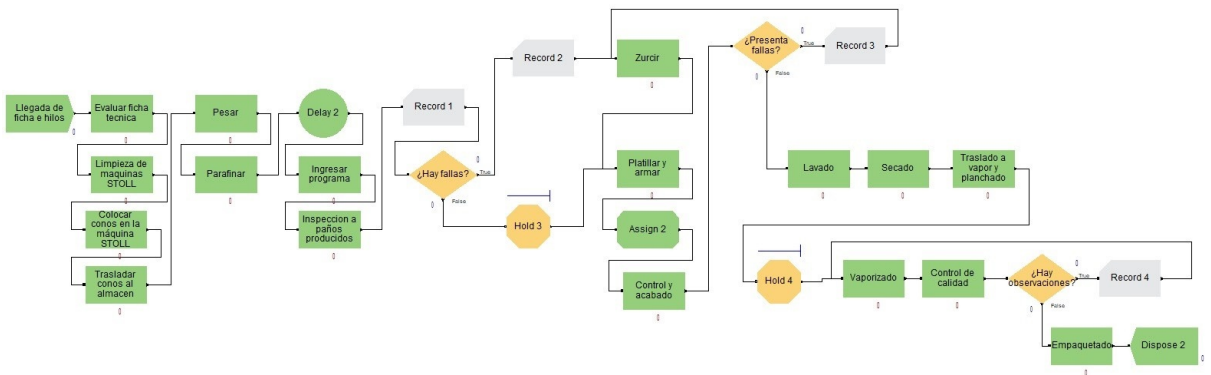

Fig. 3. Simulation model.

or misplacement of thread results in machine stoppages or defective output. As a result, the solution reduced the frequency of reactive stops and ensured that any necessary interventions occurred during planned setup time, contributing directly to overall time reduction, as shown in Table IV.

- 3) *Standard Work*: Standard Work was implemented as a targeted response to the high variability observed in operator-dependent tasks. Rather than being introduced in isolation, this tool was part of a broader component aimed at stabilizing process execution and ensuring repeatability. A standardized procedure was designed, outlining clear task sequences, time benchmarks, and visual checkpoints to guide operator actions. This structure enabled preventive control over deviations before they resulted in defects or delays. Through focused training and a structured pilot, operational consistency was achieved across shifts, reducing the coefficient of variation in task execution and eliminating procedural errors, as detailed in Table V.

D. Validation

To evaluate the effectiveness of the proposed improvement model, a simulation was carried out in Arena using 23 independent replications, ensuring statistical reliability across different operational scenarios. The number of replications was determined using a 95% confidence level (1.96), with a preliminary standard deviation of 1.2 min and a margin of error of ±0.5 min, as shown in (1).

$$n = \left(\frac{1.96 \times 1.2}{0.5} \right)^2 = (4.704)^2 = 22.13 \approx 23 \quad (1)$$

Key performance metrics such as average values and standard deviations were analyzed to assess changes in process times and defect rates before and after implementation.

TABLE III
SMED INDICATORS

Indicator	AS-IS	TO-BE
Average setup time (min)	15	10.5
Machine availability (%)	83%	90%
Total lot production time (min)	480	394

TABLE IV
POKA-YOKE INDICATORS

Indicator	AS-IS	TO-BE
Defect rate (%)	5%	2%
Errors detected per shift	10	4
Average error detection time (min)	12	3

TABLE V
STANDARD WORK INDICATORS

Indicator	AS-IS	TO-BE
Coefficient of variation in task time (%)	20%	10%
Errors from omitted steps (per shift)	3	0

Additionally, 95% confidence intervals were calculated for indicators including setup time, defect rate, total production time, and queue waiting time. These results enabled a robust comparison between AS-IS and TO-BE scenarios, confirming measurable improvements in process stability and operational efficiency.

Fig. 3 presents the Arena simulation model developed to replicate the improved process flow, highlighting the integrated SMED, Poka-Yoke, and Standard Work, as well as the quantitative results obtained through this validation framework.

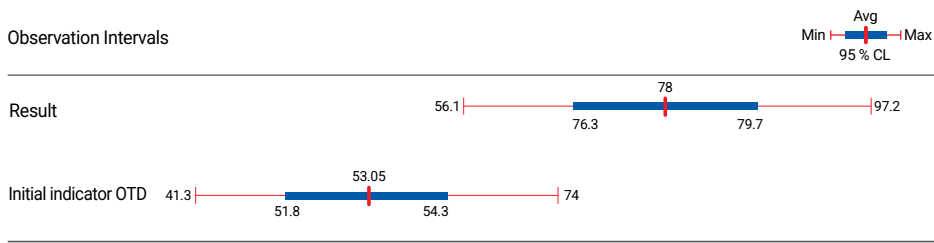

Fig. 4. Comparison of scenarios.

E. Population, Sample, and Research Variables

- Population: The cotton fabric manufacturing process in the company, specifically the STOLL machine area.
- Sample: Operational data collected from 23 simulation replications and on-site pilot tests conducted on the production floor.
- Main variables:
 - Dependent variable: OTD compliance rate (%).
 - Independent variables: Lot changeover time (min), defect rate (%).
 - Controlled variables: Operating conditions, number of operators, design of the Poka-Yoke device, standardized procedure.

III. RESULTS

A. Results From Arena Simulation

To validate the proposed improvement in a controlled environment, the current and improved production flows were modeled using Arena simulation software. The model represented the key activities of the textile process, from lot changeover to the final assembly of knitted fabrics. A total of 23 replications were executed to ensure statistical stability, using input data collected during the diagnostic phase.

As shown in Fig. 4, the Output Analyzer was used to evaluate the statistical significance of the improvement in OTD between the AS-IS and TO-BE scenarios. The analysis reports 95% confidence intervals for each scenario based on 23 simulation replications. Under the AS-IS condition, the average OTD was 53.05%, with a confidence interval ranging from approximately 51.8% to 54.3%. In contrast, the TO-BE scenario following the implementation of the proposed improvement model achieved an average OTD of 78%, with a corresponding interval between 76.3% and 79.7%.

The absence of overlap between the confidence intervals confirms that the observed improvement in OTD is statistically significant at the 95% confidence level. This finding reinforces the effectiveness of the integrated SMED,

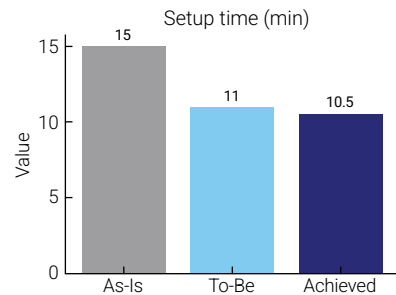

Fig. 5. Setup time results.

Poka-Yoke, and Standard Work tools in addressing the root causes of delivery delays and validates the robustness of the proposed model under variable operating conditions. The clear separation between the confidence intervals indicates a statistically significant improvement in delivery performance, confirming that the changes generated a real operational impact beyond random fluctuations.

B. Results From the Pilot Test

In parallel, a one-week physical pilot test was conducted on the actual production line. The proposed tools—SMED, Poka-Yoke, and Standard Work—were applied during a single production shift. Prior to implementation, operators received training, and standardized data collection forms were used to record real-time operational data.

The results were consistent with the simulation projections:

- 1) **SMED Results:** The application of SMED methodology enabled task separation and reclassification of internal and external activities. As a result, the average setup time was reduced from 15 to 10.5 min, while machine availability increased from 83% to 90%. In addition, the total production time decreased from 480 to 394 min, confirming the efficiency of the restructured setup process.
- 2) **Poka-Yoke Results:** The Poka-Yoke device, installed in the yarn cone input area, prevented cone misplacement and reduced operator-related errors. As shown

in Fig. 6, this low-cost visual aid contributed to a reduction in the defect rate from 5 to 2 %, while errors detected per shift decreased from 10 to 4. Moreover, the average error detection time improved from 12 to 3 min, confirming the effectiveness of the implemented solution. Together, Figs. 7 and 8 further illustrate how the error-proofing mechanism contributed to improved quality performance.

- 3) *Standard Work Results:* By establishing documented procedures, clear time benchmarks, and visual checkpoints, Standard Work ensured operator consistency. As shown in Fig. 9, the coefficient of variation in task execution time decreased from 20% to 10%, while the number of errors caused by omitted steps was reduced from 3 to 0 per shift. This outcome established a stable operational baseline, sustaining the improvements achieved through the implementation of SMED and Poka-Yoke.

In addition to these results, Fig. 10 illustrates the standardization of setup activities by comparing the AS-IS and TO-BE scenarios. Four critical tasks—machine cleaning, cone placement, program uploading, and fabric inspection—were reduced from a total of 75 to 50 min, representing a 33% improvement. This reduction was achieved by eliminating redundant steps, externalizing non-critical tasks, and applying standardized work instructions. The changes are supported by the time measurements collected during the pilot test and contrasted with baseline observations, confirming that the improvements are both measurable and repeatable under real production conditions.

C. Comparative Analysis of KPIs

Table VI summarizes the KPIs before and after the implementation of the proposed process improvements. The metrics clearly demonstrate the operational gains achieved in delivery performance, setup efficiency, defect reduction, and equipment availability, as shown in Table VI.

D. Baseline Performance Overview (AS-IS Scenario)

Prior to the implementation of the improvement model, the company showed a series of operational inefficiencies that directly affected overall performance. The OTD rate was 53.05 %, significantly below the textile industry benchmark of 77 %. The average setup time per changeover was 15 min, while machine availability was only 83%, indicating frequent delays and equipment downtime. In terms of quality, the defect rate reached 5%, primarily caused by manual setup errors such as incorrect cone positioning. Moreover, the coefficient of variation in operation time was 20%, reflecting inconsistencies in how operators performed tasks. The total production time per lot was 480 min, showing room for cycle time optimization.



Fig. 6. Poka-Yoke device implemented.

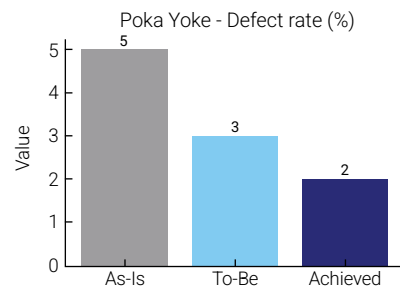

Fig.7. Defect rate (%) results.

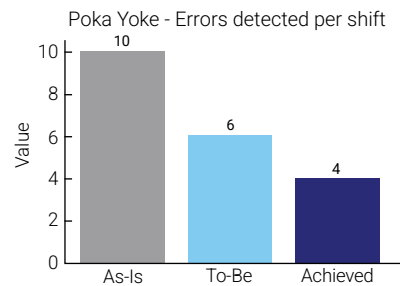

Fig. 8. Error detected per shift results.

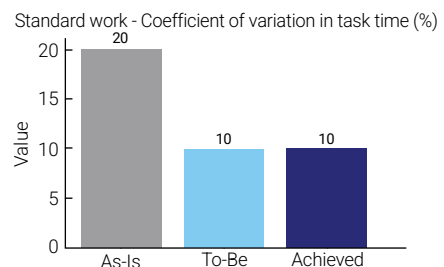

Fig. 9. Coefficient of variation in task time %.

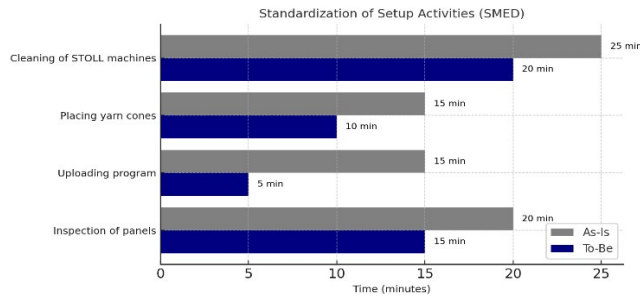

Fig. 10. Standardization of setup activities.

TABLE VI
KPIs

Indicator	Component (X)	Current situation (AS-IS)	Reference benchmark (TO-BE)	Result
OTD (%)	Y – Overall efficiency	53.05%	≥ 77% (textile sector)	77.9%
Average setup time (min)	X1 – SMED	15 min	≤ 11	10.5 min
% of defective products	X2 – Poka-Yoke	5%	≤ 3%	2%
Coefficient of variation in operation time	X3 – Standard Work	20%	≤ 10%	10%
Machine availability (%)	X4 – SMED	83%	≥ 90%	90%
Total production time per batch (min)	X5 – Combined result	480 min	---	394 min

E. Post-Implementation Results

The post-implementation values closely aligned with the expected targets. OTD increased to 78 %, meeting the industry reference. The average setup time was reduced to 10.5 min, while machine availability rose to 90%, fulfilling the primary objectives of the SMED methodology. The defect rate declined to 2%, confirming the effectiveness of the Poka-Yoke device in reducing human-related errors. In addition, the coefficient of variation in operation time decreased from 20 to 10%, validating the impact of Standard Work on process consistency. Finally, the total production time per lot was reduced from 480 to 394 min, demonstrating a substantial productivity improvement across the entire production cycle.

F. Strategic Implications and Long-Term Relevance

The outcomes of this improvement initiative confirm not only the technical soundness of the selected tools—SMED, Poka-Yoke, and Standard Work—but also their strategic potential for broader application within the organization. The successful increase of OTD from 53.05 to 78 % demonstrates a clear enhancement in the company’s ability to meet customer deadlines and contractual obligations, a critical factor for maintaining competitiveness in international textile markets. The reduction in lot

changeover time from 15 to 10.5 min, together with the increase in machine availability from 83 to 90%, indicates that production capacity and line responsiveness were significantly enhanced without the need for capital-intensive investments. Furthermore, the 60% decrease in the defect rate (from 5% to 2%) highlights the effectiveness of the visual control device in preventing operator error, thereby improving product quality and reducing rework.

These results were validated through 23 test runs, of which 17 met or exceeded the target performance levels, confirming the reliability of the proposed solution under real operating conditions. The remaining six runs exhibited slight deviations, primarily attributable to operational variability such as inconsistent thread cone setup or operator fatigue, highlighting the importance of continuous training and ergonomic improvements.

The replicability and low cost of the tools used, particularly the fluorescent ring implemented in the Poka-Yoke system, make them highly scalable across other machines and production lines. Future improvement cycles should focus on consolidating the current gains through real-time performance tracking such as e.g., visual management boards and structured operator feedback mechanisms. Additionally, standardization protocols developed during this phase can serve as templates for formal SOPs applicable across the plant. This approach positions the company to establish a

culture of continuous improvement, aligning daily operations with long-term operational excellence objectives.

IV. DISCUSSION

The validation results obtained through simulation and pilot testing confirm the effectiveness of the integrated improvement model composed of SMED, Poka-Yoke, and Standard Work in enhancing operational performance within a small-scale textile manufacturing environment. This section discusses the practical implications, interpretative insights, and strategic contributions derived from the findings.

A. Effectiveness of the Integrated Tools on KPIs

The combined application of the three Lean tools led to significant improvements in the main operational indicators, demonstrating both efficiency gains and defect prevention. Similar studies in the Peruvian textile sector have validated such approaches, confirming their suitability for SMEs with limited resources [5].

- OTD: Improved from 53.05% to 78%, a 24.95 percentage point increase. This change represents an operational shift from non-compliance with industry standards (77%) to performance alignment and competitiveness.
- Setup time: Reduced from an average of 15 to 10.5 min, achieving a 30% decrease in lot changeover duration, as validated both through pilot tracking and Arena simulation averages across 23 replications. This is in line with research that emphasizes the importance of SMED and Standardized Work in setup reduction strategies.
- Defect rate: Decreased from 5% to 2%, a 60% reduction, directly linked to the implementation of the Poka-Yoke device. This reduction minimized rework and raw material waste, as similarly demonstrated in studies analyzing Poka-Yoke in textile environments [7].
- Machine availability: Increased from 83% to 90%, translating to an approximate 7-point gain, due to fewer unplanned stops and more efficient operator interventions. These outcomes resonate with previous applications of Lean tools such as 5S and Kaizen for boosting availability and reliability in production lines [8].

These results validate the hypothesis that an integrated improvement model produces greater cumulative benefits than the isolated application of individual Lean tools. Similar integrated frameworks have shown consistent success in textile manufacturing by addressing inefficiencies holistically [9].

B. Interpretation of Simulation and Statistical Validation

The simulation in Arena provided a controlled environment to anticipate results before deployment. The Output Analyzer confirmed, with a 95% confidence level, that the projected OTD would reach the 78% threshold, with a mean difference of 24.95% compared to baseline.

The setup time distribution, modeled under a standard deviation of 1.2 min and a target margin of error of ± 0.5 min, yielded a reliable confidence interval, demonstrating statistical stability in the pilot design. This supports the notion that the sample of 23 replications was sufficient to reflect real-world variability without sacrificing confidence in the outcome. This methodological approach aligns with prior work combining Lean Manufacturing and simulation to validate performance improvements in SMEs [10].

C. Organizational and Practical Implications

Beyond quantitative outcomes, the intervention revealed important organizational dynamics. The standardization of work instructions enabled faster onboarding and greater consistency across shifts, reducing dependence on individual expertise. Visual cues and task sequencing provided operators with greater autonomy and fewer decision points, contributing to a reduced cognitive load.

Operator feedback during the pilot phase indicated higher satisfaction, clearer expectations, and reduced ambiguity during setup. This outcome is particularly critical for small enterprises with high employee turnover or limited training resources. These results confirm that Lean practices can be successfully adapted to SMEs even with low technological complexity, as demonstrated in similar analyses of Lean systems within the textile industry [11]. The key lies in properly tailoring the solution to the context and involving the production team in co-designing the changes. Moreover, foundational Lean concepts such as error-proofing have proven to be both accessible and effective in enhancing quality standards [12].

D. Strategic and Academic Contribution

The study provides an evidence-based model for productivity improvement that is low-cost, replicable, and sustainable, particularly relevant for textile SMEs in Latin America. The data demonstrate that meaningful performance improvements can be achieved with minimal investment by focusing on process discipline, visual management, and task segmentation. Additionally, the research contributes methodologically by integrating field experimentation with simulation modeling, thereby reinforcing both academic rigor and practical relevance. Similar proposals have also highlighted the scalability of such interventions in emerging economies [13].

Recent studies have confirmed that Lean Manufacturing models tailored to small-scale textile operations can lead to significant improvements in quality and delivery efficiency

when supported by structured supplier involvement and low-cost automation [14]. Moreover, initiatives such as Lean Synergy and data-driven frameworks are emerging as promising alternatives for micro and small enterprises seeking to transition from informal practices toward standardized production systems [15]. These contributions reinforce the idea that contextual adaptation and team involvement are critical to sustaining long-term improvements in resource-constrained environments.

E. Limitations and Future Research Directions

Although the proposed improvement model demonstrated significant performance gains, certain limitations remain that open avenues for future research:

- The model was applied to a specific operating production context with relatively stable conditions. Its adaptability to more dynamic environments characterized with fluctuating demand or multi-line operations requires further exploration. Studies focused on flexible implementations of Lean in multi-product settings could provide useful insights in this regard [15].
- The interaction between the tools was validated sequentially. Future studies may explore simultaneous or iterative deployment strategies to enhance scalability and responsiveness. Hybrid approaches—such as combining Lean tools with supplier performance monitoring or data-driven feedback loops, as proposed in recent literature—offer promising directions [16].
- Lastly, the model focuses on operational metrics. Extending the framework to incorporate sustainability, energy efficiency, or digital integration (e.g., IoT-enabled monitoring) would provide a more holistic perspective for long-term competitiveness. Research exploring Lean frameworks that integrates with environmental and technological dimensions, such as the models proposed by Huayra-Mendoza and Ticlavlilca-Arias [17], represents a relevant frontier for future exploration.

V. CONCLUSION

This study demonstrated that the integrated application of SMED, Poka-Yoke, and Standard Work can significantly improve production performance in a textile SME operating under limited resources. The model addressed critical operational inefficiencies—such as excessive setup time, high defect rates, and operator variability—through practical, low-cost solutions.

As a result, OTD increased from 53.05% to 78%, setup time was reduced by 30%, machine availability increased to 90%, and the defect rate dropped from 5% to 2%. These improvements were validated through both simulation

and pilot testing, confirming the model's effectiveness and statistical significance. The findings highlight the potential of tailored Lean tools to generate impactful results in small-scale manufacturing. Beyond performance gains, the approach supports standardization, enhances operator consistency, and sets a foundation for continuous improvement, making it a scalable solution for SMEs seeking greater efficiency and competitiveness.

REFERENCES

- [1] Ministerio de la Producción. *Sector textil y confecciones. Estudio de investigación sectorial 2020*. Lima, Perú, 2022.
- [2] A. Palange and P. Dhattrak, "Lean manufacturing a vital tool to enhance productivity in manufacturing," *Mater. Today: Proc.*, vol. 46, no. 1, pp. 729–736, Jan. 2021, doi: 10.1016/j.matpr.2020.12.193.
- [3] S. Sanchez, L. Sanchez, and G. Viacava, "Proposal to improve the dyeing process applying preventive maintenance, SMED and standardization in an industrial dry cleaner," in *Proc. ICIBE '22: 8th Int. Conf. Ind. Bus. Eng.*, Jan. 2023, pp. 426–430, doi: 10.1145/3568834.3568887.
- [4] K. Paździor, L. Bilińska, and S. Ledakowicz, "A review of the existing and emerging technologies in the combination of AOPs and biological processes in industrial textile wastewater treatment," *Chem. Eng. J.*, vol. 376, p. 120597, Nov. 2019, doi: 10.1016/j.cej.2018.12.057.
- [5] M. Torres-Mestanza, N. Guerrero-López, and M. Saenz-Moron, "Improvement model to increase the efficiency of the sewing area in a textile SME by applying SMED, 5S and Standardized Work – A Peruvian case study," in *Proc. 21st LACCEI Int. Multi-Conf. Eng., Educ., Technol.*, Jan. 2023, doi: 10.18687/laccei2023.1.1.1051.
- [6] A. Deshkar, S. Kamle, J. Giri, and V. Korde, "Design and evaluation of a Lean Manufacturing framework using Value Stream Mapping (VSM) for a plastic bag manufacturing unit," *Mater. Today: Proc.*, vol. 5, no. 2, pp. 7668–7677, Jan. 2018, doi: 10.1016/j.matpr.2017.11.442.
- [7] J. Yashini, "An analysis on minimization of product error (Poka-Yoke) and excess work in progress (TPM & OEE) in textile industry," *Int. J. Res. Eng., Sci. Manag.*, vol. 3, no. 9, pp. 17–22, Sep. 2020, doi: 10.47607/ijresm.2020.278.
- [8] E. A. Demirtas, O. S. Gultekin, and C. Uskup, "A case study for surgical mask production during the COVID-19 pandemic: Continuous improvement with Kaizen and 5S applications," *Int. J. Lean Six Sigma*, vol. 14, no. 3, pp. 679–703, Dec. 2022, doi: 10.1108/IJLSS-02-2022-0025.

- [9] M. Mohan Prasad, J. M. Dhiyaneswari, J. R. Jamaan, S. Mythreyan, and S. M. Sutharsan, "A framework for Lean Manufacturing implementation in Indian textile industry," *Mater. Today: Proc.*, vol. 33, no. 7, pp. 2986–2995, Mar. 2020, doi: 10.1016/j.matpr.2020.02.979.
- [10] J. A. Dominguez Julca, E. A. Algendones Amasifuen, and R. Chavez-Ugaz, "Improvement proposal to increase the level of service by applying Lean Manufacturing tools in SMEs in the textile sector in Peru," in *Proc. Congr. Int. Innov. Tend. Ing. (CONIITI)*, Oct. 2024, pp. 1–7, doi: 10.1109/CONIITI64189.2024.10854859.
- [11] C. Ünal and S. Bilget, "Examination of Lean Manufacturing systems by simulation technique in apparel industry," *J. Text. Inst.*, vol. 112, no. 3, pp. 377–387, Apr. 2020, doi: 10.1080/00405000.2020.1756104.
- [12] H. Hirano, *Poka-Yoke: Improving Product Quality by Preventing Defects*, 1st ed. Portland, OR, USA: Productivity Press, 1989.
- [13] A. Quiroz-Cueva, M. Simbrón-Guillen, and M. Saenz-Moron, "Improvement proposal to increase the production efficiency of garment with Lean Manufacturing tools for the textile sector in Lima," in *Proc. 21st LACCEI Int. Multi-Conf. Eng., Educ., Technol.*, Jan. 2023, doi: 10.18687/laccei2023.1.1.1045.
- [14] G. C. Alcazar-Quispe and M. P. Acuña-Ordóñez, "Enhancing operational efficiency in textile SMEs: A Lean Manufacturing approach integrating Poka-Yoke and supplier management," in *Proc. 5th Asia-Pac. Conf. Ind. Eng. Oper. Manag.*, Sep. 2024, doi: 10.46254/ap05.20240089.
- [15] V. Y. Valverde-Flores, B. J. Toribio-Alvarado, M. Collao Diaz, and J.-C. Quiroz-Flores, "Lean Synergy production model implementation in textile SMEs: A case study on efficiency and quality improvement," in *Proc. 3rd Aust. Conf. Ind. Eng. Oper. Manag.*, Sep. 2024, doi: 10.46254/AU03.20240075.
- [16] S. Tejada, S. Valdez, O. Yildiz, R. Salas-Castro, and J. C. Alvarez, "A data-driven Lean Manufacturing framework for enhancing productivity in textile micro-enterprises," *Sustainability*, vol. 17, no. 11, p. 5207, Jun. 2025, doi: 10.3390/su17115207.
- [17] G. F. Huayra-Mendoza and K. C. Ticlavilca-Arias, "Comprehensive Lean production model implementation for quality and efficiency enhancement in textile SMEs: A case study," in *Proc. 1st World Congr. Ind. Eng. Oper. Manag.*, Oct. 2024, doi: 10.46254/WC01.20240041.

BIOGRAPHICAL NOTES

PAUL MARTIN YAURI-ARTICA

Paul Martin Yauri-Artica holds a Bachelor's degree in Industrial Engineering from Universidad de Lima, Peru, with a specialization in Business Engineering. He currently works as a Business Specialist at Pacifico Seguros, where he is part of the business division and manages mass-market products across bancassurance and strategic alliance channels. He works with strategic partners including Peru's leading bank, Latin America's leading e-commerce platform, and the country's most widely used digital wallet, contributing to the development, monitoring, and optimization of products aimed at protecting millions of Peruvians and generating business profitability. He has experience in digital transformation and digital growth, with a focus on optimizing time and resources, enhancing the digital customer experience, and driving the digitalization of processes and sales, as well as in the leadership and management of strategic initiatives in corporate environments. His areas of interest include business management, process improvement, digital transformation, and resource optimization.

NICOL CRISTINA MELGAR-BARRIOS

Nicol Cristina Melgar-Barrios holds a Bachelor's degree in Industrial Engineering from Universidad de Lima, Peru. She currently works as a Business Specialist at Banco de Crédito del Perú (BCP), where she supports the deployment of commercial campaigns across sales channels and conducts market share and data analysis for the Cuenta Sueldo product, as well as projects targeting corporate and individual clients to support business decision-making. She has professional experience in administrative management, customer communication, quotation handling, and payment control, which has strengthened her understanding of operational and service-oriented processes. Her academic and professional interests focus on process improvement, lean manufacturing tools, operational efficiency, and data analysis applied to business contexts.

GINO VIACAVA-CAMPOS

Gino Viacava-Campos holds a Master's degree in Operations and Logistics from Universidad Peruana de Ciencias Aplicadas, Peru, and a degree in Industrial Engineering from Universidad de Lima, Peru. He is currently a professor in the Industrial Engineering Program at Universidad de Lima. He has experience in industrial and service companies, focusing on productivity improvement, business model development, and compensation system structuring. He has worked in human resources, operations, and logistics areas of a transnational company, both locally and overseas. As a consultant, he has experience in the construction, manufacturing, services, mining, commercial, finance, and education sectors. He has co-authored papers including "A Production Process Efficiency Improvement Model at

a MSME Peruvian Metalworking Company,” published in the Proceedings of the 2022 IEEE International Conference on Industrial Engineering and Engineering Management (IEEM). His main research interests are lean manufacturing, master production schedules, logistics, and compensation systems for small and medium-sized enterprises.

JORGE ANTONIO CORZO-CHAVEZ

Jorge Antonio Corzo-Chavez holds a Master's degree in Business Administration from Universidad ESAN, Peru; a Master's degree in Marketing Science from ESIC Business & Marketing School, Spain; and a degree in Industrial Engineering from Universidad de Lima, Peru. He is currently a professor in the Industrial Engineering Program at Universidad de Lima and Chief Executive Officer at Conquista Lab. He has advised industrial and service companies on productivity improvement and business model

development, and has worked in entrepreneurship, innovation, and commercial roles in the construction, mining, services, and education sectors. He has co-authored papers including “Improvement of Productivity by Applying 5S, Work Standardization, Ergonomic Analysis and Poka Yoke in a Metalworking Company,” published in the Proceedings of the 23rd LACCEI International Multi-Conference for Engineering, Education, and Technology; “Production Model Based on Lean Manufacturing and Systematic Layout Planning to Reduce Waste in a Company in the Poultry Sector: A Case Study,” published in the International Journal of Environmental Pollution and Remediation, volume 12; and “Model for Reducing Mean Absolute Percentage Error through Smoothing and Time Series Forecasting in a Tourism SME: A Case Study,” published in the Journal of Machine Intelligence and Data Science, volume 5. His main research interests are lean manufacturing, logistics, and machine learning for enterprises.

Improvement of Outbound Logistics in an E-Commerce Company Using RPA, ABC Analysis, and SLP Tools

Elizabeth S. Castillo Vera¹ , Gian P. F. Robles Flores² , José A. Taquía Gutiérrez³ ,

María T. Noriega Aranibar de Lavalle⁴ 

¹20200461@aloe.ulima.edu.pe, ²20201797@aloe.ulima.edu.pe, ³jtaquia@ulima.edu.pe, ⁴manorieg@ulima.edu.pe

¹²³⁴Carrera de Ingeniería Industrial, Universidad de Lima, Perú

Received: August 1, 2025 / Accepted: September 23, 2025 / Published: 5 June, 2026

doi: <https://doi.org/10.26439/ciii2025.8650>

ABSTRACT—This study aims to reduce the high percentage rate of failed deliveries (39.09%) in a Peruvian import-based e-commerce company, whose operations exhibit deficiencies in distribution and storage processes. To address these issues, an integrated solution was designed using three logistics tools: the systematic layout planning (SLP) methodology, employed to reorganize the warehouse according to nine product categories; ABC classification, used to relocate items within racks based on their turnover and demand; and robotic process automation (RPA), applied to routing through optimization algorithms. The proposal complied with current technical and legal regulations and was validated through simulation using Arena software, demonstrating an 83.6% reduction in routing time, a 54.6% improvement in average picking time, and a 20-percentage-point increase in the on-time in-full (OTIF) indicator. The results confirm that the integrated application of these tools significantly improves logistics efficiency in similar operational models within the e-commerce sector.

Index Terms—ABC classification, e-commerce, outbound logistics, robotic process automation, systematic layout planning.

I. INTRODUCTION

In Peru, e-commerce has become a key sales channel for small- and medium-sized enterprises, with sustained growth projected through 2025, particularly in the retail sector [1]. This growth has been driven by widespread internet access, which exceeds 90% in urban areas, significantly accelerating the expansion of digital commerce in the country [2]. Moreover, the evolution of the digital ecosystem has introduced new payment methods, such as mobile wallets, which have gained prominence and influenced both the average purchase value and purchase frequency [3].

However, this growth presents significant logistical challenges. Ensuring effective delivery fulfillment remains one of the main operational hurdles in the sector. According to Gonzales [4], 7.4% of orders fail to be completed each month, resulting in additional costs, customer dissatisfaction, and rework. The average on-time in-full (OTIF) rate in e-commerce operations ranges from 82% to 90%, according to studies on logistics performance in emerging markets [5], indicating that 10% to 18% of deliveries encounter issues. Operationally, the average picking time in e-commerce warehouses ranges between 10 and 16 min per order [6], while urban route planning may take between 30 and 60 minutes, depending on congestion levels and logistics coverage [7]. Additionally, workforce utilization in e-commerce warehouses ranges from 65% to 85%, according to operational efficiency studies [6].

This proposal aims to reduce the percentage of failed deliveries, improve the OTIF indicator, and optimize picking and distribution times, ensuring a more efficient, scalable, and industry-aligned logistics flow.

Robotic process automation (RPA) has proven to be an effective tool for optimizing logistics activities in digital environments. Smith [10] demonstrated that implementing RPA improves the coordination of key activities such as inventory management and order processing, while reducing manual errors and accelerating operational cycles. Ramingwong *et al.* [11] reported an average 22.3% reduction in logistics costs and improvements in traceability and delivery compliance following process automation. Aguirre and Rodríguez [12] reported a 21% increase in productivity in service and dispatch processes using RPA, without compromising service times. Pasupuleti [13] highlighted that RPA is particularly effective in critical environments, such as hospital and e-commerce logistics, where automating repetitive tasks enhances operational efficiency, reduces human error, and ensures consistency

in key processes such as dispatch and planning, all without disrupting service continuity. Finally, Kitsantas *et al.* [14] highlighted that integrating RPA with artificial intelligence not only automates repetitive tasks but also enables real-time autonomous decision-making, enhancing operational resilience and responsiveness—key aspects of digital distribution platforms. These findings further support the positive impact of RPA on efficiency, accuracy, and compliance indicators in modern logistics operations.

Regarding layout optimization in logistics and e-commerce environments, multiple studies support the effectiveness of systematic layout planning (SLP) in improving operational performance. Hu and Chuang [15] applied SLP combined with a genetic algorithm to redesign an e-commerce warehouse in China, achieving a 27.72% reduction in handling costs and a 39.25% improvement in picking efficiency. Valdivia *et al.* [16] implemented SLP in combination with Lean methodologies in a spare parts warehouse in Metropolitan Lima, resulting in a 23% reduction in picking distance and a 22% improvement in OTIF compliance. Similarly, Ramírez-Cruz *et al.* [17] applied SLP in a pharmaceutical warehouse, reducing order effort by 45% and cycle time by 42%, which led to a decrease in picking errors by over 4 percentage points. Likewise, Badharinath *et al.* [18] demonstrated that applying SLP reduced travel distance on the production floor by 34.9% and doubled output in a mechanical component factory. Finally, Marcelo-Alfaro *et al.* [19] implemented SLP in a Peruvian small logistics warehouse, reducing product search time by 61.5% and improving shelf space utilization by 10.06%, while also validating a positive impact on delivery performance.

Regarding ABC classification, recent studies support its integration with layout design to improve warehouse performance, especially when adapted to product turnover and demand. Avdeikins and Savrasovs [20] highlight the strategic placement of products to reduce labor costs and increase picking efficiency. Gonzales-Vasquez *et al.* [21] analyzed warehouse inventory management using ABC slotting, achieving a 43.79% increase in productivity, a 65% improvement in operational efficiency, and, most importantly, a 6.2% reduction in erroneous product returns. Flores *et al.* [22] applied ABC classification based on sales volume, improving warehouse key performance indicators (KPIs) by increasing turnover and reducing storage time. Enhanced organization also contributed to shorter picking process times. Özhan *et al.* [23] reported that ABC analysis increased the efficiency of merchandise reception and dispatch processes by 20% and improved shelf space utilization by 30%. Finally, Silva *et al.* [24] stated that ABC classification represents the most widely used policy for addressing storage location allocation problems.

Lastly, process simulation using specialized software such as Arena has been validated in multiple studies for its ability to model scenarios without disrupting real operations. Research by Valdivia *et al.* [16], Ramírez-Cruz *et al.* [17], and Pasupuleti [13] used Arena to model and compare scenarios before and after implementing the proposed tools.

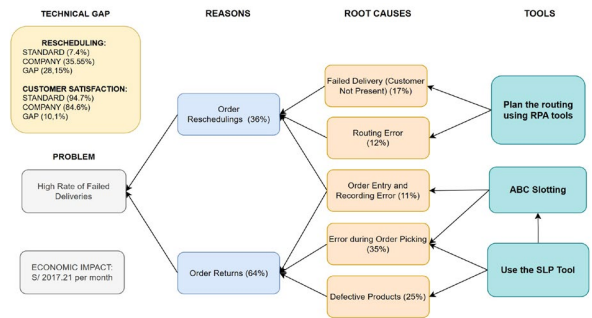

Fig. 1. Problem tree.

II. METHODOLOGY

This study corresponds to an applied research project, with a quantitative approach and experimental design, and an explanatory scope. The unit of analysis is the company's outbound order process, encompassing the picking, packing, and delivery routing activities for customers in Metropolitan Lima. Given that the company handles a broad portfolio distributed across nine categories, the universe of analysis was defined as the set of daily orders containing products from the five highest-volume categories: home, bags and purses, car accessories, jewelry and accessories, and fashion accessories.

The company under study is a Peruvian e-commerce firm specializing in the import and sale of stationery, home goods, and personal care products, among others. It currently manages a catalog of 581 stock keeping units (SKUs), with an average purchase value of S/164 and a monthly average of 6,799 orders. Sales are conducted through digital platforms and social media channels, complemented by cash-on-delivery services to enhance customer trust. However, this modality introduces significant operational risks, as it does not ensure sales confirmation prior to dispatch, leading to costly order cancellations and rescheduling. During the most recently evaluated quarter, the company reported a failed delivery rate of 39.09%, a rescheduling rate of 35.55%, and an on-time in-full (OTIF) performance of only 60.91%, substantially below the industry benchmark of 86% [5].

The comparative analysis between the company's KPIs and e-commerce sector benchmarks, as shown in Fig. 1 (Problem Tree), reveals significant technical gaps. In particular, a 28.15% deviation in rescheduled failed deliveries relative to the national average of 7.4% [4] indicates structural deficiencies in the company's outbound logistics processes. Regarding customer experience, the recorded satisfaction rate of 84.6% is 10.1 percentage points below the benchmark of over 94% [8]. In addition, the company operates with a storage density of 1,592 units/m², which significantly exceeds the recommended range of 300 to 800 units/m² established by logistics design standards [9], contributing to physical disorder, picking errors, and

MACRO DESIGN OF THE STUDY

DEVELOPMENT TOOLS

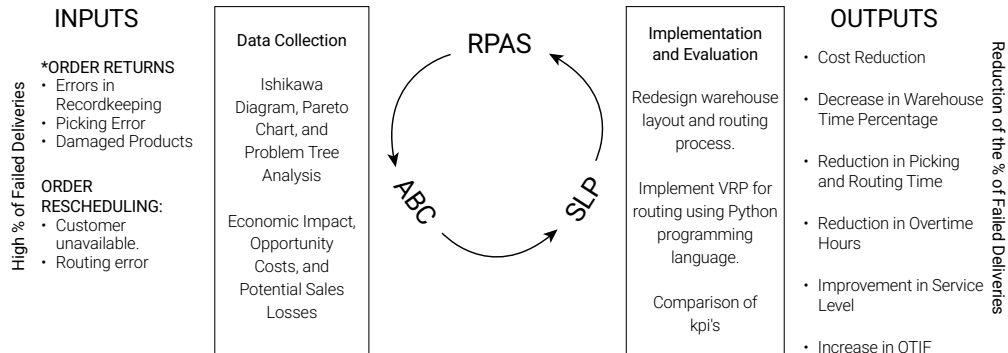

Fig. 2. Macro design of the study.

congestion in the layout. One of the most critical issues lies in routing time, which currently ranges between 60 and 90 min per batch, exceeding the estimated 30 to 60-min average for Metropolitan Lima [7], by up to 30 min. This situation directly affects service levels, increases logistics costs, and jeopardizes the company's operational sustainability.

On average, the company processes 250 daily orders, of which 80.5% correspond to the five main categories, resulting in an effective population of 201 orders. To estimate the sample size, the classical formula for finite populations was used with a 95% confidence level, an expected proportion of 5%, and a 5% margin of error, resulting in a sample size of 54 orders. These were selected using non-probabilistic convenience sampling, comprising the first 54 orders that contained at least one product from the five main categories.

Regarding the macro-level design (Fig. 2), the system was structured into three main blocks: inputs, processes, and outputs. The input block included generated orders, current product locations, route assignments, and category-based demand. The process block comprised picking, packing, and route assignment operations. The evaluated outputs included picking time ($T_{picking}$), routing time, picking and packing personnel utilization rate, failed delivery rate, and the on-time in-full (OTIF) indicator, whose formulation is presented in (1).

$$OTIF = \frac{\text{Orders delivered on time and in full}}{\text{Total orders}} \times 100 \quad (1)$$

The TPICKING indicator was defined as the average time, expressed in minutes, required to collect the products associated with an order. This metric was measured using direct time studies.

To structure the improvement proposal, three complementary tools were used:

- **RPA** applied to delivery route planning, automating route generation using optimization algorithms

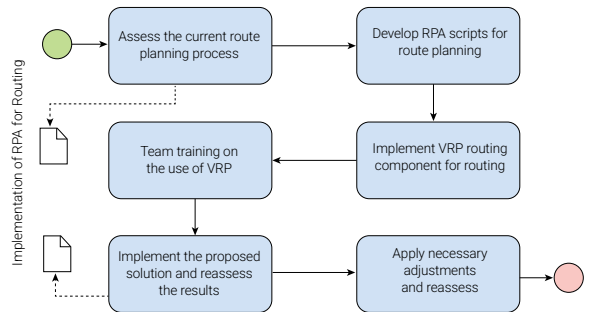

Fig. 3. Bizagi, implementation of RPA.

based on the vehicle routing problem (VRP), coded in Python

- **SLP** used to reorganize the warehouse layout based on proximity relationships, interaction frequency, and physical constraints
- **ABC classification** applied to relocate products within the warehouse according to their turnover and demand, maximizing accessibility for high-frequency items

Given that the company was unable to implement major structural changes due to regulatory, spatial, and budgetary constraints, the proposed improvements were validated through simulation. This approach enabled the modeling and comparison of both the current and proposed systems using Arena simulation software.

III. RESULTS

First, an automated routing system was developed following the steps shown in Fig. 3, using the UiPath Community version platform (Fig. 6) integrating Python

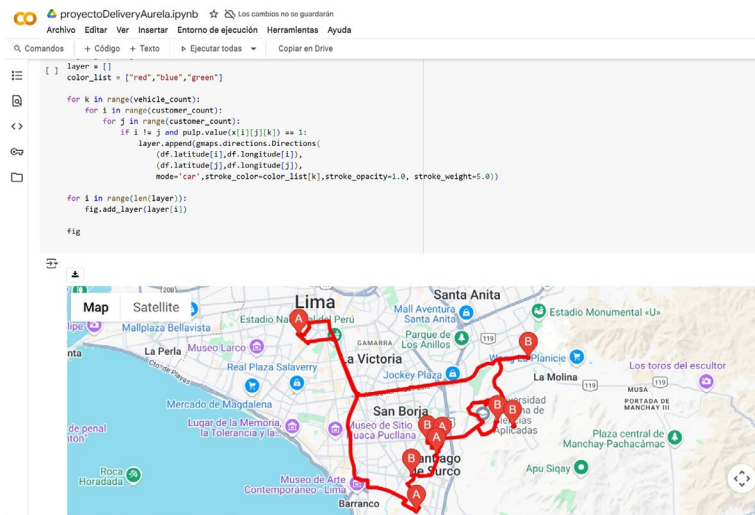

Fig. 4. Route designed using VRP in Google Maps.

START

1. **Import necessary libraries:** PuLP, Google Maps API, pandas, matplotlib, etc.
2. **Define problem parameters:**
 - Number of clients (n)
 - Number of vehicles (m)
 - Capacity of each vehicle (Q)
 - Warehouse coordinates
 - Read Excel file with coordinates and demand of each client
3. **Set node 0 as the depot:**
 - Replace row 0 with warehouse coordinates and demand = 0
4. **Calculate the distance matrix:**
 - Use Google Maps Directions API to get real distances between each pair (i, j)
5. **Create optimization model in PuLP:**
 - Binary variables $x[i][j][k] = 1$ if vehicle k goes from i to j
 - Objective function: minimize the total distance traveled
6. **Add constraints:**
 - Each client must be served only once
 - Each vehicle must leave and return to the depot
 - Flow conservation at all nodes (inputs = outputs)
 - Total demand per route must not exceed capacity Q
 - Eliminate sub-tours with additional constraints
7. **Solve the model:**
 - If a feasible solution is found, print the minimum distance and assigned routes
8. **Visualize results:**
 - Show node locations (warehouse and clients) on a map
 - Draw optimal routes between connected points

END

Fig. 5. Pseudocode for route generation using RPA.

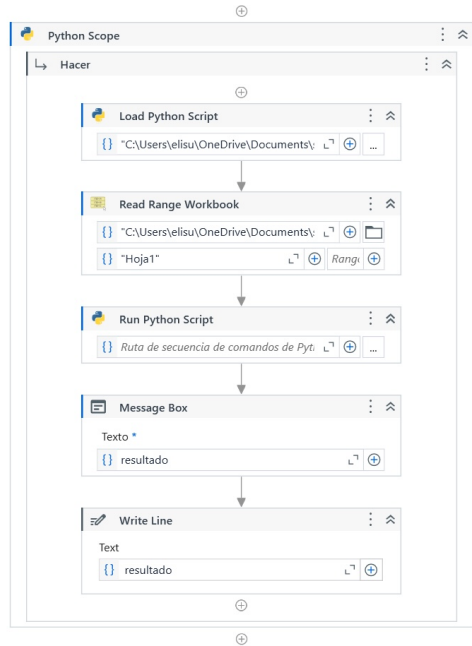

Fig. 6. UiPath programming.

programming to execute a vehicle routing problem (VRP)-based optimization algorithm.

A routing optimization algorithm with capacity constraints was developed using real operational data obtained through the Google Maps application programming interface (API), as shown in Fig. 4. The model was built in Python using integer linear programming and supported by libraries such as PuLP, pandas, matplotlib, and the Google Maps API. The model integrates demand

information, geographic coordinates, and vehicle capacity constraints. Fig. 5 presents the pseudocode that describes the general structure and operational logic of the proposed algorithm.

This system replaced the manual route planning process—which required an average of 73.8 min per day—with an automated approach that reduced the time to 12.13 min, representing an improvement of 83.6%. This reduction was calculated by multiplying the total algorithm execution

heights for easy access; medium-turnover items (Category B) were positioned at intermediate levels; and low-turnover items (Category C) were stored on the upper or lower levels, depending on demand. This reorganization optimized picking routes and improved inventory visibility without altering the overall layout logic established through SLP methodology.

Table I and Fig. 11 present the turnover percentages for each category along with their cumulative percentages. Additionally, the corresponding ABC classification is indicated.

To simulate the implementation of the proposed improvement and enable a comparative analysis with the initial situation, both scenarios were modeled in Arena, as illustrated in Fig. 12. Notably, no activities were added or removed in the improved scenario; instead, the processing times of specific Process modules—such as Picking and Route Assembly—were adjusted to reflect the proposed changes. The comparison between scenarios in Arena yielded the key results presented in Table II.

These results, validated through 42 replications with a 95% confidence interval, confirm that the proposal led to substantial improvements in operational efficiency, delivery timeliness, and human resource utilization. The progressive integration of RPA, SLP, and ABC slotting—with targeted application within the layout—proved to be a robust, replicable, and compatible solution for high-volume, space-constrained logistics operations.

IV. DISCUSSION

The results obtained from the Arena simulation validate the positive impact of the integrated proposal based on RPA, SLP, and ABC classification on key logistics performance indicators. The observed improvements—namely, a reduction of over 80% in routing time, a 20-percent-age-point increase in the OTIF indicator, and improved personnel utilization—are consistent with findings reported in previous studies that evaluated similar tools in e-commerce, manufacturing, and distribution environments.

Regarding routing automation via RPA, this study achieved a reduction in daily route planning time from 73.8 to 12.13 min, representing an 83.58% improvement. This result exceeds the 30% reduction by Ramingwong *et al.* [11], who implemented automation tools in manufacturing firms in Thailand. This transformation not only reduced the operational workload on personnel but also enhanced service timeliness and consistency.

Regarding warehouse layout redesign using SLP, prior studies—such as those by Ramírez-Cruz *et al.* [17] and Marcelo-Alfaro *et al.* [19]—have reported significant improvements in operational efficiency after reorganizing warehouses based on proximity, flow, and frequency criteria. In the present study, the application of SLP reduced

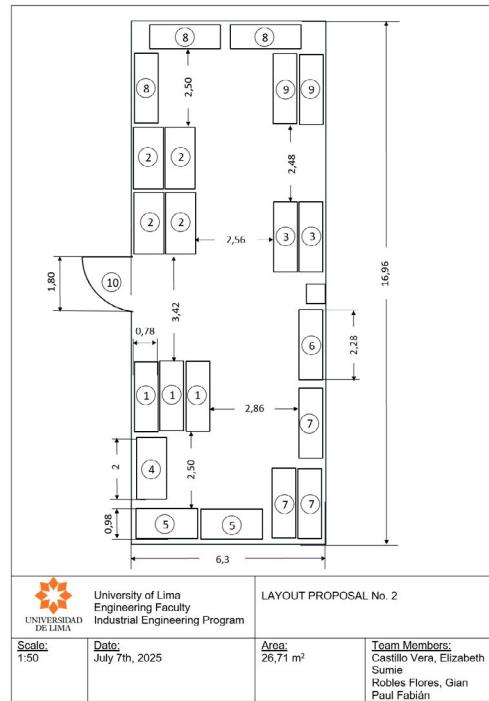

Fig. 10. Winning proposal for the warehouse layout redesign.

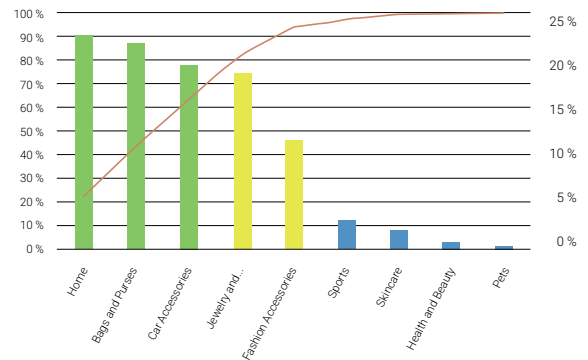

Fig. 11. Category classification chart based on inventory turnover.

TABLE I
CHART OF CATEGORY CLASSIFICATION BY TURNOVER

Category	Rotation %	Cumulative %	Category classification
Home	22.56%	22.56%	A
Bags and purses	21.73%	44.29%	A
Car accessories	19.43%	63.72%	A
Jewelry and accessories	18.5%	82.22%	B
Fashion accessories	11.47%	93.69%	B
Sports	3.06%	96.75%	C
Skincare	2.14%	98.89%	C
Health and beauty	0.82%	99.71%	C
Pets	0.29%	100%	C

operational performance, demonstrating that the synergy between digital and physical tools is key to transforming logistics processes in e-commerce contexts.

REFERENCES

- [1] L. M. Acuña Morales, P. M. Chávarry Pajuelo, R. A. Luna Huamanjulca, and J. J. Sánchez Reyes, "Gestión de innovación y tecnología en el sector e-commerce en el Perú [Innovation and technology management in the e-commerce sector in Peru]," *M.S. thesis*, Pontificia Universidad Católica del Perú, Lima, Peru, 2021. [Online]. Available: <https://www.proquest.com/openview/9ef01c7e8788550a20e16f48a2d85743/1>
- [2] M. A. Ortiz-Chávez, J. E. Mendoza-Pumapillo, J. O. Dilas-Jiménez, and C. A. Mugruza-Vassallo, "E-commerce of Peruvian SMEs: Determinants of internet sales before and during COVID-19," *Heliyon*, vol. 10, no. 23, Dec. 2024, doi: <https://doi.org/10.1016/j.heliyon.2024.e40331>
- [3] Banco Central de Reserva del Perú, "Reporte del Sistema Nacional de Pagos y del sector fintech en Perú - Marzo 2025 (Report on the National Payment System and the fintech sector in Peru - March 2025)," Banco Central de Reserva del Perú, Lima, Peru, 2025. [Online]. Available: <https://www.bcrp.gob.pe/docs/sistema-de-pagos/reportes/2025/informe-sistema-de-pagos-y-fintech-2025-1.pdf>
- [4] C. A. Gonzales Ruiz, "Propuesta de mejora de la gestión logística para cumplir con el nivel de servicio en un operador logístico [Proposal to improve logistics management to meet the service level in a logistics operator]," *Thesis for the degree of Industrial Engineer*, Universidad Nacional Mayor de San Marcos, Lima, Peru, 2021. [Online]. Available: <https://cybertesis.unmsm.edu.pe/backend/api/core/bitstreams/5918cb6d-bbb8-46fa-a09f-f754a73cb823/content>
- [5] S. Chopra, *Supply chain management: Strategy, planning, and operation*, 7th ed. Harlow, U.K.: Pearson, 2021.
- [6] E. H. Grosse, C. H. Glock, M. Y. Jaber, and W. P. Neumann, "Incorporating human factors in order picking planning models: Framework and research opportunities," *Int. J. Prod. Res.*, vol. 53, no. 3, pp. 695–717, 2015, doi: <https://doi.org/10.1080/00207543.2014.919424>
- [7] Y. Wang, L. Ran, X. Guan, J. Fan, Y. Sun, and H. Wang, "Collaborative multicenter vehicle routing problem with time windows and mixed deliveries and pickups," *Expert Syst. Appl.*, vol. 197, Jul. 2022, doi: <https://doi.org/10.1016/j.eswa.2022.116690>
- [8] M. E. Tavera, "Facultad de Derecho y Humanidades Escuela Profesional de Ciencias de la Comunicación," 2022.
- [9] J. Gu, M. Goetschalckx, and L. F. McGinnis, "Research on warehouse design and performance evaluation: A comprehensive review," *Eur. J. Oper. Res.*, vol. 203, no. 3, pp. 539–549, 2010, doi: <https://doi.org/10.1016/j.ejor.2009.07.031>
- [10] H. K. Smith, "Impact of robotic process automation (RPA) on e-supply chain coordination efficiency," Oct. 2024. [Online]. Available: <https://www.researchgate.net/publication/384808247>
- [11] S. Ramingwong, A. Sopadang, K. Y. Tippayawong, and J. Jintana, "Factory logistics improvement: A case study analysis of companies in northern Thailand, 2022–2024," *Logistics*, vol. 8, no. 3, p. 88, Sep. 2024, doi: <https://doi.org/10.3390/logistics8030088>
- [12] S. Aguirre and A. Rodriguez, "Automation of a business process using robotic process automation (RPA): A case study," in *Proc. Applied Computer Sciences in Engineering (WEA 2017), Communications in Computer and Information Science*, vol. 742, Springer, Aug. 2017, pp. 65–71, doi: https://doi.org/10.1007/978-3-319-66963-2_7
- [13] S. Pasupuleti, "Modeling and simulation in robotic process automation: Exploring potential for speed and efficiency in critical systems," *ESP Int. J. Advancements Sci. Technol.*, 2023, doi: <https://doi.org/10.56472/25839233/ijast-v1i2p108>
- [14] T. Kitsantas, P. Georgoulas, and E. Chytis, "Integrating robotic process automation with artificial intelligence for business process automation: Analysis, applications, and limitations," *J. Syst. Manag. Sci.*, vol. 14, no. 7, pp. 217–242, Jun. 2024, doi: <https://doi.org/10.33168/jsms.2024.0712>
- [15] X. Hu and Y. F. Chuang, "E-commerce warehouse layout optimization: Systematic layout planning using a genetic algorithm," *Electron. Commer. Res.*, vol. 23, no. 1, pp. 97–114, Jan. 2022, doi: <https://doi.org/10.1007/s10660-021-09521-9>
- [16] A. D. Valdivia Alfaro, G. S. Rentería Nuñez, and A. E. Flores Perez, "Implementation of 5S, SLP, standard work, ABC, and minimum and maximum system in a warehouse in metropolitan Lima: Improvement of OTIF orders," in *Proc. 2024 6th Int. Conf. Management Science and Industrial Engineering (MSIE '24), ACM Int. Conf. Proc. Ser., Assoc. Comput. Mach.*, Aug. 2024, pp. 351–358, doi: <https://doi.org/10.1145/3664968.3665016>
- [17] C. A. Ramirez-Cruz, L. Salirrosas-Espinoza, and J. C. Quiroz-Flores, "Implementing lean manufacturing and SLP tools to reduce order errors in a pharmaceutical warehouse in Peru," in *Proc. 2023 10th Int. Conf. Industrial*

Engineering and Applications (ICIEAEU '23), ACM Int. Conf. Proc. Ser., Assoc. Comput. Mach., Jun. 2023, pp. 192–198, doi: <https://doi.org/10.1145/3587889.3588199>

- [18] E. Badharinath, V. D. Reddy, P. S. Kumar, and A. K. Damodaram, “Optimization of manufacturing plant layout using systematic layout planning (SLP) method,” in *Proc. 2nd Int. Conf. Sustainable Technologies and Advances in Automation, Aerospace and Robotics (STAAAR 2023)*, MATEC Web Conf., vol. 393, p. 01005, Mar. 2024, doi: <https://doi.org/10.1051/mateconf/202439301005>
- [19] E. Marcelo-Alfaro, S. Rodríguez-Escobedo, R. Moore-Torres, and C. Torres, “Storage management model based on lean warehouse management and systematic layout planning,” in *Proc. 22nd LACCEI Int. Multi-Conf. Eng., Educ., Technol., Latin Amer. Caribbean Consortium Eng. Institutions*, 2024, doi: <https://doi.org/10.18687/LACCEI2024.1.1.1805>
- [20] A. Avdeikins and M. Savrasovs, “Making warehouse logistics smart by effective placement strategy based on genetic algorithms,” *Transp. Telecommun.*, vol. 20, no. 4, pp. 318–324, Dec. 2019, doi: <https://doi.org/10.2478/ttj-2019-0026>
- [21] R. Gonzales-Vasquez, C. A. Lobato-Tello, and A. Flores-Perez, “Application of ABC, slotting, and EOQ to increase productivity in a trading company: An empirical research in Peru,” in *Proc. 4th Asia Pacific Int. Conf. Industrial Engineering and Operations Management*, Sep. 2023, doi: <https://doi.org/10.46254/AP04.20230202>
- [22] X. P. Flores Gutiérrez, Y. B. Cota Pardini, and R. Loredó Medina, “Redistribución de inventario con base en clasificación ABC para mejorar el flujo de materiales en una empresa productora de alimentos en Sinaloa, México,” *Ing. Ind.*, no. 44, pp. 65–80, Jun. 2023, doi: <https://doi.org/10.26439/ing.ind2023.n44.6244>
- [23] S. Özhan Doğan, A. Karataş, and N. Bulduk, “System integration with slotting and ABC analysis,” *Int. J. Comput. Exp. Sci. Eng.*, vol. 10, no. 4, pp. 1765–1769, Dec. 2024, doi: <https://doi.org/10.22399/ijcesen.784>
- [24] A. Silva, K. J. Roodbergen, L. C. Coelho, and M. Darvish, “Estimating optimal ABC zone sizes in manual warehouses,” CIRRELT Working Paper, CIRRELT-2021-22, May 2021. [Online]. Available: <https://doi.org/10.13140/RG.2.2.15357.28645>

BIOGRAPHICAL NOTES

ELIZABETH SUMIE CASTILLO VERA

Elizabeth Sumie Castillo Vera holds a Bachelor's degree in Industrial Engineering from Universidad de Lima, Peru. She currently works as a Category Strategy & Innovation Analyst at Belcorp. Her research interests focus on business strategy and innovation, data analysis and quantitative models applied to decision-making, market research and consumer behavior, and process optimization and improvement.

GIAN PAUL FABIÁN ROBLES FLORES

Gian Paul Fabián Robles Flores holds a Bachelor's degree in Industrial Engineering from Universidad de Lima, Peru. He has corporate experience in the B2B commercial field at Alicorp and in commercial management for the Men's Retail division at Ripley. His research interests focus on the development and implementation of strategies, the analysis of factors and data for decision-making, and the optimization and improvement of internal processes aimed at generating value and benefits for consumers.

JOSÉ ANTONIO TAQUÍA GUTIÉRREZ

José Antonio Taquía Gutiérrez holds a PhD in Business Management from Universidad Nacional Mayor de San Marcos and a Master's degree in Industrial Engineering from Universidad de Lima. In the private sector, he has participated in several technology project implementations applied to operations in supply chain processes and decision-support systems for leading retail companies. He has also developed projects for the Instituto de Investigación Científica de Universidad de Lima. His main research interests are process improvement, predictive analytics, and Industry 4.0.

MARÍA TERESA NORIEGA ARANIBAR DE LAVALLE

María Teresa Noriega Aranibar de Lavalles holds a PhD in Accounting and Business Sciences from Universidad Nacional Mayor de San Marcos, a Master's degree in Forest Industries from Universidad Nacional Agraria La Molina, and a degree in Industrial Engineering from Universidad de Lima. She is Editor of the *Ingeniería Industrial* journal of Universidad de Lima, Full Professor in the Faculty of Engineering, and a researcher and thesis and research project advisor in the field of engineering. She has also served as an evaluator for the National Quality Award. She is co-author of the books *Project Portfolio*, *Techniques for Work Study*, *Continuous Improvement of Processes*, *Plant Layout*, and *Manual for the Design of Manufacturing and Service Facilities*, and author of several indexed articles.

Integrated Application of MRP, ABC, and SLP to Reduce Internal Supply Time for Pinch Valve Production in a Peruvian Metalworking Company

Jhoanna M. Alcantara Ramos¹ , Gianella Montenegro Espinoza² , Edilberto Avalos-Ortecho³ ,

Silvia P. Ponce Alvarez⁴ 

¹20202463@aloe.ulima.edu.pe, ²20193109@aloe.ulima.edu.pe, ³eavalos@ulima.edu.pe, ⁴sponce@ulima.edu.pe

¹²³⁴Carrera de Ingeniería Industrial, Universidad de Lima, Perú

Received: August 12, 2025 / Accepted: September 19, 2025 / Published: 5 June, 2026

doi: <https://doi.org/10.26439/ciii2025.8651>

ABSTRACT—This study improves the internal supply of critical materials for pinch valve production in a Peruvian metalworking firm by applying Material Requirements Planning (MRP), ABC classification, and Systematic Layout Planning (SLP) to reduce lead times and enhance inventory flow. A representative sample from key warehouses was analyzed. AS-IS and TO-BE scenarios were simulated in Arena (62 replications) evaluating picking time, logistics lead time, and fulfillment rate. Results show a 10% drop in picking time and a more than 23% rise in fulfillment, confirming the combined tools' effectiveness. The scalable methodology offers benefits for similar production lines.

Index Terms—ABC analysis, industrial engineering, internal supply, logistics, MRP, simulation, SLP.

I. INTRODUCTION

The Peruvian metalworking sector plays a key role in mining, construction, and energy, contributing 12.5% of manufacturing GDP (S/ 71,700 million in 2021). Within this sector, the fabricated metal products subsector accounted for 11.2% of gross industrial value added [1]. However, operational gaps persist as the Perfect Order Fulfillment rate stands at 76.21%, below the optimal 80–90%, indicating recurrent delays and inefficient internal material flow [2].

Material Requirements Planning (MRP) supports material demand planning in multi-component, make-to-order environments. A 2022 study incorporating a stochastic MRP cut backorders by over 50%, reduced total cost by

23%, and improved service levels by 18%, enhancing planning stability under demand variability [3]. In 2023, MRP outperformed Reorder Point System (RPS) and Constant Work In Process (CONWIP) in cycle times and logistics cost reduction, improving warehouse–production coordination and preventing stockouts and delays [4].

ABC classification prioritizes materials based on value or turnover. In a 2023 metalworking case, the integration of ABC with the 5S methodology and Systematic Layout Planning (SLP) reduced defects by 12% and increased productivity by 15% [5]. Similarly, a 2021 application in a Chinese supermarket distribution center improved storage efficiency from 87.7% to 96.5% and order accuracy from 97.3% to 100% by reorganizing the layout according to item criticality [6]. SLP optimizes internal layouts to improve flow; a 2022 automotive case, productivity was increased and labor costs were reduced by 40% [7]. In Peru, the application of SLP combined with process standardization increased the On-Time In-Full (OTIF) rate from 53.6% to 92.9% [8].

In the Peruvian metalworking sector, internal supply delays of 5–7 days and 38% of urgent internal orders—well above the <10% threshold—have been reported [8]. This study applies MRP, ABC, First-In, First-Out (FIFO), and SLP to cut supply times to ≤3 days by improving planning, inventory management, and layout design. The hypothesis is that integrating these tools will reduce supply times and urgent orders, improving OTIF (approximately 76% vs. 90% target) [9], Table I while boosting productivity and controlling costs. Validation involved a 9-month pilot, simulation modeling, and economic, social, and environmental analyses.

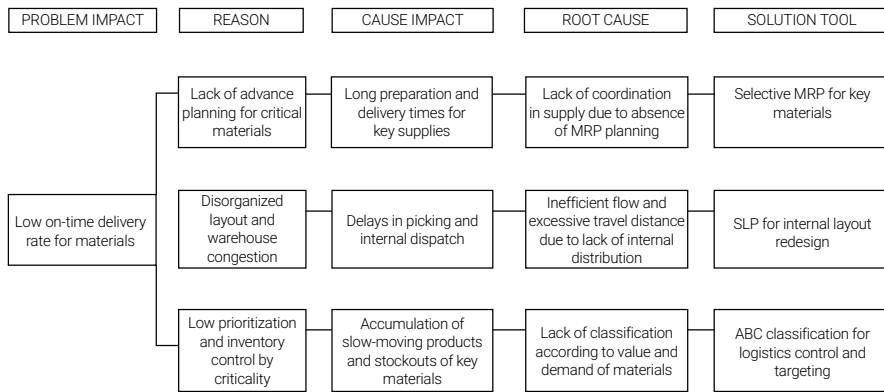

Fig. 1. Problem tree.

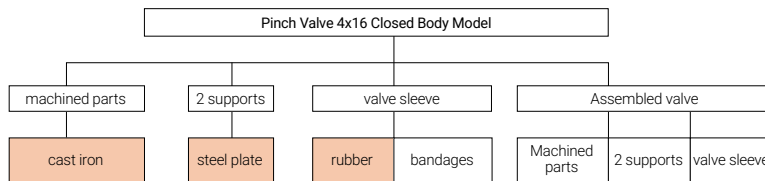

Fig. 2. Gozinto diagram.

II. METHODS

This study employs a quantitative methodology based on the collection, analysis, and comparison of measurable data, following a quasi-experimental design with a planned intervention. It focuses on the internal material supply flow—from valve pinch request to receipt in production—as outlined in the problem tree (Fig. 1).

A Lean Warehousing approach was applied following the diagnostic phase, which included plant observations, staff interviews, and Enterprise Resource Planning (ERP) snapshots [10]. The unit of analysis was internal supply time for pinch valve orders [11]. Using non-probabilistic convenience sampling (January 2023–June 2025), the model was validated in a nine-month pilot test (October 2024–June 2025) with 540 orders, Arena simulations (AS-IS vs. TO-BE), and economic, social, and environmental assessments.

Data were collected using tailored forms, calculation sheets, and direct observation, capturing supply times, layout distances, inventory levels, and order frequency—thus supporting bottleneck identification and layout mapping.

The Gozinto diagram in Fig. 2 displays the hierarchical structure of inputs for producing the 4x16” pinch valve model, while the MRP plan for RSS1 rubber is detailed in Table II.

- Type: First-phase MRP (no finite capacity).
- 1 valve = 5 cast parts + 1 steel plate + 0.2 kg RSS1 rubber.

TABLE I

MAIN TECHNICAL GAP INDICATORS

Indicators	Current value	Proposed target	Technical gap
Total delivery time	6 days	≤3 days	3 days
Picking travel time	1.41 h	<1.20 h	0.21 h
OTIF compliance %	76%	≥90%	14%

- Horizon: Oct 2024–Jun 2025 (10 valves/month).
- Demand: 30–40 monthly valve orders.
- Key parameters: fixed lot sizes, per-input lead times, initial inventory, safety stock.

The MRP formulas used include the available inventory calculation and the order release condition, as shown in (1) and (2).

$$\text{Available inventory} = \text{Beginning inventory} + \text{Scheduled reception} - \text{Period demand} \quad (1)$$

$$\text{Available inventory} < \text{Safety stock} \quad (2)$$

If an order is released in week n , the receipt occurs as defined in (3).

$$\text{Receipt week} = n + \text{lead time} \quad (3)$$

TABLE II
MRP DIAGRAM

Initial Inv	40	lead time	2	safety stock	20	batch	120	kg				
RSS1 Rubber	oct-24				nov-24				dic-24			
	1	2	3	4	5	6	7	8	9	10	11	12
Demand	14	14	14	14	14	14	14	14	18	18	18	18
Gross Req	56	56	56	56	56	56	56	56	72	72	72	72
Scheduled Receipts			120	120	120				120		120	120
On-hand Inventory	-16	-72	-8	56	120	64	8	-48	0	-72	-24	24
Net Req	120	120	120					120		120	120	120
Order Receipts	120	120	120					120		120	120	120

RSS1 Rubber	ene-25				feb-25				mar-25			
	1	2	3	4	5	6	7	8	9	10	11	12
Demand	16	16	16	16	18	18	18	18	14	14	14	14
Gross Req	64	64	64	64	72	72	72	72	56	56	56	56
Scheduled Receipts			120	120	120	120	120	120			120	120
On-hand Inventory	-40	-104	-48	-112	-64	-16	32	80	24	-32	-88	-24
Net Req	120		120	120	120	120				120	120	120
Order Receipts	120		120	120	120	120				120	120	120

RSS1 Rubber	abr-25				may-25				jun-25			
	1	2	3	4	5	6	7	8	9	10	11	12
Demand	14	14	14	14	15	15	15	15	18	18	18	18
Gross Req	56	56	56	56	60	60	60	60	72	72	72	72
Scheduled Receipts			120	120	120	120				120	120	120
On-hand Inventory	-80	-136	-72	-8	52	112	52	-8	-80	-32	16	64
Net Req	120	120	120	120				120	120	120		
Order Receipts	120	120	120	120				120	120	120		

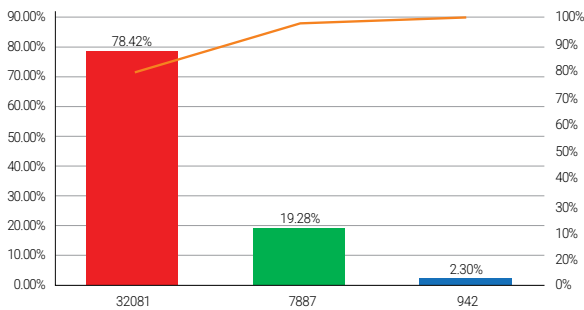

Fig. 3. Pareto classification diagram.

TABLE III
ABC CLASSIFICATION IN FAMILIES

Product	Inventory proportion	Cumulative inventory share	ABC	Cumulative product share
Prepolymer	24%	24%	A	
Red pigment	21%	45%	A	
Release agent PU515	15.4%	60.4%	A	20%
Silicone emulsion EM's	14.7%	75.1%	A	
DPG "N"	7.9%	83%	A	
Ultralube	5.8%	88.8%	B	40%
Struktol ZB	3.8%	92.6%	B	
Kaolin	2.7%	95.3%	C	60%
Granulated TMTD "N"	2.6%	97.9%	C	
Scarlet red dye	2.1%	100%	C	100%

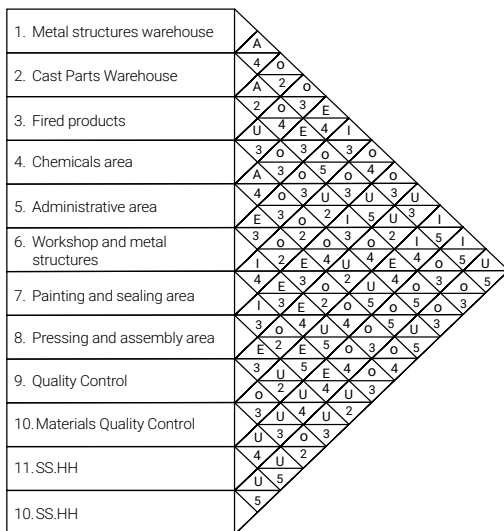

Fig. 4. Activity relationship diagram.

TABLE IV
TIME AND DISTANCE MEASUREMENTS

Process	Current time/Distance	
	Time	Distance
Material Arrival Quality – Warehouse	15 min	8 m
Warehouse – Administrative Area	10 min	26 m
Administrative Area – Warehouse	10 min	26 m
Warehouse – Specific Area	24 min	14 m
Specific Area – Quality Control	8 min	28 m
Quality Control – Finished Goods Warehouse	10 min	6 m

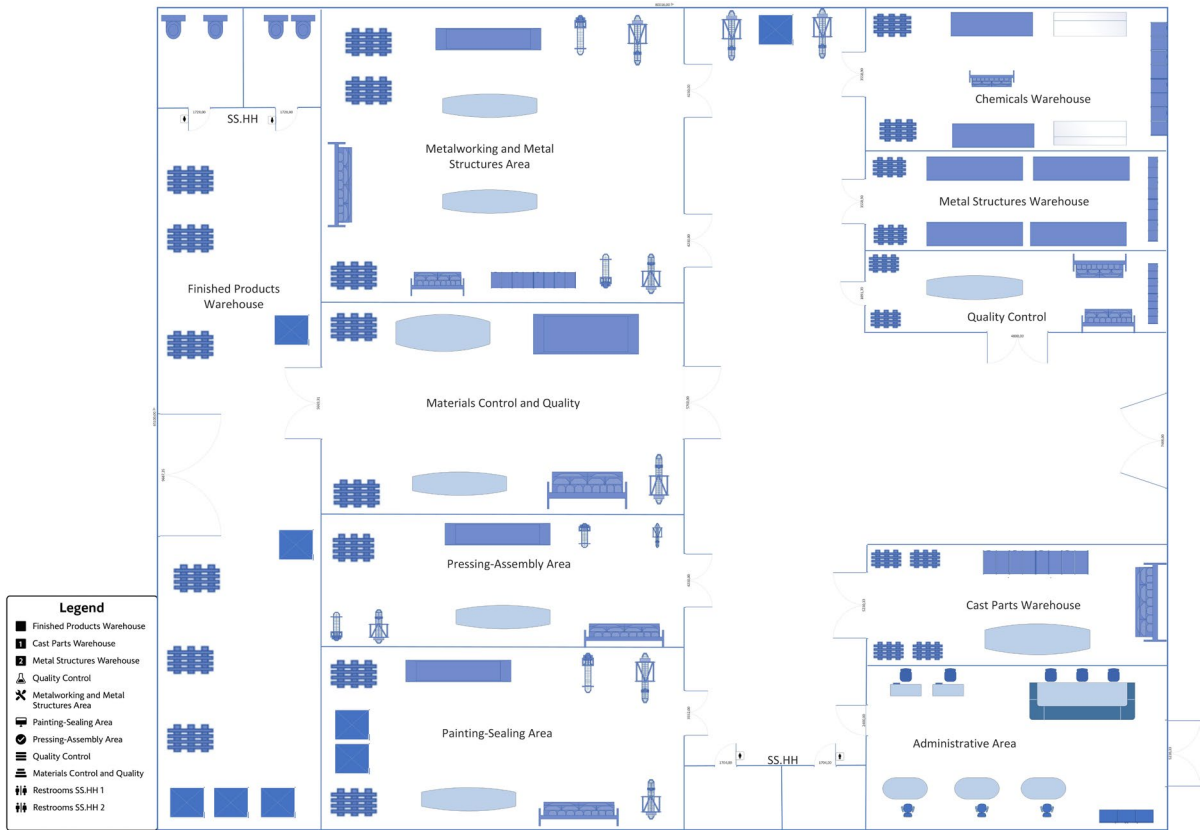

Fig. 5. Current layout plan.

The ABC classification applied in the chemical warehouse began with collecting inventory data, organizing materials within the software, and classifying them based on their contribution to total inventory cost. Among 28 chemical inputs, items were grouped into 10 material-type families in Table III. Weekly data collection enabled the construction of a Pareto diagram in Fig. 3 showing Type A (highest cost), Type B (next 20%), and Type C (remaining items).

After organizing the materials warehouse, shelves were labeled according to material type and chemical product expiration dates. The SLP tool was then applied using proximity analysis and an activity relationship diagram (Fig. 4) to reorganize material transfer areas toward production, as shown in the layout presented in Fig. 5. Table IV lists time and distance data from sequential area movements, starting from production requests. Route crossings were identified among the chemical warehouse, the cast parts warehouse, and the material quality control area.

The model was validated by comparing the simulated processing time with the actual historical time of 48 h. In addition, the Arena Input Analyzer module, summarized in Table V, was used to determine the input probability distributions for each process shown in Fig. 6.

TABLE VI
UNIT INDICATORS

No.	Indicators	
	Indicators	Unity
1	Average internal supply time	Hours
2	Average travel distance	Meters
3	Requisition compliance rate RQ	%
4	Product quality rate	%

The procedure, supported by prior diagnosis and data collection, included training activities, tool monitoring, and periodic reviews. The model was validated through Arena simulations of the AS-IS scenario, shown in Figs. 7 and 8, which represent the supply flow from request generation to production [12]. This approach enables scenario modeling, integrates real-time data, and accounts for process constraints. The key performance indicator (KPI) analysis presented in Table VI demonstrates significant improvements in material flow without requiring high capital investment.

TABLE V
INPUT ANALYZER

Variable	Distributions
Create module distribution time	$0.999 + 0.641 \times \text{BETA}(1.09, 1.29)$ days
Order registration	UNIF(15, 19.8) min
Material validation	UNIF(1, 1.61) h
Generate purchase requisition (RQ)	$25 + 10 \times \text{BETA}(1.09, 0.969)$ min
Request quotation	UNIF(80, 100) min
Issue purchase order	$0 + 10 \times \text{BETA}(1.08, 1.05)$ min
Supplier lead time	$4 + 0.54 \times \text{BETA}(0.908, 1.08)$ days
Order reception	UNIF(15, 20) min
Re-sent order reception	$2 + 0.651 \times \text{BETA}(0.936, 1.35)$ min
Technical control	$28 + 6 \times \text{BETA}(1.43, 1.29)$ min
Issue control delivery note	$19 + 2.79 \times \text{BETA}(0.728, 0.789)$ min
Return material control from supplier	UNIF(20, 28) min
Quality control	CONT (0.000, 3.000, 0.382, 3.249, 0.509, 3.497, 0.564, 3.746, 0.564, 3.994, 0.782, 4.243, 0.945, 4.491, 1, 4.740)
Issue quality delivery note	CONT (0.000, 3.000, 0.229, 3.285, 0.521, 3.570, 0.521, 3.855, 0.625, 4.140, 0.833, 4.425, 1, 4.710)
Return material to quality from supplier	$20 + 10 \times \text{BETA}(0.973, 1.23)$ min
Locate and label	$5 + 5 \times \text{BETA}(1.42, 1.24)$ min
Approve warehouse RQ	UNIF(22, 30) min
Verify material location	UNIF(22, 28) min
Internal warehouse travel	$(16 + 3.89 \times \text{BETA}(0.648, 0.869))$ min
Forklift loading	$(15 + 2.77 \times \text{BETA}(0.868, 0.747))$ min
Transfer to production	UNIF(15, 19.9) min

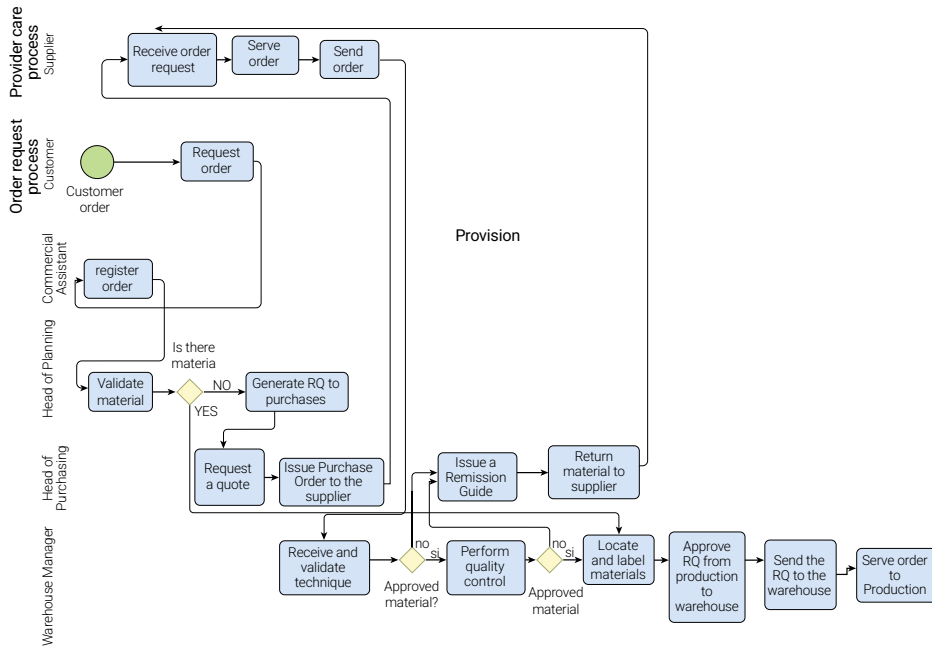

Fig. 6. Bizagi modeler.

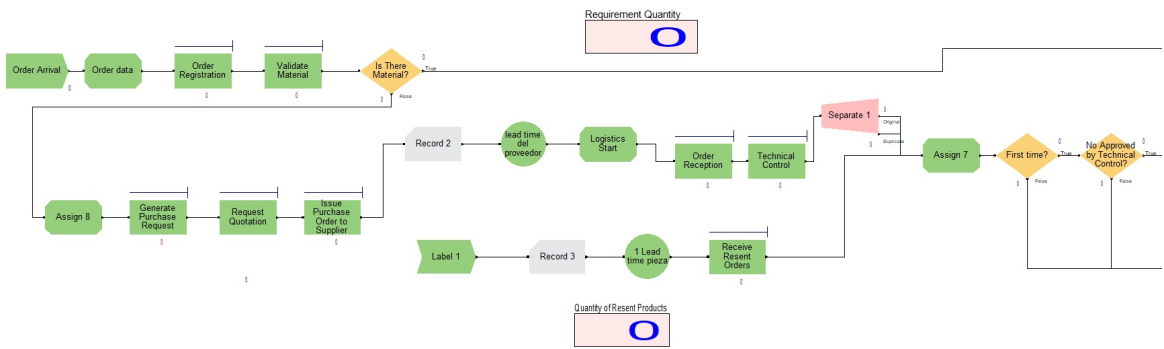

Fig. 7. AS-IS scenario—Part 1.

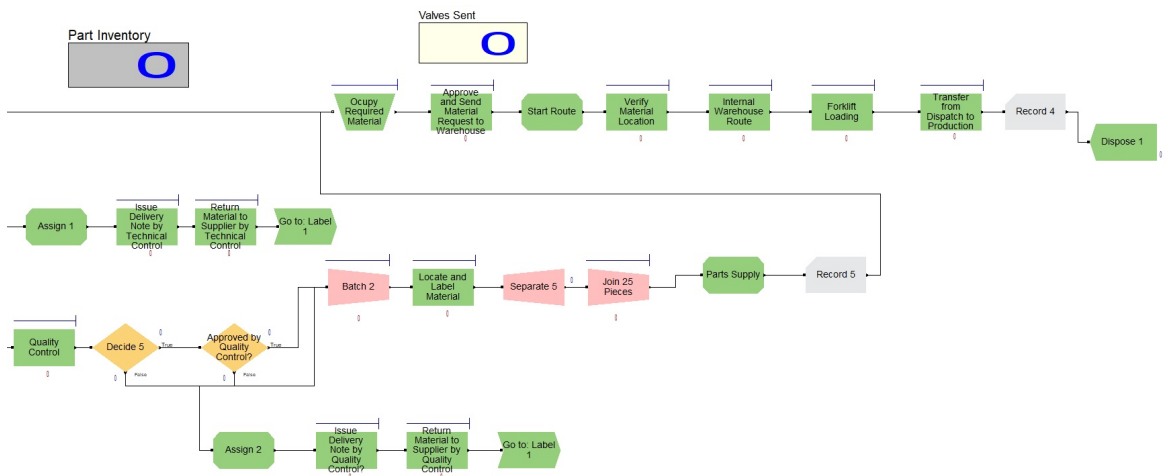

Fig. 8. AS-IS scenario—Part 2.

The simulation was executed with 62 replications, in accordance with standard sample size determination formulas commonly used in inventory simulation studies [13].

$$R = \left(\frac{Z \cdot S}{e \cdot \bar{X}} \right)^2 \quad (4)$$

The performance indicators obtained from the simulation are presented in Fig. 9, which represents the company's current operational state.

III. RESULTS

Data on processing and waiting times, logistics routes, inventory turnover, RQ fulfillment, and layouts were collected. ERP screenshots and evidence of MRP and layout changes supported the TO-BE simulation.

Quantitative analysis used averages, percentages, and fulfillment rates. Arena simulations ran 62 replications per scenario (AS-IS, First, Second) at 95% level confidence.

In Scenario 1, MRP and ABC classification were implemented, with Technical Control approval set at 90% and Quality Control approval at 95%. Component supply was modeled using an Assign module, as defined in (5).

$$MR(\text{cast_iron_part}) + 100 \quad (5)$$

Fig. 10 shows improved indicators over the current model in Fig. 7 and Fig. 8.

The improvement was achieved through the implementation of the SLP tool and the corresponding layout modification in the study area. Fig. 13 illustrates the improvement in performance indicators compared with the initial AS-IS simulation. In addition, Fig. 11 and Fig. 12 display the Arena model, highlighting the improvements resulting from the integrated implementation of all proposed tools.

In the second scenario, the total delivery time, shown in Fig. 14, decreased from 46.39 to 18.76 h (–59.6%) as a result of improved planning through MRP and the elimination of

ARENA Simulation Results
JHOANNA - License: STUDENT

Output Summary for 62 Replications

Project: Unnamed Project
Analyst: NB-Gianella Montenegro

Run execution date : 6/ 21/2025
Model revision date: 6/ 21/2025

Identifier	Average	Half-width	Minimum	Maximum	# Replications
Quality	77.486	.52869	71.686	81.311	62
Routing Lead time	1.4642	.04737	1.2454	1.9988	62
Requirement 1 Lead Time	53.061	.42311	49.675	57.019	62
Production Requirement Fulfillment Rate	76.003	.81374	69.230	84.615	62
Total parts requirement	15.451	.12887	15.000	14.000	62
Overall Lead Time 1	46.391	.42550	42.961	50.060	62
Valve Lot Ready	52.258	.82288	45.000	55.000	62
Internal Logistics Lead Time	16.674	.38880	13.128	20.508	62

Fig. 9. AS-IS results.

ARENA Simulation Results
JHOANNA - License: STUDENT

Output Summary for 62 Replications

Project: Unnamed Project
Analyst: NB-Gianella Montenegro

Run execution date : 6/21/2025
Model revision date: 6/21/2025

Identifier	Average	Half width	Minimum	Maximum	# Replications
Quality	87.099	.73247	80.645	93.283	62
Routing Lead time	1.4554	.04232	1.2533	1.9459	62
Requirement 1 Lead Time	49.056	.48265	44.602	54.717	62
Production Requirement Fulfillment Rate	100.00	.00000	100.00	100.00	62
Total Parts Requirement	5.2096	.13972	4.0000	7.0000	62
Overall Lead Time 1	19.139	.53342	13.933	24.633	62
Valve Lot Ready	70.629	.83869	75.000	85.000	62
Internal Logistics Lead Time	12.725	.45282	9.3525	17.718	62

Fig. 10. First-scenario results.

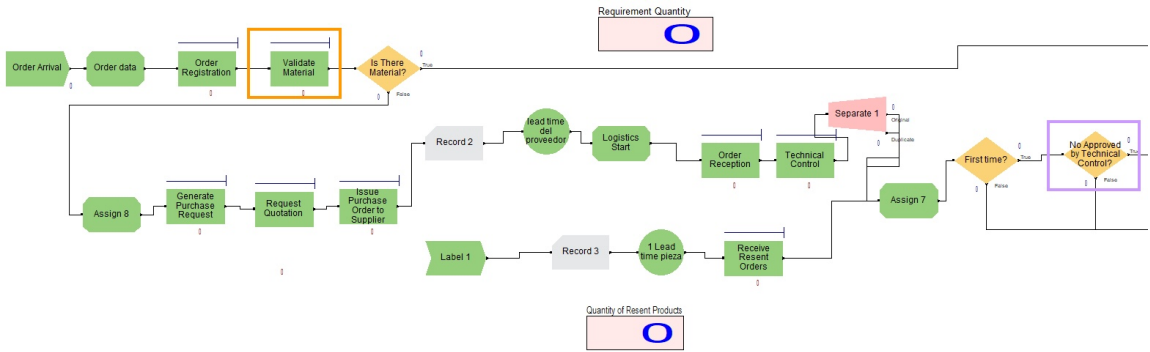

Fig. 11. Best scenario 1.

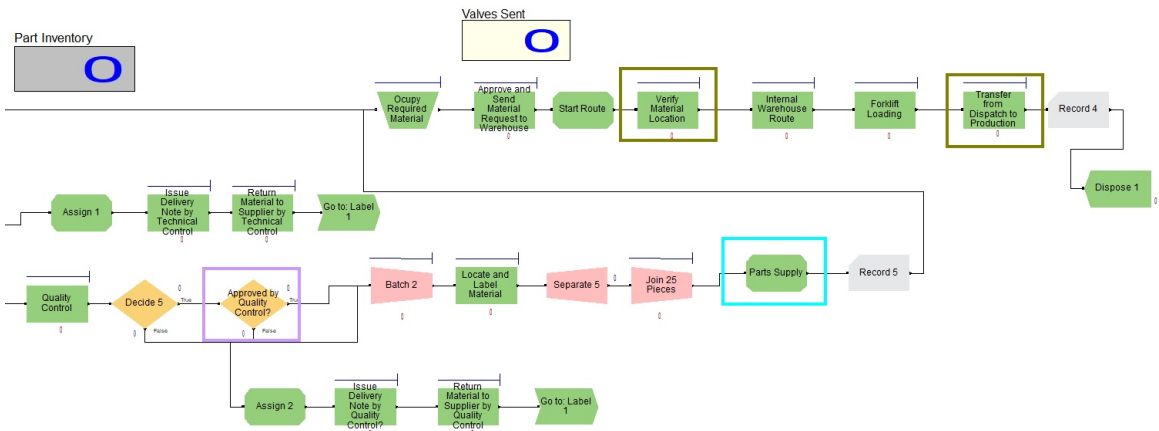

Fig. 12. Best scenario 2.

ARENA Simulation Results
JHOANNA - License: STUDENT

Output Summary for 62 Replications

Project: Unnamed Project
Analyst: NB-Gianella Montenegro

Run execution date : 6/21/2025
Model revision date: 6/21/2025

Identifier	Average	Half-width	Minimum	Maximum	# Replications
Quality	87.031	.78428	81.521	93.283	62
Routing Lead time	1.1128	.03090	.97197	1.4981	62
Requirement 1 Lead Time	48.964	.45282	44.602	53.108	62
Production Requirement Fulfillment Rate	100.00	.00000	100.00	100.00	62
Total Parts Requirement	5.2096	.13972	4.0000	7.0000	62
Overall lead Time 1	18.768	.48306	13.951	23.511	62
Valve Lot Ready	78.548	.84560	75.000	85.000	62
Internal Logistics Lead Time	12.638	.42353	8.6451	16.537	62

Fig. 13. Second-scenario results.

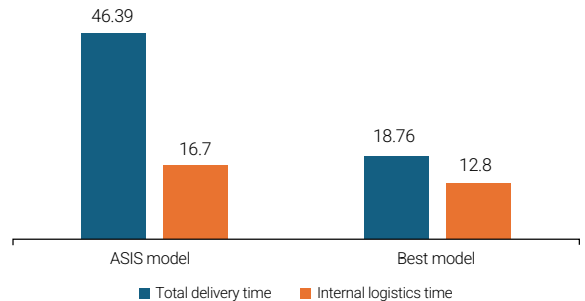

Fig. 14. Time indicators.

delays. Internal logistics time also decreased, from 18.76 to 12.8 h (-31.8%), driven by the implementation of SLP and the ABC-based prioritization of Type A materials near the dispatch area.

These results indicate a clear optimization of internal logistics, with a positive impact on operational efficiency.

Fig. 15 displays the variation in average picking travel time before and after the implemented improvements.

- In the AS-IS model, the average was 1.32 h, reflecting a dispersed and inefficient layout.
- With the application of SLP and ABC prioritization in the second scenario, this value was reduced to 1.11 h (-15.9%).

This result is consistent with the findings reported in [14], which indicate that SLP improves access to critical materials and reduces unnecessary movements in logistics warehouses.

Fig. 16 displays the key efficiency indicators: production RQ fulfillment increased from 76% to 100% through the implementation of MRP, enabling demand-based planning; moreover, the product quality rate rose from 77.33% to 87% as a result of reduced urgent deliveries and improved storage conditions that prevent material deterioration. These outcomes corroborate the findings reported in [15], indicating that the integration of MRP with functional layout design enhances OTIF performance and final product quality.

A comparative analysis was conducted between the AS-IS and the best scenarios to evaluate the impact of the tools applied (MRP, ABC, SLP). Table VII summarizes the KPIs obtained from the Arena simulation.

Prior to implementing the MRP system, material planning in the valve pinch line was reactive and decentralized. Requests for critical materials—such as RSS1 rubber, cast parts, and steel plates—were generated manually after receiving production orders, with no planning horizon, safety stock levels, or supplier lead times considered in Fig. 17.

This resulted in frequent urgent orders, production rescheduling, and inefficient use of logistics resources.

With the application of first-phase MRP, in Fig. 18 forward planning was established based on average monthly consumption, lead times, fixed order sizes, initial inventory, and safety stock. This enabled earlier ordering, improved inventory coverage, and ensured timely availability of materials, reducing stockouts and delays.

The warehouse diagnosis revealed a disorganized layout lacking prioritization by material criticality or consumption value, which resulted in excessive travel distances, picking errors, and long search times. The application of ABC classification enabled a reorganization of the layout, positioning Type A inputs near the dispatch area and assigning Types B and C to secondary storage zones. Fig. 19 shows the improved layout prototype. This redesign reduced search time by 20% and improved control of key items, consistent with previous findings [16].

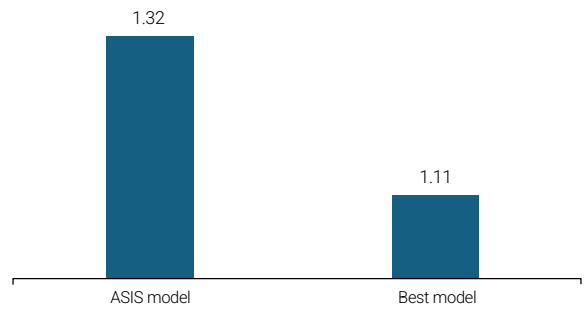

Fig. 15. Picking indicators.

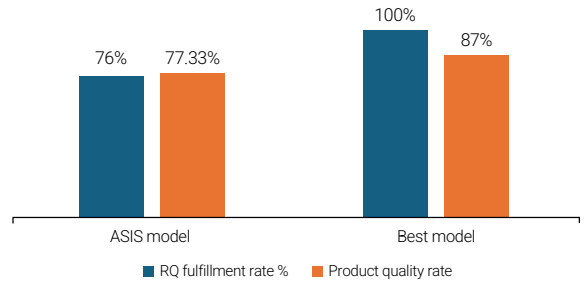

Fig. 16. Percentage indicators.



Fig. 17. Initial state of RSS1.

TABLE VII
INDICATORS

Indicator	AS-IS model	First scenario	Best model	Improv.	Unity
Total delivery time	46.39	19.14	18.76	-27.63	h
Internal logistics time	16.7	12.7	12.8	-4	h
Average picking distance	1.32	1.46	1.11	0.21	h
RQ fulfillment rate %	76	100	100	+23	%
Product quality rate	77.33	87	87	+11	%

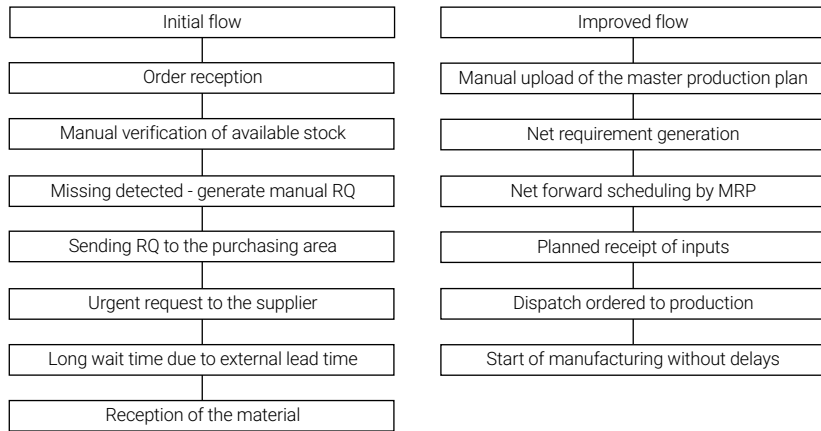

Fig. 18. Initial and optimized MRP flow for the critical Cucho RSS1 material.

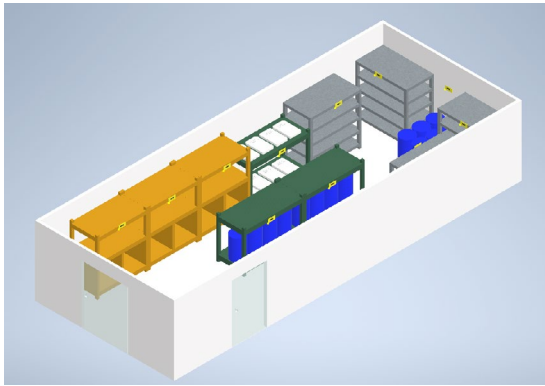

Fig. 19. Improved warehouse.

Prior to the improvement, the warehouse layout was inefficient, with critical materials dispersed throughout the facility, resulting in excessive travel distances, route overlaps, and operational delays. Fig. 19 displays low-turnover items placed closer to dispatch than high-priority ones. In the second and best scenario, the SLP methodology redesigned the internal flow, emphasizing proximity, frequency, and activity compatibility as shown in Fig. 20. This reduced operator travel time and improved access to key materials, as also demonstrated in [14], where SLP increased productivity by up to 30% by minimizing idle time and movement.

Overall, the results show notable improvements in internal supply to production through the combined application of MRP, ABC classification, and SLP. The reduced logistics times (Table VIII), higher fulfillment rates, and better access to critical materials confirm the effectiveness of the proposed redesign. These outcomes result from the integration of planning, inventory segmentation, and layout reorganization, aligned with the study’s objectives.

TABLE VIII
INDICATORS

Process	Current time/Distance	
	New time	New distance
Material Arrival Quality – Warehouse	12 min	6 m
Warehouse – Administrative Area	6 min	22 m
Administrative Area – Warehouse	8 min	24 m
Warehouse – Specific Area	16 min	10 m
Specific Area – Quality Control	6 min	26 m
Quality Control – Finished Goods Warehouse	7 min	4 m

IV. DISCUSSION

The findings indicate a 59.6% reduction in total delivery time and a 24% increase in the fulfillment rate of material requests (RQ), thereby validating the initial hypothesis. The implementation of MRP enabled the anticipation of actual production demand, reducing urgent orders and stockouts. These results are consistent with those reported in [17], which show that MRP can reduce supply failures by more than 20% in customized manufacturing environments.

ABC classification facilitated the prioritization of critical materials, thereby improving inventory turnover. This result is consistent with the findings reported in [18], where the application of this technique enabled a reduction in obsolete stock in industrial logistics warehouses. Finally, the implementation of SLP enabled shorter and more organized material handling routes. This result is consistent with the findings reported in [14], which document efficiency improvements of up to 30% through well-planned physical layout redesigns.

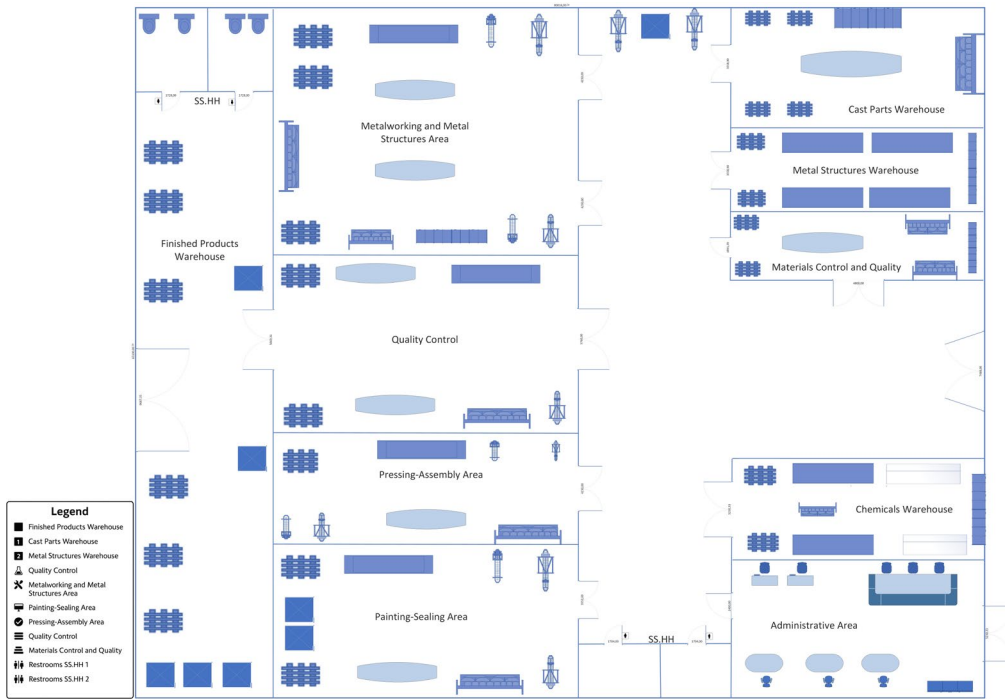

Fig. 20. Proposed layout plan.

A key strength of this research lies in its practical approach, combining real-world field implementation with simulation-based validation to enable a comparative analysis of system performance before and after each tool's application. Despite the positive results obtained, it should be noted that the implemented MRP model followed a first-phase approach, without incorporating finite capacity constraints or advanced demand forecasting. This is because the company operates under a make-to-order production system, where demand is defined by specific orders. Furthermore, although this study focused on a critical production line (pinch valves), the applied methodology can be replicated across other production lines or warehouses within the company. These considerations do not diminish the value of the work; instead, they open opportunities for future research to extend opportunities for future research to deepen the analysis with complementary tools and broader organizational coverage.

V. CONCLUSION

The results of the study confirm the proposed hypothesis: the combined application of MRP, ABC classification, and SLP significantly reduces internal supply times in a make-to-order metal-mechanical company. Specifically, total delivery time decreased by 59.6% (from 46.39 to 18.76 h), internal logistics time was reduced by 31.8% (from 16.7 to 12.8 h), and average picking time declined by 15.9% (from

1.32 to 1.11 h). In addition, the production requirement (RQ) fulfillment rate increased by 23 percentage points (from 76% to 100%), and the product quality rate improved by nearly 10 percentage points (from 77.33% to 87%). These improvements were validated through Arena simulation (62 replications at a 95% confidence level) and a nine-month pilot implementation involving 540 valve orders, demonstrating that the integration of these logistics tools effectively optimizes critical material flows, reduces urgent orders, and enhances operational reliability in Peruvian industrial environments.

REFERENCES

- [1] Ministerio de Producción del Perú, "Reporte de Producción Manufacturera [Manufacturing Production Report]," Ministerio de Producción del Perú, Lima, Perú, Apr. 2022. [Online]. Available: <https://ogeiee.produce.gob.pe/index.php/en/shortcode/oee-documentos-publicaciones/boletines-industria-manufacturera/item/1047-2022-abril-report-de-produccion-manufacturera>
- [2] A. Anton, M. Roque, and E. Ramos, "Lean warehousing model to improve the order fulfillment in a metalworking company," in *8th Int. Conf. Ind. & Bus. Eng. (ICIBE 2022)*, Jan. 2023, pp. 90-95, doi: <https://doi.org/10.1145/3568834.3568881>

- [3] S. Thevenin, Y. Adulyasak, and J. Cordeau, "Material requirements planning under demand uncertainty using stochastic optimization," *Prod. Oper. Manag.*, vol. 30, no. 2, pp. 475-493, Feb. 2021, doi: <https://doi.org/10.1111/poms.13277>
- [4] M. He, Z. Guan, C. Wang, and G. Hou, "A shipborne dense storage warehouse system based on two-way transportation line strategy," in *5th Int. Conf. Ind. Eng. Ind. Manag. (IEIM 2024)*, Nice, France, Mar. 2024, pp. 215-223, doi: https://doi.org/10.1007/978-3-031-56373-7_17
- [5] A. D. Valdivia Alfaro, G. S. Renteria Nuñez, and A. E. Flores Perez, "Implementation of 5S, SLP, standard work, ABC and minimum and maximum system in a warehouse in Metropolitan Lima," in *6th Int. Conf. Manag. Sci. Ind. Eng. (MSIE 2024)*, Bangkok, Thailand, Aug. 2024, pp. 351-358, doi: <https://doi.org/10.1145/3664968.3665016>
- [6] H.-L. Lin and Y.-Y. Ma, "A new method of storage management based on ABC classification: A case study in Chinese supermarkets' distribution center," *Sage Open*, vol. 11, no. 2, Jun. 2021, doi: <https://doi.org/10.1177/21582440211023193>
- [7] E. Leon-Enrique, V. Torres-Calvo, M. Collao-Diaz, and A. Flores-Perez, "Improvement model applying SLP and 5S to increase productivity of storaging process in a SME automotive sector in Peru," in *3rd Int. Conf. Ind. Eng. Ind. Manag. (IEIM 2022)*, Barcelona, Spain, May 2022, pp. 219-225, doi: <https://doi.org/10.1145/3524338.3524372>
- [8] R. F. P. Llanos Reyes, K. F. Flores Zorrilla, and M. F. Collao Diaz, "Service model based on lean manufacturing, SLP and process standardization to increase the service level of an SME in the metal-mechanic sector," in *6th Int. Conf. Inf. Manag. Manag. Sci. (IMMS 2023)*, Chengdu, China, Nov. 2023, pp. 207-213, doi: <https://doi.org/10.1145/3625469.3625513>
- [9] A. Briones-Chávez, N. Sandoval-Soldevilla, and J. C. Quiroz-Flores, "Applying lean warehousing tools to improve OTIF: A case study in a logistics SME in the freight transportation sector in Peru," *Int. J. Mech. Eng.*, vol. 12, no. 1, pp. 113-126, Jan. 2025, doi: <https://doi.org/10.14445/23488360/IJME-V12I1P113>
- [10] Y. A. Añazco-Alavedra and J. C. Quiroz-Flores, "Lean warehousing, 7S and SLP tools to improve productivity in the inspection and storage process in a spare parts warehouse of an automotive retail company," in *5th African Int. Conf. Ind. Eng. Oper. Manag. (AIEOM 2024)*, Pretoria, South Africa, Apr. 2024, doi: <https://doi.org/10.46254/af05.20240203>
- [11] Z. J. Ye et al., "Resilience patterns and transitions in the Be Resilient to Breast Cancer trial: An exploratory latent profile transition analysis," *Psycho-Oncology*, vol. 30, no. 6, pp. 901-909, Jun. 2021, doi: <https://doi.org/10.1002/pon.5668>
- [12] M. A. A. Abd Ghafar and F. Mohamad, "Warehouse performance improvement during big event using discrete event simulation approach: A case study of food and beverages company in Shah Alam," *J. Gov. Integr.*, vol. 6, no. 1, pp. 415-425, May 2023, doi: <https://doi.org/10.15282/jgi.6.1.2023.7544>
- [13] S. Ahmed Khan, F. Dweiri, and A. Chaabane, "Managing warehouse inventory: A simulation-based case study," presented at *11th Int. Conf. Model. Optim. Simul. (MOSIM 2016)*, Montréal, QC, Canada, Aug. 2016. [Online]. Available: <https://www.researchgate.net/publication/307173457>
- [14] J. Lee and C. Yang, "Deep neural network and meta-learning-based reactive sputtering with small data sample counts," *J. Manuf. Syst.*, vol. 62, pp. 703-717, Jan. 2022, doi: <https://doi.org/10.1016/j.jmsy.2022.02.004>
- [15] J. L. Adrianzén-Nuñez, G. Berrospi-Gálvez, M. F. Collao-Díaz, and J. C. Quiroz-Flores, "Optimizing logistics and inventory management in SMEs: Integrating economic order quantity and systematic layout planning in a Peruvian distribution company," in *9th North American Conf. Ind. Eng. Oper. Manag. (NAIEOM 2024)*, Washington, DC, USA, Jun. 2024, doi: <https://doi.org/10.46254/NA09.20240278>
- [16] X. Shen and B. Lin, "Does industrial structure distortion impact the energy intensity in China?," *Sustain. Prod. Consum.*, vol. 25, pp. 551-562, Jan. 2021, doi: <https://doi.org/10.1016/j.spc.2020.12.012>
- [17] G. Wang, W. Peng, and L. Zhang, "Estimate of population density and diagnosis of main factors of spatial heterogeneity in the metropolitan scale, western China," *Heliyon*, vol. 9, no. 6, e16285, Jun. 2023, doi: <https://doi.org/10.1016/j.heliyon.2023.e16285>
- [18] R. Seiger, L. Malburg, B. Weber, and R. Bergmann, "Integrating process management and event processing in smart factories: a systems architecture and use cases," *J. Manuf. Syst.*, vol. 63, pp. 575-592, Apr. 2022, doi: <https://doi.org/10.1016/j.jmsy.2022.05.012>

BIOGRAPHICAL NOTES

JHOANNA MILAGROS ALCANTARA RAMOS

Jhoanna Milagros Alcantara Ramos holds a Bachelor's degree in Industrial Engineering from Universidad de Lima, Peru. She currently works as a professional intern in the Safety and Environment area at Repsol, within the Exploration and Production Business Unit. She is co-author of the article "Integrated Application of MRP, ABC and SLP to Reduce Internal Supply Time for Pinch Valve Production in a Peruvian Metalworking Company," presented at the IV International Congress of Industrial Engineering. Her areas of interest include engineering projects, risk assessment, safety and environmental management (SMA), operational control, and machine learning.

GIANELLA YANATTE MICHELY MONTENEGRO ESPINOZA

Gianella Yanatte Michely Montenegro Espinoza holds a Bachelor's degree in Industrial Engineering from Universidad de Lima, Peru. Her academic background focuses on operations management, logistics, finance, and process improvement. She is currently a professional intern in the Network & Assets area at Corporación Primax, where she participates in activities related to asset management, data analysis, and decision-making support. She has also participated in university study groups as a member of the Virtual Design and Construction (VDC) Study Circle of the Civil Engineering Program, where she developed skills in project management and collaborative work. She is co-author of the article "Integrated Application of MRP, ABC and SLP to Reduce Internal Supply Time for Pinch Valve Production in a Peruvian Metalworking Company," presented at the IV International Congress of Industrial Engineering. Her research interests include project management, logistics, finance, process management, and supply chain management.

EDILBERTO MIGUEL AVALOS ORTECHO

Edilberto Miguel Avalos Ortecho holds a PhD in Business Management from Universidad Nacional Mayor de San Marcos, an MBA in Strategic Business Management from Centrum Católica, and a Master's degree in Environmental Management and Administration from EOI Escuela de Organización Industrial, Spain. He is Coordinator of Research and Publications, Researcher, and Lecturer in

the Industrial Engineering Program at Universidad de Lima. He is registered in Renacyt at Level VI under code P0041763 and represents Peru on the ISO/TC 279 Technical Committee on Innovation Management. He has co-authored the publications "Implementation of Lean Manufacturing to Increase Aircraft Availability" (Journal of Fluid Flow, Heat and Mass Transfer); "Crude Oil Production and Simulation from Catalytic Fast Pyrolysis of Waste Polyethylene Terephthalate (PET)" (Cleaner Engineering and Technology, 2025); "Implementation of Machine Learning and BPM to Increase Profitability in a Travel Agency" (World Congress on Mechanical, Chemical, and Material Engineering, 2025); "Application of Lean Manufacturing to Increase Productivity in the Food Sector" (LACCEI 2025); and "Application of Circular Economy to Manufacture Sneakers from Banana Pseudostem Yarn" (CONIITI 2024). His research interests include machine learning, innovation management, lean manufacturing, pyrolysis technology, circular economy, clean energy, sustainable environmental management, and business competitiveness.

SILVIA PONCE ÁLVAREZ

Silvia Ponce Álvarez holds a PhD in Applied Physical Chemistry from Universidad Autónoma de Madrid and a Bachelor's degree in Chemistry from Universidad Nacional Mayor de San Marcos. She completed her doctoral thesis at Instituto de Catálisis y Petroleoquímica (CSIC, Spain). She has carried out postdoctoral research at Institut für Angewandte Chemie (ACA-Berlin, Germany), Universidad de Buenos Aires (Argentina), Universidad Autónoma de Madrid (Spain), and Auburn University (United States), and was a fellow of AECI-ICI (Spain) and DAAD. She leads the research groups on Applied Nanomaterials and Circular Economy. She has participated as principal investigator and co-investigator in research projects funded by ProCiencia, PNIPA, Innovate Peru, TWAS, and UNESCO-L'Oréal, among others. She serves as an external evaluator of projects funded through competitive grants from FONDECYT, UNMSM, and PUCP, and as a reviewer for journals indexed in Scopus and Web of Science. She is the recipient of the For Women in Science 2013-Peru Award, Green Patent 2022, General Prize of the Indecopi Contest 2022, Peruvian Inventor Award 2022, and the Silver Medal at KIWIE 2023. Her research interests include nanomaterials derived from agro-industrial waste, heterogeneous and environmental catalysis, photocatalysis, and the removal of aqueous contaminants using non-conventional methods.

Construction Project Delays: Application of Lean Construction for Process Optimization and On-Time Delivery Validated through Simulation

Gustavo Almeida¹ , Stefano Monier² , Silvia Ponce³ , Edilberto Avalos-Ortecho⁴ 

¹20190059@aloe.ulima.edu.pe, ²20172373@aloe.ulima.edu.pe, ³sponce@ulima.edu.pe, ⁴eavalos@ulima.edu.pe

¹²³⁴Carrera de Ingeniería Industrial, Universidad de Lima, Perú

Received: August 15, 2025 / Accepted: September 10, 2025 / Published: 5 June, 2026

doi: <https://doi.org/10.26439/ciii2025.8652>

ABSTRACT—Construction projects in Peru often face delays that result in economic and contractual penalties. This study identifies the primary causes of project delays and proposes a process optimization model based on Lean Construction tools, applied to a road maintenance company. The methodology combines exploratory and experimental phases using operational data from 2022–2023. Pareto analysis and the 5 Whys technique identify material shortages (52%) and requisition rework (31%) as the most critical contributors to delays. To mitigate these issues, the Last Planner System, Standard Work, and Kaizen are implemented. Validation using discrete-event simulation in Arena demonstrates a 24.69% increase in project physical progress, a 39.27% reduction in accumulated delay days, and a 65.96% decrease in canceled requisitions. These results demonstrate that Lean tools can significantly improve planning reliability, reduce rework, and promote a continuous improvement culture in public works.

Index Terms—Delay analysis, Last Planner System, Lean construction, material supply disruptions, planning management, simulation modeling, Standard Work.

I. INTRODUCTION

The construction industry faces recurring challenges related to delays in project delivery, resulting in economic, contractual, and social losses in both public and private works [1]. A case study revealed that, in a residential project, up to 132 days of extensions were granted, of which 75 days were directly attributed to the effects of the 2011 revolution, highlighting the tangible impact of external factors on project schedules. Studies conducted in Malaysia indicate that inadequate site management and changes during execution are among the primary causes of project delays [2], [3].

One of the current tools with the greatest impact in project management is Building Information Modeling

(BIM). Its application improves transparency, coordination among stakeholders, and resource allocation efficiency, especially in public works projects. A BIM-based partnership framework has been proposed in [4], highlighting that its integration facilitates collaborative decision-making, reduces contractual conflicts, and improves planning throughout the project life cycle. Although advances using tools such as the Last Planner System (LPS) and Kaizen have been documented, the literature shows limitations regarding their integrated application and quantitative validation in Peruvian public companies.

In response to this problem, Lean methodologies such as the LPS have been adopted. LPS enables collaborative planning, prerequisites management, and improved schedule reliability. However, in contexts where LPS is not yet systematically applied, it has been reported that on average only 54% of weekly planned tasks are completed as scheduled, revealing a critical gap between planning and execution [5]. In contrast, the literature documents that, despite approximately 50% of tasks being completed ahead of schedule, one company was able to sustain a Percent Plan Complete (PPC) between 80% and 90%, owing to its capability to adequately prepare tasks and resolve operational constraints during the execution week [6].

Other Lean tools, such as Standard Work, have been applied to reduce operational variability through the standardization of critical tasks. The literature highlights that its implementation, when combined with collaborative practices, improves operational efficiency [7]. Likewise, a case study reported that its application reduced the work cycle by 31.6 seconds, resulting in a 6.5% increase in productivity. These results demonstrate that operational standardization contributes to improved management performance without requiring major technological investments.

According to the continuous improvement approach, the Kaizen philosophy has shown positive results in construction contexts. The study [8] documents its successful application in social housing projects where, after

implementing actions through the “seven forms” tool, quantifiable improvements were achieved: an 18% reduction in scaffolding activities, 11% in internal formwork, and 50% in concrete pouring. These results reflect a direct impact on time, cost, and labor load, evidencing Kaizen’s potential to optimize processes and establish a culture of continuous improvement in construction works.

This research aims to identify the most significant causes of delays in construction project execution in Peru and to propose a Lean-based process optimization model, emphasizing collaborative planning, operational standardization, and continuous improvement. The article is organized into four sections. Section I introduces the problem and presents the theoretical framework. Section II describes the methodology employed. Section III presents and discusses the results. Finally, Section IV provides the conclusions derived from the analysis. Therefore, this research poses the following question: What Lean construction-based management tools can be applied to reduce delays and improve reliability in public construction projects?

II. METHODOLOGY

A. Initial Diagnosis

This study is framed as applied exploratory research, with a quantitative approach followed by an experimental phase, using data collected from the road maintenance company regarding its performance during the 2022–2023 period.

The company under study experiences recurrent net profit losses due to low efficiency in meeting client-established deadlines. To address this issue, an initial diagnostic analysis was conducted using tools such as a Pareto diagram and the 5 Whys technique, enabling a focused examination of the primary problem drivers. As shown in Table I, penalties associated with delayed deliveries significantly affect the company’s financial performance, underscoring the urgent need to improve project scheduling and execution processes [9].

A Pareto diagram, shown in Fig. 1, was developed to identify the key factors contributing to the high rate of project noncompliance. This analysis was based on quantitative data collected from personnel with at least six months of experience working in construction sites, logistics, warehousing, and procurement.

The main results identified material shortages (52%) and rework in material requisitions (31%) as the most critical factors. The application of this tool provides a reliable basis for an in-depth analysis of the most urgent requirements for effective project execution [10]. In most cases within the sector, these issues are typically attributed to inadequate project planning and management practices [11]. However, it is essential to identify the underlying root causes behind these incidents.

TABLE I
PENALTY TABLE

Project	Production (S/)	Delay (days)	Penalty (S/)
1	1,207,033	28	57,477.76
2	2,800,902	42	66,688.14
3	2,402,459	39	61,601.51
4	3,646,211	41	88,931.98
5	4,200,344	35	120,009.83
6	1,409,400	44	32,031.82
7	2,900,177	25	145,008.85
8	2,102,655	38	55,333.03
9	3,200,000	43	74,418.60

TABLE II
MAIN CAUSES OF MATERIAL SHORTAGES

Problem	Frequency	Percentage
Lack of foresight in the request and coordination of materials by the construction team	30	48.4%
Lack of standardization in the process of formulating the requirement	32	51.6%
Total	62	100%

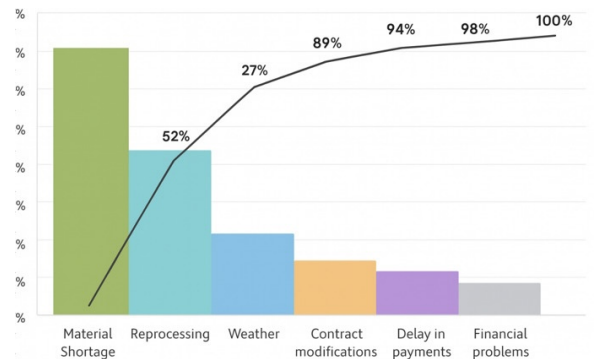

Fig. 1. Pareto diagram for identifying the causes of project delays.

In the case of material shortages, a process flowchart was created to identify the reasons underlying the scarcity of construction materials. This tool enabled a visual and structured identification of errors, allowing the determination of their root causes.

The main causes of material shortages underscore the urgent need to improve planning and provisioning processes. More than 50% of the issues are related to field personnel, suggesting the necessity of implementing a management system that enhances forecasting and coordination among teams, as shown in Table II.

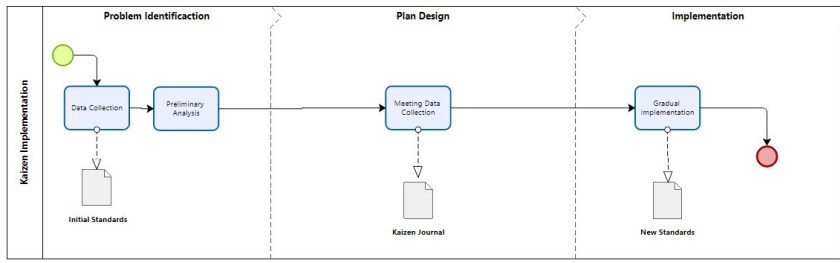

Fig. 5. Kaizen implementation.

Based on the analysis of historical records of canceled requisitions, it was inferred that the tools selected for solution design should focus on enhancing field management and standardizing the material requisition process.

Regarding the identification of root causes for material requisition rework, records of 129 logistical requisitions generated in 2023 were analyzed using the 5 Whys technique. The main finding was the absence of a standardized requisition format, as requests were frequently submitted using technical language that was not clearly understood by other departments involved in the workflow, as shown in Fig. 2.

Based on the above findings, it was determined that, rather than merely improving existing processes, the company requires a new management model that fosters effective inter-departmental interaction. To this end, the implementation of Lean Construction tools was selected, as their application has been shown to have a positive overall impact on project planning and execution, as illustrated in Fig. 3 [12].

The KPIs to be influenced were calculated using historical reports provided by the company and will be the primary metrics considered to measure the impact of the implementation, as shown in Fig. 4.

B. Solution Design

The management model should be implemented progressively and accompanied by continuous monitoring, as the Lean Construction philosophy often encounters barriers such as resistance to change and limited engagement stemming from an incomplete understanding of the long-term added value it generates [13]. The tools used were as follows:

- 1) Kaizen: Weekly meetings were held among the involved departments to encourage the reporting of problems, incidents, and recommendations related to specific process activities, thereby fostering transparent communication and enabling the early detection of potential negative impacts on the implementation of other tools involved in the case study. As reported in [8], regular interdisciplinary meetings facilitate the identification and resolution of process inefficiencies, contributing to enhanced project outcomes and collaboration in construction projects, as shown in Fig. 5.

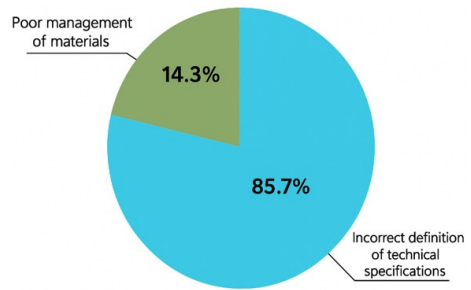

Fig. 2. Distribution of canceled requisitions in the warehouse.

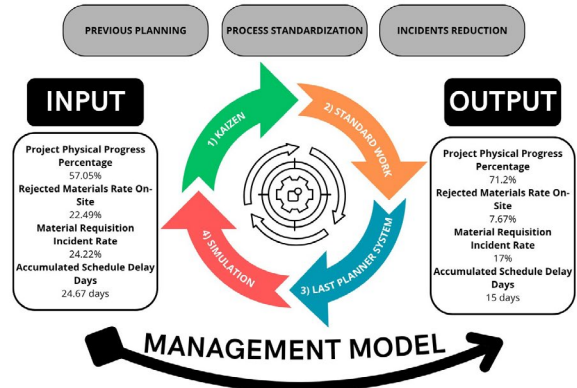

Fig. 3. Proposed model.

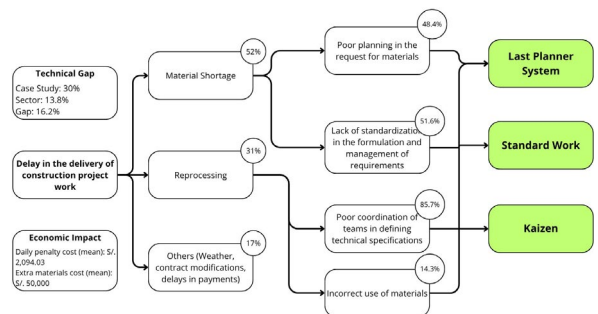

Fig. 4. Problem tree.

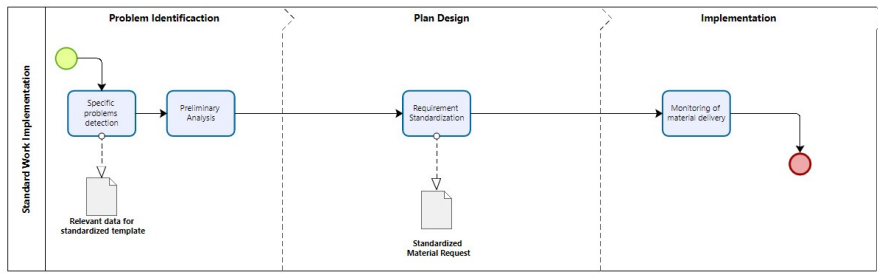

Fig. 6. Standard Work implementation.

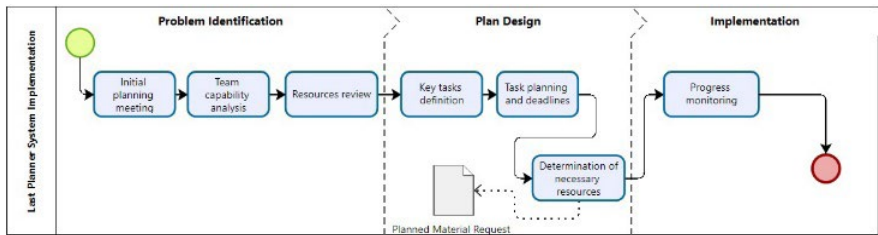

Fig. 7. LPS implementation.

- 2) Standard Work: Operational standards were established for the preparation and approval of logistical requisitions to reduce technical errors and variability in documentation quality. These standards included structured forms and clearly defined validation sequences, aiming to significantly reduce rework rates. This aligns with [14], which emphasizes that standardizing logistics documentation—particularly in international contexts—reduces verification time, minimizes errors, and simplifies cargo handling procedures. The study further highlights that the lack of standardization remains a major obstacle due to system fragmentation, multilingual requirements, and the involvement of multiple intermediaries across the supply chain, as shown in Fig. 6.
- 3) Last Planner System (LPS): Through a combination of collaborative planning, constraint management, and progress monitoring using indicators, this tool aims to continuously improve the performance of construction projects, as shown in Fig. 7.

III. RESULTS

A. Arena Simulation

The improvements introduced by the management model were validated to determine their impact on the KPIs. The key areas involved in the management flow and the transformation of material requirements were modeled within the simulation environment. Specifically, the

warehouse area is represented in Fig. 8, the procurement and logistics area in Fig. 9, and the construction execution in Fig. 10.

The KPIs to be evaluated were simulated using modules, variables, and other complementary outputs, which enabled the automatic generation of the aforementioned KPIs in the results report produced by the Arena software, as shown in Table III.

Additionally, three hypothetical scenarios were developed representing different levels of implementation impact, with the aim of analyzing the model's robustness to variations and capturing the inherent uncertainty of real execution conditions.

- 1) Expected: Tools implemented in the baseline scenario, influencing in accordance with the projected outcomes.
- 2) Optimistic: The implementation is positively adopted by the affected areas, enabling the tools to achieve their maximum performance.
- 3) Pessimistic: Due to risk factors inherent to the construction sector, the measured impact of the implementation is reduced by 25%.

B. Project Physical Progress Percentage

When comparing the baseline model with the model incorporating the implemented tool, no overlap was observed between the confidence intervals of the evaluated scenarios, indicating a statistically significant improvement—at a 95% confidence level—in the on-site progress of the project.

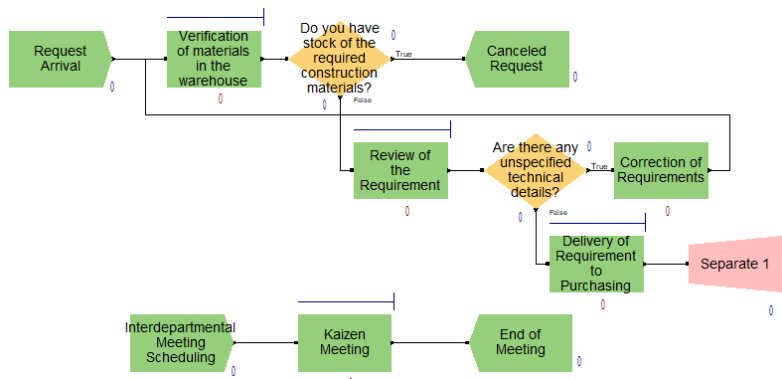

Fig. 8. Warehouse area simulation.

TABLE III
SIMULATION OUTPUT RESULTS

Output summary for 30 replications

Identifier	Average	Half-width	Minimum	Maximum
Project physical progress percentage	71.22%	0.85%	67.31%	75%
Rejected materials rate on-site	7.72%	1.17%	1.43%	14.52%
Material requisition incident rate	19.4%	1.15%	13.92%	30.95%
Accumulated schedule delay days	14.684	1.8096	8.6699	25.356

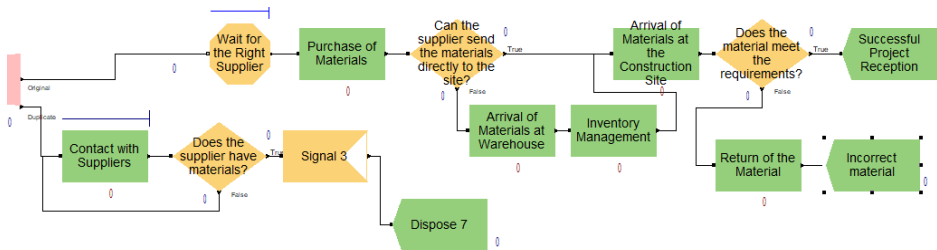

Fig. 9. Supply and logistics area simulation.

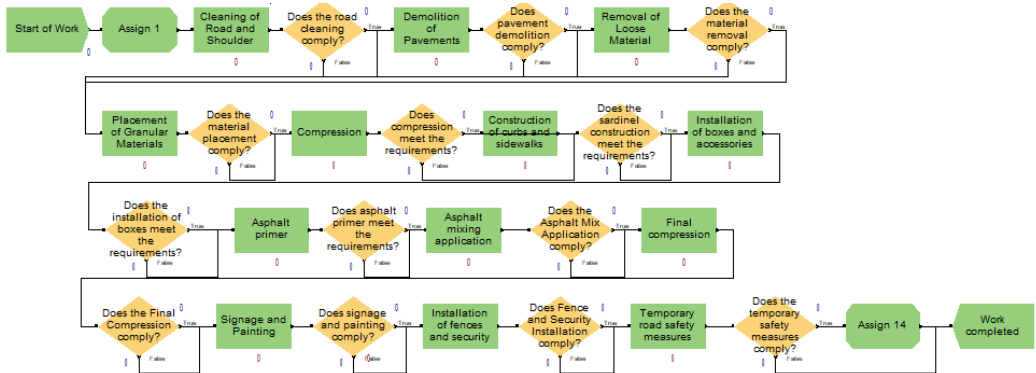

Fig. 10. Work in progress simulation.

As a main result, the implementation of the management model reduced the durations of critical tasks which, on average, were delayed 78.63% of the time, as shown in Table IV.

In addition, the number of material requisitions generated per month decreased by 48.54%, as shown in Fig. 12.

C. Accumulated Schedule Delay Days

The statistical analysis shows no overlap between the baseline and improved scenarios, indicating a significant and measurable reduction in the number of delay days relative to the initial state.

In the AS-IS model, an average of 24.7 accumulated delay days was recorded, while in the TO-BE model this decreased to 15 days, representing a 39.27% reduction.

This improvement aligns with the expected benefits of implementing the LPS, which is well documented for enhancing team coordination and optimizing task execution sequencing [15]. By promoting realistic commitments and tracking collaborative progress, the LPS tool contributes to greater reliability in activity scheduling, as shown in Table V.

Additionally, the economic impact associated with the delay was estimated by quantifying the contractual penalty, based on the daily penalty formula used by the client:

$$Penalization = \frac{0.1 * (Project Amount)}{0.4 * (Days of Delay)}$$

This difference represents a direct saving of S/ 20,312.13 per project delivered, attributable to the reduction in accumulated delays. This result highlights the operational profitability of applying collaborative planning systems in medium-scale construction projects.

D. Rejected Materials Rate On-Site

With a 48.54% reduction in the number of on-site requisitions and a 20% decrease in the incidence rate related to technical specifications in the warehouse area, a considerable improvement in this KPI was observed.

In addition, the interruption index—calculated as the proportion of scheduled time lost due to on-site material shortages—showed a significant improvement of 68.59%, as shown in Table VI.

To evaluate the effect of systematic improvement on the duration of on-site activities, the two simulated scenarios were compared. In the improved scenario, an approximate 20% reduction was applied to the duration of value-added (VA) activities, while preserving the sequential logic, which could not be altered, as shown in Table VII.

In the current scenario, the total process time is 37.08 days, of which 28.25 correspond to VA activities and 8.83 to non-value-added (NVA) activities. It is important to note that, although NVA activities do not directly transform the final product, they are required to enable the execution of the main tasks.

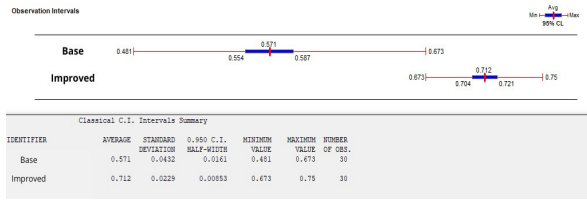

Fig. 11. Output analyzer of project physical progress percentage.

TABLE IV
COMPARISON TABLE

	Project physical progress percentage	Critical tasks
Base model	57.1%	4
Improved model	71.2%	0
Improvement	24.69%	100%

Note: Critical tasks are construction activities with a delay incidence rate of more than 65% (standard for the case study).

TABLE V
COMPARISON OF MODELS

	Accumulated schedule delay days	Average (S/)
Base model	24.7 days	51,722.65
Improved model	15 days	31,410.52

Note: For the penalization calculation, historical case study data were used, excluding construction projects with durations shorter than 30 days.

TABLE VI
COMPARISON OF MODELS

	Rejection rate of materials on site	Interruption index
Base model	22.5%	32.53%
Improved model	7.72%	10.22%
Improvement	65.7%	68.59%

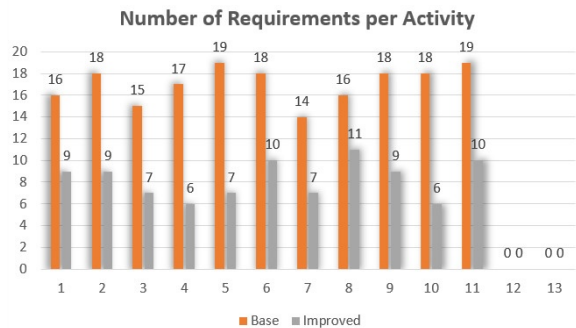

Fig. 12. Number of requisitions per activity.

Note: Activities 12 and 13 were not scheduled with requisitions as they do not involve construction materials.

TABLE VIII
SCENARIOS COMPARISON

KPI	Base	Pessimistic	Expected	Optimistic
Project physical progress percentage	57.05%	59.3%	71.2%	72.2%
Accumulated schedule delay days	24.67 days	16.2 days	15 days	8.01 days
Rejected materials rate on-site	22.49%	11.03%	7.72%	3.63%
Material requisition incident rate	24.22%	19.78%	17%	10.99%

In contrast, in the improved scenario, the total process time is reduced to 29.70 days, consisting of 22.63 days of VA time and 7.07 days of NVA time. This reduction reflects a positive impact on process timelines, as shown in Fig. 9.

E. Material Requisition Incident Rate

The implementation of Standard Work resulted in a significant decrease in the average value of the analyzed KPI, from 0.242 to 0.170, representing an improvement of 29.75%.

It is crucial to highlight the improvement in the number of canceled requisitions, which decreased by 65.96% following the implementation. Efficient management of material requisitions is a critical pillar for the smooth execution of projects at all stages, as it requires coordination across multiple functional areas. Additionally, a substantial drop in canceled requisitions was observed, corresponding to a 65.96% reduction, as shown in Fig. 10. This metric is particularly relevant, as each canceled requisition represents a loss of operational time, generates administrative rework, and in many cases, directly delays on-site construction activities.

F. Scenario Analysis

In order to evaluate the sensitivity of the proposed model under different adoption conditions, a multi-scenario analysis was conducted, including the improved model, as well as pessimistic and optimistic scenarios.

These configurations represent, respectively, low, expected, and high levels of adherence to the implemented Lean tools, allowing the observation of result variability under different execution conditions, as shown in Table VIII.

From a comparative approach, statistically significant differences were identified across all simulated KPIs when compared to the baseline model. The project physical progress percentage exhibited an increasing trend according to the level of implementation: starting at 57.05% in the baseline scenario, rising from 59.3% (pessimistic), 71.2% (expected), and 72.2% (optimistic). This evolution represents a cumulative relative improvement of up to 26.5% compared to the reference scenario.

Regarding accumulated schedule delay days, a progressive reduction was observed, decreasing from 24.67 days in the baseline model to 16.2, 15.0, and 8.01 days in the

TABLE VII
COMPARISON OF VA, NVA, AND TOTAL TIMES BETWEEN THE CURRENT AND IMPROVED SCENARIOS

Indicator	Base model	Improved model	Improvement (%)
VA time	28.25 days	22.63 days	-19.9%
NVA time	8.83 days	7.07 days	-19.5%
Total time	37.08 days	29.7 days	-19.7%

Note: Reference time based on 1 km of roadway.

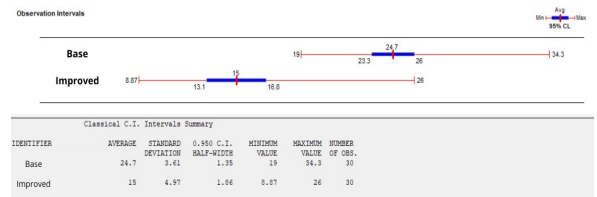

Fig. 13. Output analyzer of accumulated schedule delay days.

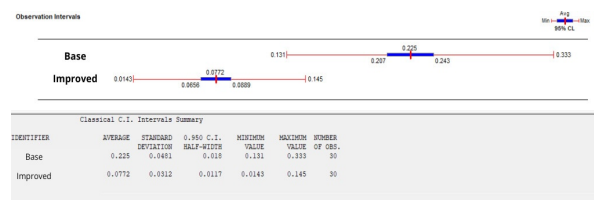

Fig. 14. Output analyzer of rejection rate of materials on site.

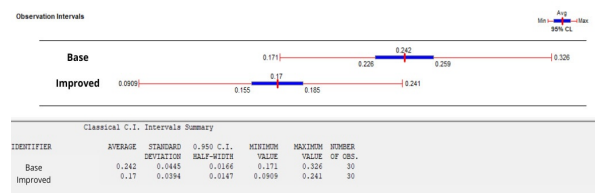

Fig. 15. Output analyzer of material requisition incident rate.

three scenarios, respectively. This reflects a reduction of up to 67.5% in the most favorable scenario, demonstrating a high positive sensitivity of the model to improvements in planning and operational control (LPS).

In addition, logistics-related indicators also showed significant decreases. The rate of materials rejected on-site decreased from 22.49% to 11.03%, 7.72%, and 3.63%, corresponding to improved standardization processes and technical control. Simultaneously, the incidence rate of material requisition errors—defined as the percentage of requisitions with technical or administrative errors—declined from 24.22% to 19.78%, 17.0%, and 10.99%, evidencing a reduction of up to 54.64% relative to the baseline model.

Overall, this analysis demonstrates that the proposed model exhibits robust consistency under varying operational conditions and that the magnitude of KPI improvements is directly proportional to the level of implementation achieved.

IV. DISCUSSION

The results obtained confirm that an integrated Lean model can generate significant improvements in the planning and execution of construction projects in the public-sector construction projects. The implementation of the model led to a 24.69% increase in physical progress and the elimination of 100% of critical tasks, which in the baseline scenario had a delay incidence rate of 78.63%. These results reflect a tangible improvement in operational coordination, consistent with the positive impacts of Lean construction tools on schedule reliability and planning discipline reported in [15].

A physical progress increase of 24.69% exceeds the 18% improvement documented in [8], highlighting the enhanced effect of combining Lean tools into a unified management model.

In terms of delay reduction, this study achieved a 39.27% decrease in accumulated delay days, which surpasses the 25% improvement observed in [15] through the implementation of the LPS in public works.

As discussed in [16], Lean practices improve production control by fostering commitment-based planning and continuous monitoring through PPC metrics. The current study supports these findings by showing reduced rework and better task coordination. However, unlike the task-specific applications addressed in [8], the proposed approach integrates Lean tools at the interdepartmental level, contributing to a 65.96% reduction in canceled requisitions.

The application of Standard Work proved decisive in reducing ambiguities and documentation errors. While [7] described qualitative benefits from standardization, this study adds quantitative evidence, with a 29.75% reduction in requisition incident rate and a 68.59% improvement in the interruption index.



Fig. 16. Material requisition requests.

Model validation was conducted using Arena-based probabilistic simulation, with a confidence interval $\leq 5\%$, confirming the statistical significance of the improvements. Unlike the approach in [16], which used basic simulation for residential projects, the present model incorporates baseline, pessimistic, expected, and optimistic scenarios, improving robustness and capturing performance variability.

Despite the positive outcomes, fluctuations in non-productive time were observed, potentially influenced by external factors such as weather and equipment availability. As indicated in [11], many delays and cost overruns in construction projects stem from causes beyond the contractor's control, such as logistical interference and supply issues. Therefore, even effective Lean models should be complemented by strategies to mitigate contextual risks.

Resistance to change was observed during implementation, attributable to limited knowledge of Lean construction and a weak collaborative culture. Similar barriers were identified in [17] and [18], where lack of awareness and low leadership involvement hindered adoption in emerging markets. Overcoming such resistance requires structured training and gradual cultural adaptation.

V. CONCLUSIONS

In conclusion, the integrated model—based on collaborative planning, standardization, and continuous improvement—effectively addresses common challenges such as low productivity, rework, and logistical inefficiencies in public sector projects. Its progressive and non-disruptive implementation strategy proved suitable for organizations with low Lean maturity, enabling cultural alignment and measurable improvements without major investments.

This approach strengthens internal capabilities, fosters continuous improvement culture, and offers a replicable model for other public infrastructure contexts. Finally, this study provides a practical solution for sector professionals, optimizing resources and processes, and offers empirical evidence on the effectiveness of Lean construction in public-sector environments. It also opens new research avenues in sustainability, scalability, and

cultural change, recommending exploration of the model's evolution and its application in different project types with varying levels of Lean maturity.

REFERENCES

- [1] R. F. Aziz, "Ranking of delay factors in construction projects after Egyptian revolution," *Alexandria Eng. J.*, vol. 52, no. 3, pp. 387–406, Sep. 2013, doi: 10.1016/j.aej.2013.03.002.
- [2] J. B. H. Yap, P. L. Goay, Y. B. Woon, and M. Skitmore, "Revisiting critical delay factors for construction: Analysing projects in Malaysia," *Alexandria Eng. J.*, vol. 60, no. 1, pp. 1717–1729, Feb. 2021, doi: 10.1016/j.aej.2020.11.021.
- [3] S. A. M. Elsherbiny, S. A.-F. Gad, and A. M. A. Alim, "Critical delay factors in construction projects and their proposed solutions from the perspective of total quality management," *Int. J. Eng. Trends Technol.*, vol. 72, no. 2, pp. 1–8, Feb. 2024, doi: 10.14445/22315381/IJETT-V72I2P101.
- [4] A. Porwal and K. N. Hewage, "Building Information Modeling (BIM) partnering framework for public construction projects," *Autom. Constr.*, vol. 31, pp. 204–214, May 2013, doi: 10.1016/j.autcon.2012.12.004.
- [5] Buildots. "Percent Plan Complete (PPC)." Buildots Blog. [Online]. Available: <https://buildots.com/blog/percent-plan-complete/>
- [6] F. R. Hamzeh and O. Z. Aridi, "Modeling the Last Planner System metrics: A case study of an AEC company," in *Proc. 21st Annu. Conf. Int. Group Lean Constr.*, Fortaleza, Brazil, Jan. 2013, pp. 599–608, doi: 10.13140/2.1.3852.5121.
- [7] R. Fulford and C. Standing, "Construction industry productivity and the potential for collaborative practice," *Int. J. Project Manage.*, vol. 32, no. 2, pp. 315–326, Feb. 2014, doi: 10.1016/j.ijproman.2013.05.007.
- [8] J. P. P. Vieira, B. M. B. da Silva Etges, R. A. Pellegrino, M. A. Lins, and L. L. Costa, "Kaizen as an improvement method for concrete walls construction in social housing project," in *Proc. 30th Annu. Conf. Int. Group Lean Constr. (IGLC)*, Edmonton, AB, Canada, 2022, pp. 354–365, doi: 10.24928/2022/0136.
- [9] M. I. Ahmed and S. E. Rezouki, "Application of root causes analysis techniques in the contractor selection for highway projects," in *IOP Conf. Ser.: Mater. Sci. Eng.*, vol. 901, Sep. 2020, doi: 10.1088/1757-899X/901/1/012031.
- [10] S. Shrivastava, M. Jain, and K. K. Pathak, "Pareto analysis of causes of delay and recommendations for training needs," *Int. J. Constr. Project Manage.*, vol. 13, no. 2, 2021. [Online]. Available: <https://www.researchgate.net/publication/362208823>
- [11] T. Al Amri and M. Marey-Pérez, "Towards a sustainable construction industry: Delays and cost overrun causes in construction projects of Oman," *J. Project Manage.*, vol. 5, no. 2, pp. 87–102, Jan. 2020, doi: 10.5267/j.jpm.2020.1.001.
- [12] E. N. Shaqour, "The impact of adopting Lean construction in Egypt: Level of knowledge, application, and benefits," *Ain Shams Eng. J.*, vol. 13, no. 2, Mar. 2022, doi: 10.1016/j.asej.2021.07.005.
- [13] W. Albalkhy and R. Sweis, "Barriers to adopting Lean construction in the construction industry: A literature review," *Int. J. Lean Six Sigma*, vol. 12, no. 2, pp. 210–236, May 2021, doi: 10.1108/IJLSS-12-2018-0144.
- [14] D. Mishchenko, I. Shevchenko, D. Babinin, A. Vdovichen, and O. Verstiak, "Standardisation of data in logistics and business operations," *Multidiscip. Rev.*, vol. 7, p. 2024spe006, Jun. 2024, doi: 10.31893/multirev.2024spe006.
- [15] O. Warid and K. Hamani, "Lean construction in the UAE: Implementation of Last Planner System®," *Lean Constr. J.*, vol. 2023, pp. 1–20, Dec. 2023, doi: 10.60164/96f4a5e0g.
- [16] H. Erol, I. Dikmen, and M. T. Birgonul, "Measuring the impact of Lean construction practices on project duration and variability: A simulation-based study on residential buildings," *J. Civ. Eng. Manage.*, vol. 23, no. 2, pp. 241–251, Feb. 2017, doi: 10.3846/13923730.2015.1068846.
- [17] G. Garcés, E. Forcael, C. Osorio, K. Castañeda, and O. Sánchez, "Systematic review of Lean construction: An approach to sustainability and efficiency in construction management," *J. Infrastruct. Preserv. Resil.*, vol. 6, no. 1, Jan. 2025, doi: 10.1186/s43065-025-00119-1.
- [18] S. Moradi and P. Sormunen, "Implementing Lean construction: A literature study of barriers, enablers, and implications," *Build.*, vol. 13, no. 2, p. 556, Feb. 2023, doi: 10.3390/buildings13020556.

BIOGRAPHICAL NOTES

GUSTAVO ALESSANDRO ALMEIDA ROSILLO

Gustavo Alessandro Almeida Rosillo holds a Bachelor's degree in Industrial Engineering from Universidad de Lima. His areas of interest include data science, production systems engineering, and project management.

STEFANO FRANCO MONIER PEREZ

Stefano Franco Monier Perez holds a Bachelor's degree in Industrial Engineering from Universidad de Lima. He is

currently a professional management intern at Claro Perú. His areas of interest include data science, production process management, and quality engineering.

SILVIA PONCE ÁLVAREZ

Silvia Ponce Álvarez holds a PhD in Applied Physical Chemistry from Universidad Autónoma de Madrid and a Bachelor's degree in Chemistry from Universidad Nacional Mayor de San Marcos. She completed her doctoral thesis at Instituto de Catálisis y Petroleoquímica (CSIC, Spain). She has carried out postdoctoral research at Institut für Angewandte Chemie (ACA-Berlin, Germany), Universidad de Buenos Aires (Argentina), Universidad Autónoma de Madrid (Spain), and Auburn University (United States), and was a fellow of AECI-ICI (Spain) and DAAD. She leads the research groups on Applied Nanomaterials and Circular Economy. She has participated as principal investigator and co-investigator in research projects funded by ProCiencia, PNIPA, Innovate Peru, TWAS, and UNESCO-L'Oréal, among others. She serves as an external evaluator of projects funded through competitive grants from FONDECYT, UNMSM, and PUCP, and as a reviewer for journals indexed in Scopus and Web of Science. She is the recipient of the For Women in Science 2013-Peru Award, Green Patent 2022, General Prize of the Indecopi Contest 2022, Peruvian Inventor Award 2022, and the Silver Medal at KIWIE 2023. Her research interests include nanomaterials derived from agro-industrial waste, heterogeneous and environmental catalysis, photocatalysis, and the removal of aqueous contaminants using non-conventional methods.

EDILBERTO MIGUEL AVALOS ORTECHO

Edilberto Miguel Avalos Ortecho holds a PhD in Business Management from Universidad Nacional Mayor de San Marcos, an MBA in Strategic Business Management from Centrum Católica, and a Master's degree in Environmental Management and Administration from EOI Escuela de Organización Industrial, Spain. He is Coordinator of Research and Publications, Researcher, and Lecturer in the Industrial Engineering Program at Universidad de Lima. He is registered in Renacyt at Level VI under code P0041763 and represents Peru on the ISO/TC 279 Technical Committee on Innovation Management. He has co-authored the publications "Implementation of Lean Manufacturing to Increase Aircraft Availability" (Journal of Fluid Flow, Heat and Mass Transfer); "Crude Oil Production and Simulation from Catalytic Fast Pyrolysis of Waste Polyethylene Terephthalate (PET)" (Cleaner Engineering and Technology, 2025); "Implementation of Machine Learning and BPM to Increase Profitability in a Travel Agency" (World Congress on Mechanical, Chemical, and Material Engineering, 2025); "Application of Lean Manufacturing to Increase Productivity in the Food Sector" (LACCEI 2025); and "Application of Circular Economy to Manufacture Sneakers from Banana Pseudostem Yarn" (CONIITI 2024). His research interests include machine learning, innovation management, lean manufacturing, pyrolysis technology, circular economy, clean energy, sustainable environmental management, and business competitiveness.

Vibe Coding Applications for Industrial Safety

Michael Dorin¹ , Juan M. Machuca De Pina² 

¹mike.dorin@stthomas.edu, ²jmachuca@ulima.edu.pe

¹School of Software Engineering and Data Science, University of St. Thomas, St. Paul, MN, USA

²Carrera de Ingeniería Industrial, Universidad de Lima, Perú

Received: August 15, 2025 / Accepted: September 19, 2025 / Published: 5 June, 2026

doi: <https://doi.org/10.26439/ciii2025.8653>

ABSTRACT—This paper explores the practicality of vibe coding for industrial engineering applications. Specifically, it investigates whether vibe coding can be utilized to create a safety-related application. In industrial environments, many occupations involve physical labor or the operation of potentially hazardous machinery, raising significant concerns regarding worker health and safety. Although various tools and applications exist to address these risks, they are often overly generic and may not adequately meet the specific requirements of individual organizations. The advent of artificial intelligence (AI) and machine learning has transformed this landscape. This study demonstrates how vibe coding can be used to develop a simple Android-based application that leverages built-in sensors—such as sound, light, and accelerometers—to monitor workers’ physical activities and track environmental conditions for accident prevention. It is expected that this work will encourage companies engaged in physical labor to develop customized applications aimed at improving worker safety. Beyond this specific prototype, the proposed approach illustrates how AI-driven coding can bridge the gap between generic safety solutions and tailored workplace applications.

Index Terms—Application, artificial intelligence, industrial, safety, vibe coding.

I. INTRODUCTION

This research explores the practicality of applying the emerging programming paradigm known as vibe coding to industrial engineering applications [1]. This topic is essential because industrial institutions have specific needs that are not fully addressed by standard commercial off-the-shelf (COTS) software [2]. Given that worker safety is a critical priority across all industries, this research examines whether vibe coding can support the rapid development of

customized safety-related applications tailored to specific operational environments.

Underscoring the importance of safety-related software applications, major academic databases such as Scopus, Web of Science, the Association for Computing Machinery (ACM), and Google Scholar have indexed thousands of publications on worker safety since 2024. In particular, Google Scholar reports more than 20,000 articles addressing vibration exposure, over 40,000 studies focused on sound-related risks, and more than 18,000 publications examining bright working conditions [3]. As demonstrated by Nouri et al., this literature search reveals that large language models (LLMs) are being used for safety analysis [4]. The literature review further indicates that numerous technological applications in occupational safety employ virtual reality or simulation-based training to reduce errors and prevent accidents [5]. Although these tools are beneficial during training stages, they cannot monitor the environment during actual operational activities. Zhang et al. have presented an insightful study on a smartphone-based vibration monitoring system [6]. Adverse working conditions can negatively affect worker performance and alertness throughout the workday. Exposure to certain conditions, such as vibrations, is known to cause, at the very least, discomfort or musculoskeletal issues [7]. In contrast, the presence of such technologies contributes to a safer work environment that supports operational excellence and sustainability [8]. Although this study does not specifically focus on worker safety, it demonstrates the potential of mobile devices for vibration management tasks. Feldbusch et al. presented a study on using a network of smartphones to monitor structural vibrations [9]. The authors also effectively demonstrate its applicability to safety-related applications.

Vibe coding is a technique in which software developers use LLMs to generate source code for a desired application. Interaction with LLMs is conducted through what is

commonly referred to as a prompt, which is an instruction or question provided by the user to elicit a specific response [10]. In essence, prompts are the mechanism through which users interact with LLMs. In pure vibe coding, software engineers provide a prompt describing the desired software and rely on the LLM to generate output that works as expected [11]. This application of artificial intelligence enhances the software development experience by automating programming minutiae, allowing developers to focus on more creative aspects of the application under development. While output quality depends on multiple factors, a crucial element is providing appropriate context within the prompt [12]. In the context of AI-driven vibe coding for safety applications, it can be assumed that domain expertise in safety is as valuable as programming skills.

Although vibe coding is a relatively recent phenomenon, researchers have been actively engaged and have published numerous papers on this topic as well. Google Scholar already suggests that more than 10.000 papers have been published [3]. Several authors discuss how vibe coding represents a paradigm shift, where developers focus on refining AI-generated code rather than writing it manually. This is substantially exemplified in an essay by Kreuzbender, which describes his personal experience with the concept [13]. Moore and Tatonetti describe how Vibe coding accelerates application development, reduces software creation cycle times, and reduces the reliance on highly specialized programming skills [14]. Benedetti, a self-described developer with over 40 years of experience, reports a twofold increase in productivity using Vibe coding [15]. Shukla et al. describe the use of LLMs in the pipeline from prototyping to production [16]. While there is considerable optimism regarding vibe coding, some concerns have also been reported. Some critics argue that vibe coding often produces code with insufficient structure, impairing maintainability, and may lead developers to spend more time fixing AI-generated issues than they save. Additional concerns include potential security risks associated with vibe coding, as AI tools may not consistently adhere to best security practices [17].

A number of papers examined the development of mobile applications for worker safety and the monitoring of vibrations. However, these studies do not address the integration of safety applications with vibe coding. This gap is significant: although safety applications and vibe coding have been investigated independently, no research has yet combined them to produce deployable prototypes. This study addresses that gap. Moreover, the concerns raised in previous works regarding vibe coding remain valid and must be considered. Accordingly, this article investigates the application of pure vibe coding to develop a safety application, demonstrating that such applications can be rapidly created for diverse environments.

Several LLMs are capable of performing vibe coding. A useful reference for available tools is the comprehensive list

TABLE I
LLMS AND TOOLS SUITABLE FOR VIBE CODING

Model/Tool	Key strengths
Gemini 2.5 Pro	Multimodal, large context
Claude (Sonnet/Opus/3.7/4)	High quality, long context
GPT-4/GPT-4o	Versatile, multimodal
Llama 3/CodeLlama	Open-source, local
DeepSeek Coder	Coding-optimized
GitHub Copilot	IDE integration
Cursor	Conversational editor
Claude Code (CLI)	Terminal agent
Warp Terminal	NL-to-code Shell
Lovable.com	Rapid prototyping

provided by DigitalOcean, which also outlines the strengths of each model [18]. A summary of this list is presented in Table I. Note that the DigitalOcean list is not exhaustive, as additional tools exist. This research explores vibe coding using Grok from xAI, based on the author's experience with the tool. Grok was selected because it is publicly available, features a conversational interface that facilitates rapid prototyping, and has demonstrated strong performance in software development tasks [19]. A Davis report also supports the choice, highlighting Grok AI's performance in software development and its ability to generate efficient code for complex scenarios [20].

In this research, Grok is used to develop a full-stack application consisting of a Flask back-end and an Android front-end. The results are highly satisfactory. Organizations can adopt the template defined here to create custom safety-related applications.

II. METHODOLOGY

The steps outlined here are not overly complex; programmers are not required to possess advanced engineering skills. Basic programming knowledge and some understanding of software development are sufficient. As the saying goes, "A goal without a plan is just a wish" [21]. This holds true for vibe coding, where a foundational understanding of software development is necessary.

Although several software life cycle models exist, one that stands out for this project is the spiral life cycle. An essential aspect of the spiral life cycle model is risk management, making it a suitable choice for developing a safety-based application. Within the spiral model, the project progresses through multiple iterations, known as spirals, rather than reaching a final product in a single pass. Each spiral consists of several phases: planning, building, evaluating results, and planning the next iteration. If, at

the end of a spiral, risks remain unresolved or there is no clear strategy to address them, the spiral life cycle model requires terminating the project [22]. Spirals can be viewed as iterations of conventional life cycle models, with result evaluation and planning separating each. For instance, each spiral may represent an implementation of the waterfall life cycle model [23].

This study integrates the waterfall model within the spiral framework, as illustrated in Fig. 1. Accordingly, the research commenced with a standard waterfall software development life cycle, in which requirements are defined first, followed by code implementation, and finally testing [24]. These characteristics make the waterfall model well suited for integration with the spiral life cycle. Planning begins with requirements gathering, including the definition of user stories for this project. Each iteration through the spiral produces an improved version of the product.

A. Step 1: Define User Stories

As described in the Introduction, an effective prompt is critical for a vibe coding LLM to generate reliable source code. Explicit prompts are essential because they provide clear, detailed instructions to the AI, ensuring that the generated code aligns as closely as possible with the intended outcome. Accordingly, defining high-quality user stories is a key step in the process.

In this study, the authors initially defined four user stories without the aid of AI, following Ken Beck’s user story format: As a [type of user], I would like to [do something] so that [benefit] [25]. The initial user stories are as follows:

- As a company safety supervisor, I would like to keep track of the vibration experienced by the operators of the machinery of the employees to ensure their health and safety.
- As a company safety supervisor, I would like to keep track of the audio levels experienced by the employees so that appropriate hearing protection can be provided.
- As a company safety supervisor, I would like historical data to be retained so that, in the event of an injury, we can determine how to prevent similar accidents in the future.
- As a safety supervisor, I would like reports displaying audio and vibration data so that trends can be effectively monitored.

B. Step 2: SMART User Stories

Within the waterfall life cycle model, once requirements have been defined and approved, the analysis phase begins [22]. To ensure the best possible prompt, the first step in the vibe coding process is to refine the user stories. To achieve this, the selected LLM, Grok, was tasked with converting the written stories into SMART user stories.

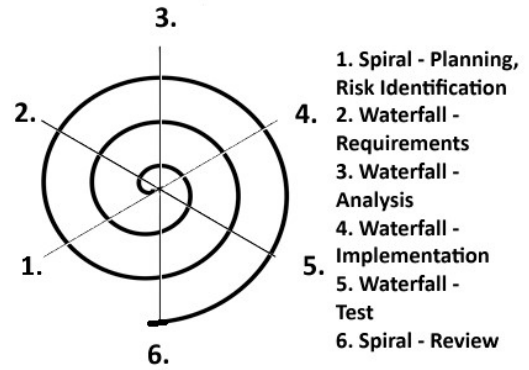

Fig. 1. Hybrid approach blending risk management (spiral) with clear deliverables (waterfall).

TABLE II
FUNCTION-LEVEL METRICS

NLOC	CCN	Function name	File
23	3	onCreate	MainActivity.kt
9	1	(anonymous)	MainActivity.kt
7	3	onResponse	MainActivity.kt
3	1	Run	SensorService.kt
4	1	Run	SensorService.kt
NLOC	CCN	Function name	File
17	2	onStartCommand	SensorService.kt
7	1	onDestroy	SensorService.kt
12	3	onSensorChanged	SensorService.kt
1	1	onAccuracyChanged	SensorService.kt
6	1	startAudioRecording	SensorService.kt
14	3	computeAndSendAudio	SensorService.kt
17	2	sendData	SensorService.kt
7	2	createNotificationChannel	SensorService.kt
10	1	onBind	SensorService.kt

TABLE III
ANDROID METHOD SUMMARY METRICS

NLOC	Avg. NLOC	Avg. CCN	Functions	File
76	13.0	2.3	3	MainActivity.kt
127	8.9	1.6	11	SensorService.kt

SMART is an acronym that guides the creation of well-defined user stories, standing for Specific, Measurable, Achievable, Relevant, and Time-bound. Applying the SMART criteria ensures user stories are precise, emphasizing well-defined outcomes and objectives. In a standard software engineering environment, SMART user stories

enhance team collaboration by providing a clearer understanding of software requirements. For this application, this refinement step ensures that both human and AI share precise expectations, reducing ambiguity and improving the quality of the generated application. Consequently, in vibe coding, the goal is for both the human and the LLM to have a precise understanding of what should be created. Ultimately, SMART user stories contribute to the development of a high-quality prompt. Accordingly, continuing the vibe coding process, human-authored user stories were converted into SMART user stories. The SMART user stories generated by Grok are presented below.

- As a company safety supervisor, I want to monitor vibration levels experienced by machinery operators in real time using sensors that measure vibrations in g-forces with 0.1 g accuracy, integrated with existing machinery, relevant to preventing musculoskeletal disorders, and updated every 5 min during shifts, so that health and safety are ensured by triggering alerts when levels exceed OSHA thresholds.
- As a company safety supervisor, I want to monitor audio levels experienced by employees using decibel meters with 1 dB accuracy via wearable devices synced to a central dashboard, relevant to complying with noise exposure regulations, and monitored continuously during work hours, so that appropriate hearing protection is provided when levels exceed 85 dB for more than 8 h.
- As a company safety supervisor, I want to store historical data on vibrations, audio levels, and related incidents in a secure database for at least 5 years using cloud storage with automated backups, relevant to root cause analysis for injury prevention, and accessible within 24 h of a request, so that if injuries occur, data-driven insights help protect employees from future accidents.
- As a company safety supervisor, I want customizable reports that display audio and vibration trends over selectable time periods (e.g., daily, weekly, monthly), generated through a reporting tool integrated with the data system and presented as charts and graphs, relevant to proactive safety monitoring, and delivered on a scheduled basis via email or dashboard (e.g., weekly), so that emerging trends can be identified and addressed in a timely manner.

C. Step 3: Generate the Code

In the standard waterfall life-cycle model, coding follows the analysis phase. This step also naturally aligns with the vibe coding approach.

The SMART user stories were implemented through Grok's public user interface to generate a new prompt. This prompt requests the development of a full-stack application

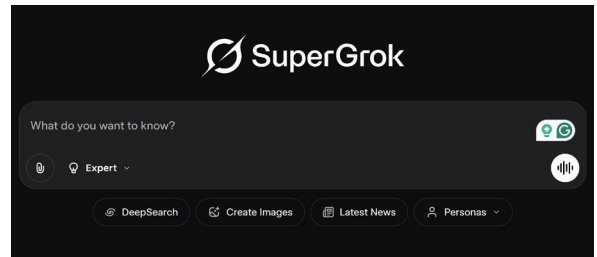

Fig. 2. Grok user interface.

comprising a Flask-based back end [26] and a native Android front end [27]. The Grok user interface is shown in Fig. 2.

For the Android application, Grok generated Kotlin source code consisting of two main classes and a limited set of methods. Similarly, the Flask application, implemented in Python, was concise and lightweight.

D. Step 4: Testing

The final step prior to deployment in the waterfall model is testing. This phase also aligns with the evaluation stage of the spiral model. During testing, the generated application was deployed on an Android device, and the Python-based back end was launched on a server.

III. RESULTS

At the conclusion of each spiral, the process includes evaluating the results and planning the subsequent iteration. Grok generated two projects: an Android application implemented in Kotlin and a Python-based Flask application. The Android application comprised two classes only—`MainActivity` and `SensorService`—with the latter responsible for device sensor monitoring. These components are illustrated in Fig. 3. The Android application was built without syntax errors and successfully launched, as illustrated in Fig. 4. Although the application initially executed without errors, the Android manifest required modification to enable foreground sound monitoring. In addition, the manifest was configured to permit clear-text data transmission for testing purposes, which incidentally highlights a potential security concern. Grok was also tasked with recommending the appropriate manifest modifications.

Upon startup, the Android application displays an interface that allows the entry of an employee identifier and provides a control to initiate monitoring. Once data are available, an additional option is presented to retrieve a report. The monitoring control is not specific to sound or vibration; instead, both sensors are activated simultaneously when the control is triggered. This monitoring supports the requirements established in the user stories; the Android application can monitor sound and vibration.

The ability to retrieve historical data demonstrates support for the reporting requirement. These results illustrate that an operational prototype can be developed within a single development cycle, a task that would typically require significantly more time, effort, and expertise.

Before deployment, two key issues must be addressed: the absence of a stop button and the report presentation format. While continuous monitoring is essential, a stop button is required to allow users to pause data collection and easily retrieve reports. In addition, the current report display on the Android device is too small to be legible. Addressing these issues will improve usability and provide a more effective user experience.

The Flask application generated by Grok was deployed and executed on a Windows system without major issues. The application exposes a RESTful interface for storing audio and vibration data, as well as for retrieving report information. The RESTful endpoints were tested using a PowerShell script based on Invoke-WebRequest commands with the -Method POST option to submit audio and vibration data.

Invoke-WebRequest commands with the -Method GET option were used to retrieve report data. Initial verification and validation testing revealed no apparent errors in the Flask application.

The benefit of the spiral life cycle model is that it addresses risks. The introduction defined two risks. The first risk was that poor-quality code would be generated. Tables IV and Table V show the lines of code per function, as well as the cyclomatic complexity (CCN). While discussing software metrics is not the primary focus of this paper, none of the generated functions exhibit a CCN greater than seven. Cyclomatic complexity values in the range of 10-15 are generally considered problematic and typically require code restructuring [28]. Furthermore, the overall architecture, as illustrated in the class diagrams, does not exhibit excessive code volume or undue complexity.

The second identified risk relates to security. It can be argued that Grok did not generate any code addressing protection or security mechanisms. As the saying goes, computers do not do what is intended, but rather what they are instructed to do; this principle applies equally to vibe coding. In this case, no security requirements were specified in the original user stories, nor was there any indication that security considerations were expected. Consequently, Grok generated code strictly based on the requirements provided.

With this in mind, as part of the planning for the second spiral, Grok was prompted to generate three additional SMART user stories. These include one addressing authentication, one focused on data security, and another covering the missing stop button in the Android user interface. These results are shown below.

- As a company safety supervisor, I want to implement robust encryption for all stored and transmitted

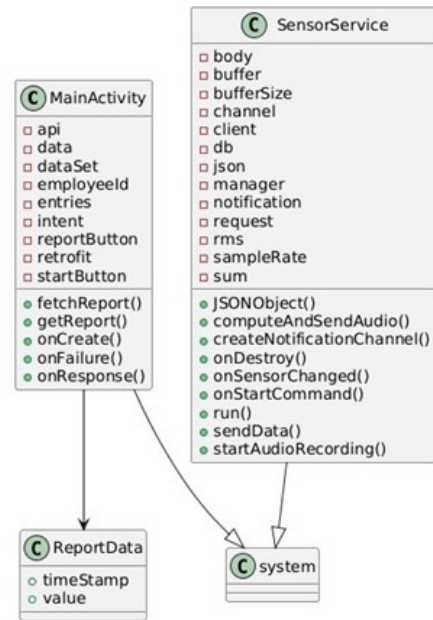

Fig. 3. Android application class diagram.



Fig. 4. Android application showing main menu.

TABLE IV
FUNCTION-LEVEL METRICS

NLOC	CCN	Function name	File
11	2	add vibration	app.py
11	2	add audio	app.py
19	7	get report	app.py

vibration and audio-level data using the AES-256 standard. This can be achieved through integration with secure cloud services such as AWS Key Management Service (KMS), ensuring the protection of sensitive employee health information against unauthorized access. Compliance with data protection regulations, including the Health Insurance Portability and Accountability Act (HIPAA), will be verified through annual penetration testing, thereby safeguarding employee privacy.

- As a company safety supervisor, I want to enforce multifactor authentication (MFA) for all application user logins using methods such as authenticator applications or SMS-based verification. This will be implemented through integration with identity providers such as Okta or Azure Active Directory (Azure AD) to prevent unauthorized access to sensitive health and safety data. MFA will be required for every user session, with automatic logout enforced after 15 min of inactivity, thereby ensuring that only authorized personnel can access the system and that employee data remains protected against potential security breaches.
- As a company safety supervisor, I want to provide a prominent stop/start control at the top of the user interface to manually enable or disable real-time monitoring of vibration and audio levels. This functionality shall be implemented through intuitive user interface controls integrated into the application dashboard, allowing flexible operation during work shifts or maintenance activities. The control shall respond within 1 s of user activation, ensuring that monitoring can be paused or resumed as needed without disrupting operations or data integrity.

The complete set of user stories was subsequently consolidated into a new prompt, which was provided to Grok to generate a next-generation version of the code. This updated version incorporated the required user interface elements, as well as enhanced authentication and security features. The following changes were implemented in the new code build.

- Implement AES-256 encryption for vibration and audio data transmission via HTTPS/TLS 1.3, using libraries such as OpenSSL or Bouncy Castle in backend and Android app.
- Integrate key management, encrypting data before cloud storage and decrypting on retrieval.
- Add automatic logout after 15 min of inactivity using idle timers and session logic in Android app/backend, with secure token storage.
- Add prominent start/stop button in Android app UI (e.g., Button in Toolbar/AppBar) with event listeners to toggle vibration/audio monitoring.

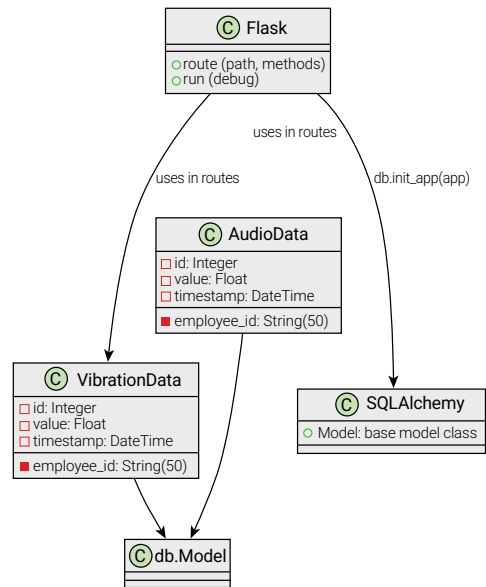

Fig. 5. Flask application class diagram.

TABLE V
FILE-LEVEL SUMMARY METRICS (TWO FILES ANALYZED)

NLOC	Avg. NLOC	Avg. CCN	Function count	File
60	13.7	3.7	3	app.py
13	0.0	0.0	0	models.py

IV. DISCUSSIONS

A. Productivity Benefits

This study demonstrates that vibe coding can be effectively applied to the generation of software applications, including those intended for industrial safety contexts. The Android and Flask applications developed were syntactically correct and closely aligned with the requirements specified by the SMART user stories. This result is significant, as the development of safety-critical applications has traditionally required substantial development effort. The proposed approach leverages AI-driven code generation, indicating that individuals or small teams can achieve high levels of productivity while contributing to operational excellence.

B. Limitations

The successful generation of these applications motivates further research in this area. At a minimum, vibe-coded applications require extensive testing and rigorous review prior to deployment in safety-critical environments. Several

initial implementation issues must also be addressed. For example, the omission of fundamental security features highlights the importance of carefully designed prompts and the need for domain expertise to effectively guide the vibe coding process. The initial results indicate that, while vibe coding significantly increases developer productivity, it does not eliminate the need for thorough verification and validation. Oversight by qualified professionals therefore remains essential.

Future work should focus on expanded testing under realistic operating conditions, the systematic incorporation of user feedback, and the evaluation of alternative LLMs. These efforts should be aligned with applicable safety regulations issued by government agencies, such as the Occupational Safety and Health Administration (OSHA) in the United States [29], as well as with data protection frameworks, including the General Data Protection Regulation (GDPR) of the European Union [30]. In addition, compliance with the HIPAA, which governs the privacy and security of protected health information in the United States [31], should be ensured. Such regulatory alignment is essential to guarantee compliance and to foster trust among workers.

V. CONCLUSIONS

The purpose of this investigation was to determine whether vibe coding could be applied to the development of safety-oriented applications in an industrial environment. The study demonstrated that functional prototypes—specifically, an Android monitoring application and a Flask-based backend—can be rapidly generated using a LLM.

As part of this project, initial user stories were authored by humans. The Grok AI tool was then tasked with transforming them into SMART user stories and generating code for both a Flask-based backend and an Android application. Although some initial tuning was required to obtain a fully functional Android application, Vibe Coding successfully produced code that conformed to the tasks specified in the user stories. Overall, the results clearly indicate that vibe coding significantly increases development productivity. Vibe coding enables small teams—or even individual developers—to create powerful, tailored applications, thereby providing organizations with enhanced tools suited to their specific operational environments. However, despite the significant productivity gains offered by vibe coding, its use should be accompanied by continuous expert human oversight to ensure correctness, safety, and maintainability. Ultimately, vibe coding signifies a significant shift that enables organizations to use their developers more efficiently. More research is needed to enhance the effectiveness of this technique. In addition, the authors of this work envision that similar methods could be applied beyond industrial safety—for example, in specialized healthcare monitoring or logistics—demonstrating the

broader generalizability of vibe coding for the development of safety-critical systems.

Acknowledgments

The authors acknowledge the use of AI-based tools—specifically Grammarly for grammar and language refinement, and Grok for user story and code generation.

REFERENCES

- [1] A. Sarkar and I. Drosos, “Vibe coding: Programming through conversation with artificial intelligence,” 2025, *arXiv:2506.23253*.
- [2] J. Beheshti and J. Dupuis, “Problems with COTS software: A case study,” *Proc. Annu. Conf. CAIS Actes du congrès annuel de l’ACSI*, no. 2000, Oct. 2013, doi: <https://doi.org/10.29173/cais7>
- [3] Google. “Google Scholar.” Google. Accessed: Aug. 5, 2025. [Online]. Available: <https://scholar.google.com>
- [4] A. Nouri, B. Cabrero-Daniel, F. Torner, H. Sivencrona, and C. Berger, “Welcome your new AI teammate: On safety analysis by leashing large language models,” in *Proc. IEEE/ACM 3rd Int. Conf. AI Eng.–Softw. Eng. for AI (CAIN)*, Lisbon, Portugal, Jun. 2024, pp. 172–177, doi: <https://doi.org/10.1145/3644815.3644953>
- [5] O. Flor-Unda *et al.*, “Innovative technologies for occupational health and safety: A scoping review,” *Safety*, vol. 9, no. 2, p. 35, May 2023, doi: <https://doi.org/10.3390/safety9020035>
- [6] D. Zhang, J. Tian, and H. Li, “Design and validation of Android smartphone-based wireless structural vibration monitoring system,” *Sensors*, vol. 20, no. 17, p. 4799, Aug. 2020, doi: <https://doi.org/10.3390/s20174799>
- [7] B. Halmaj, T. P. Holsgrove, S. J. Vine, D. J. Harris, and G. K. Williams, “The after-effects of occupational whole-body vibration on human cognitive, visual, and motor function: A systematic review,” *Appl. Ergon.*, vol. 118, p. 104264, Apr. 2024, doi: <https://doi.org/10.1016/j.apergo.2024.104264>
- [8] V. Tripathi and A. Bhadauria, “Leveraging the competency of condition monitoring system for achieving excellence in operations management,” *Discov. Sustain.*, vol. 6, p. 452, May 2025, doi: <https://doi.org/10.1007/s43621-025-01285-8>
- [9] A. Feldbusch, H. Sadegh-Azar, and P. Agne, “Vibration analysis using mobile devices (smartphones or tablets),” *Procedia Eng.*, vol. 199, pp. 2790–2795, 2017, doi: <https://doi.org/10.1016/j.proeng.2017.09.543>

- [10] T. B. Brown *et al.*, “Language models are few-shot learners,” 2020, *arXiv:2005.14165*.
- [11] A. Smeyatsky, “A comprehensive guide to vibe coding and context engineering: Unlocking AI superpowers by August 2025,” LinkedIn Pulse, Accessed: Aug. 14, 2025. [Online]. Available: <https://www.linkedin.com/pulse/comprehensive-guide-vibe-coding-context-engineering-ai-smeyatsky-emptnf>
- [12] S. R. Cavalcante, E. R. Ribeiro, and A. C. Oran, “The impact of AI tools on software development: A case study with GitHub Copilot and other AI assistants,” in *Proc. 27th Int. Conf. Enterp. Inf. Syst. (ICEIS)*, Porto, Portugal, Apr. 2025, pp. 245–252, doi: <https://doi.org/10.5220/0013294700003929>
- [13] J. Kreutzbender, “My thoughts and experiences with vibe coding (mid 2025),” Jeremy Kreutzbender, May 2025. [Online]. Available: <https://jeremykreutzbender.com/blog/thoughts-and-experiences-vibe-coding-mid-2025>
- [14] J. H. Moore and N. Tatonetti, “Vibe coding: A new paradigm for biomedical software development,” *BioData Min.*, vol. 18, no. 1, Art. no. 46, Jul. 2025, doi: <https://doi.org/10.1186/s13040-025-00462-9>
- [15] M. Benedetti, “Vibe coding as a coding veteran. From 8-bit assembly to English-as-code,” Level Up Coding, Aug. 2025. [Online]. Available: <https://levelup.gitconnected.com/vibe-coding-as-a-coding-veteran-cd370fe2be50>
- [16] A. Shukla, J. K. Vijay, U. Sen, and J. Jain, “From prototyping to production: LLM chains carrying the software development pipeline,” *Int. J. Emerging Technol. Appl.*, vol. 11, no. 3, pp. 193–200, Jun. 2024. [Online]. Available: <https://www.ijetajournal.org/volume-11/issue-3/IJETA-V11I3P36.pdf>
- [17] M. Gupta, “Don’t be a vibe coder. Problems with vibe coding,” Medium, Mar, 2025. [Online]. Available: <https://medium.com/datascience-in-your-pocket/dont-be-a-vibe-coder-30fa7c525971>
- [18] DigitalOcean, “10 best vibe coding tools: LLM-powered code generators to try,” DigitalOcean, 2025. [Online]. Available: <https://www.digitalocean.com/resources/articles/vibe-coding-tools>
- [19] xAI, “Grok,” xAI, 2025. [Online]. Available: <https://grok.x.ai>
- [20] D. Davies, “Code generation and debugging with the Grok 4 API,” Weights & Biases, Jul. 2024, Accessed: Aug. 30, 2025. [Online]. Available: <https://wandb.ai/onlineinference/genai-research/reports/Code-generation-and-debugging-with-the-Grok-4-API--VmldzoxMzUzOTUwOA>
- [21] A. de SaintExupéry, *The Little Prince*, 1st ed. New York, NY, USA: Reynal & Hitchcock, 1943.
- [22] R. Sethi, *Software Engineering: Basic Principles and Best Practices*, 1st ed. Cambridge, UK: Cambridge University Press, 2023.
- [23] S. K. Pal, “What is spiral model in software engineering?,” GeeksforGeeks, Jul. 2025. [Online]. Available: <https://www.geeksforgeeks.org/software-engineering/software-engineering-spiral-model/>
- [24] S. R. Schach, *Classical and ObjectOriented Software Engineering with UML and Java*, 4th ed. Boston, MA, USA: WCB/McGrawHill, 1999.
- [25] K. Beck and M. Fowler, *Planning Extreme Programming*, 1st ed. Boston, MA, USA: Addison-Wesley Professional, 2000.
- [26] Pallets Projects, “Welcome to Flask – Flask Documentation (3.1.x),” Flask, Accessed: 2025. [Online]. Available: <https://flask.palletsprojects.com/>
- [27] Google, “Google scholar,” accessed: 2020-10-20. [Online]. Available: <http://scholar.google.com/>
- [28] T. J. McCabe, “A complexity measure,” *IEEE Trans. Software Eng.*, vol. 2, no. 4, pp. 308–320, Dec. 1976, doi: <https://doi.org/10.1109/TSE.1976.233837>
- [29] United States Congress. 91st Congress, 2nd Session. (1970, Dec. 29). *Pub. L. 91596, OSH Act of 1970*. [Online]. Available: <https://www.osha.gov/laws-regs/oshact/completeoshact/>
- [30] European Union. (2016, Apr. 27). *Regulation (EU) 2016/679 of the European Parliament and of the Council, General Data Protection Regulation (GDPR)*. [Online]. Available: <https://eur-lex.europa.eu/eli/reg/2016/679/oj>
- [31] United States Congress. 104th Congress, 2nd Session. (1996, Aug. 21). *Pub. L. 104191, Health Insurance Portability and Accountability Act of 1996*. [Online]. Available: <https://www.govinfo.gov/link/plaw/104/public/191>

BIOGRAPHICAL NOTES

MICHAEL DORIN

Michael Dorin holds a PhD in Computer Science from Universität Würzburg, Germany, with a specialization in software readability and quality. He is currently an Assistant Professor in Software Engineering and Data Science at the University of St. Thomas and previously served as a professor at Metropolitan State University in St. Paul, Minnesota. He has more than three decades of professional experience in software development across diverse engineering environments, with a focus on public safety communications and medical devices, including pacemakers, telephony systems,





and aircraft navigation technologies. Earlier in his career, he contributed to the initial deployment of worldwide email and document exchange systems at IBM. In addition to his academic career, he founded and managed EDI Enterprises, a telecommunications products company. His recent publications include work on genetic algorithms for e-waste mitigation (2025), machine learning applications for endangered language restoration (2025), ethical considerations in software engineering (2021), and linguistic economy in programming identifiers (2021). His research and professional interests focus on software readability and quality, natural language processing applications in software engineering, AI-assisted programming education, and endangered language preservation and documentation.

JUAN MANUEL MACHUCA

Juan Manuel Machuca holds a Master of Science degree in Teaching and Management from Universidad Marcelino Champagnat and a degree in Industrial Engineering from Universidad de Lima, Peru. He is currently a Professor and

Researcher at Universidad de Lima and Universidad del Pacífico, where he is a member of the Industry 4.0 and Applied Analytics Research Group. Throughout his career, he has carried out extensive consulting activities in logistics, planning, and commercial information systems. His recent publications include work on goal programming for vehicle routing in megacity beverage distribution (2025), lean management practices in retail (2023), virtual learning satisfaction in engineering education (2021), and humanitarian logistics optimization under uncertainty (2019). His research has demonstrated practical impact in solving complex real-world problems, particularly in Peru's urban contexts. His areas of expertise include operations research, humanitarian logistics, vehicle routing optimization, disaster management, lean management practices, and emerging technologies, including digital twins and machine learning applications in warehouse management. His work contributes to sustainable development goals, particularly the creation of sustainable cities and communities through improved logistics and supply chain management systems.

Improving a Bakery's Service Level Using Machine Learning, Process Standardization, and Packaging Redesign

Sergio Mercado Fernández Concha¹ , Santiago A. Vasquez Montero² , Ezilda M. Cabrera Gil Grados³ ,
Rafael Chávez-Ugaz⁴ 

¹20211706@aloe.ulima.edu.pe, ²20202197@aloe.ulima.edu.pe, ³ecabrera@ulima.edu.pe, ⁴rchavez@ulima.edu.pe

¹²³⁴Carrera de Ingeniería Industrial, Universidad de Lima, Perú

Received: August 15, 2025 / Accepted: October 15, 2025 / Published: 5 June, 2026

doi: <https://doi.org/10.26439/cii2025.8655>

ABSTRACT—This paper proposes a model to improve the service level of a pastry shop that faced issues such as incomplete deliveries, product damage, and delivery delays. The proposed solution integrates three components: (i) a machine learning (ML) model for delivery route optimization, (ii) standardization of the order dispatch process through manuals and checklists, and (iii) a packaging redesign incorporating internal supports and waterproof liners. As a result, the fill rate (FR) increased from 89.81% to 94.28%, the damaged delivery rate (DDR) decreased from 5.58% to 3.61%, and late deliveries were reduced from 5.07% to 1.26%. In addition, the proposed model avoided the emission of 574 kg of CO₂ per year. This model is applicable to small and medium-sized enterprises (SMEs) seeking to improve their logistics, reduce operating costs, and increase customer satisfaction through more efficient and sustainable processes.

Index Terms—Confectionery, machine learning, packaging, service level, standardized processes.

I. INTRODUCTION

The pastry sector has experienced sustained growth at the regional level, driven by an increasingly demanding consumer who values not only the quality of the product, but also its presentation, sustainability and punctuality in delivery [1], [2]. In Latin America, annual growth of 5.8% is projected for the premium segment, associated with increased purchasing power and a growing preference for tailored experiences [3]. This environment has placed increasing pressure on companies' operational capacity, requiring greater logistical efficiency, assurance of product integrity during transport, and minimization of order-picking errors [4], [5]. Likewise, the need to adopt responsible practices has prompted a re-evaluation of packaging

material usage, optimization of resource consumption, and reinforcement of process traceability. The accelerated digitalization of the sales channel has exposed the limitations of traditional distribution schemes, making it essential to incorporate technological solutions that allow predictive planning and the maintenance of consistent service levels in highly competitive contexts [6].

However, many bakeries continue to face structural deficiencies in their logistics operations. The case analyzed exhibits a service level of 89.81%, below the recommended standard of 95%, along with a damaged delivery rate (DDR) of 5.58%, a preparation error rate (PER) of 4.61%, and a delivery inaccuracy (DI) of 5.07%. Unlike previous studies that address isolated solutions, this work integrates technological, operational and structural components to jointly address logistical failures, which represents an original contribution to the artisanal bakery sector.

In response to this problem, a comprehensive solution based on three main components is proposed: an intelligent dispatch system using machine learning (ML), process standardization through visual tools, and the redesign of technical packaging. Previous studies have addressed similar problems in bakery supply chains, primarily focusing on waste reduction or delivery time improvements through specific technological approaches [3], [15]. However, unlike these works, this study addresses a comprehensive operational challenge by integrating logistical precision, real-time traceability, and packaging structural redesign under sustainability criteria. This convergence of logistical, human, and environmental dimensions increases the complexity of the problem and requires multidisciplinary solutions that extend beyond the isolated approaches proposed in the literature [7], [8]. This combination seeks to improve logistical accuracy, reduce transit times, and ensure product integrity. Similar studies have shown that these strategies can reduce waste in bakery supply chains

by up to 30% [3], [4], while also increasing customer satisfaction through reduced service variability [5].

The artificial intelligence component was developed using a multiple regression model based on historical data and real-time traffic information, following approaches aimed at route optimization and emission reduction [6], [9]. In parallel, operational standardization—based on visual control mechanisms and role definition—reduces human errors, improves traceability and increases employee performance [10], [11]. Finally, the packaging redesign considered the NTP 209.027:2012 and ISO 18601:2013 standards, prioritizing stackability, structural strength and sustainability, in accordance with guidelines related to the use of active packaging in bakery products [12].

The results were validated through pilot tests and simulations, showing an increase in the fill rate (FR) to 94.28%, a reduction in the DDR to 3.61%, and a decrease in the DI to 1.26%. In addition, the avoidance of 574 kg of CO₂ per year was achieved through waste reduction, demonstrating that the proposed approach is not only operationally viable, but also environmentally sustainable.

II. LITERATURE REVIEW

A. Outbound Logistics

Outbound logistics represents one of the greatest challenges in the food industry, particularly for companies handling perishable products such as pastries. Issues such as poor route planning, delivery delays, and inefficient dispatching increase operational costs negatively affect customer satisfaction. Studies indicate that these issues directly affect service quality, highlighting the need for smarter logistics systems [13]. In this context, Bei *et al.* [14] developed an intermodal transport model for perishable goods that reduces both costs and product deterioration, improving delivery efficiency by up to 18% for temperature-sensitive items.

B. Implementation of Advanced Technologies

The use of technologies such as ML has become essential to make food supply chains more efficient and reliable. These tools assist in predicting delivery times, managing unexpected changes, preventing logistical issues, and optimizing resource utilization [15], [16]. Recent research has also demonstrated how technology can support more sustainable operations. For example, Nannar *et al.* [17] created a model that combines efficiency measurement with sustainability goals, improving logistics performance and resource use by up to 20% in perishable food systems. Likewise, Nikseresht *et al.* [18] reviewed over 150 studies and found that ML models combining prediction and optimization can reduce emissions and process variability by up to 25%, demonstrating their strong potential to link efficiency with sustainability.

C. Quality of Service

The quality of service in the food sector is a key factor for competitiveness. It is determined not only by the quality of the final product but also by the accuracy of order preparation, delivery punctuality, and the condition in which products reach the customer. Standardization of operational processes is a fundamental strategy that reduces variability, minimizes errors and ensures consistent service levels, positively impacting customer perception and loyalty [19].

D. Food Waste

Food waste represents a critical problem in the bakery and pastry industry. A significant portion of these losses results from product damage during handling and transport, primarily due to inadequate packaging or suboptimal handling processes. Research emphasizes the importance of implementing strategies such as packaging redesign to provide greater protection during distribution, as well as improving logistics practices to mitigate both economic and environmental losses [20].

E. Sustainability

Sustainability plays a key role across all company activities, influencing both operations and their environmental and social impact. Optimizing routes, reducing product damage, and improving packaging not only save costs but also reduce CO₂ emissions, lower material usage, and minimize waste—supporting business models aligned with the Sustainable Development Goals (SDGs) [21]. Likewise, Prayitno and Wicaksono [22] introduced a framework that uses artificial intelligence to enhance collaboration among logistics partners in cities, showing that AI-based coordination can reduce CO₂ emissions by nearly 30%, while improving transparency and flexibility in shared logistics systems.

III. METHODOLOGY

This study applied a continuous improvement methodology, combining industrial engineering techniques, data science and product redesign, with the aim of increasing the service level in a pastry shop. The proposal was structured around three main axes as shown in Fig. 1:

Logistics optimization using ML for delivery time prediction and route sequencing.

- Standardization of operational processes in order preparation and dispatch activities.
- Redesign of packaging, aimed at reducing damage to the product and improving logistics efficiency.

Each axis included the analysis of operational data, the technical design of the solution and its implementation under an engineering approach tailored for SMEs.

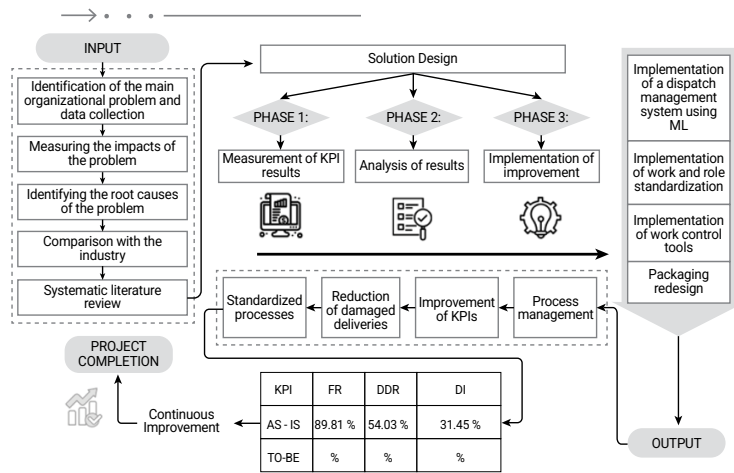

Fig. 1. Macro model of the solution proposal.

A. Logistics Optimization Through ML

The ML model was developed with the aim of reducing delivery times and improving accuracy in logistics planning. The CRISP-DM (Cross Industry Standard Process for Data Mining) methodological model was followed, structured into six phases: business understanding, data understanding, data preparation, modeling, evaluation and implementation.

- 1) *Data Collection and Analysis*: Historical operational data from the company's management system were used, considering the following variables:
 - Destination store
 - Departure date and time
 - Charging time
 - Download time
 - Transit time
 - Day of the week
 - Traffic condition

- 2) *Predictive Model*: A supervised regression model using Random Forest was applied to predict transit times based on multiple factors. The model was trained on a structured dataset containing 1,153 records.
- 3) *Representation of the Predictive Function*: Although the Random Forest model does not generate an explicit equation, conceptually the prediction follows the function:

$$T_{transit} = f(\text{Destination}, H, \text{Day}_{week}, T, \text{Load})$$

Where:

- f = Function generated by decision trees
- *Destination* = Destination store

- H = Departure times
- Day = day of the week
- T = Traffic
- Load = Operational load

- 4) *Optimal Route Sequencing*: Transit time prediction was integrated into a comprehensive search algorithm that calculates all possible permutations of stores to visit. The optimal sequence corresponds to the one that minimizes the total travel time subject to the constraint of point-to-point routes (departure from and return to the plant):

$$\min \sum_{i=1}^n T_{traffic_i}$$

B. Standardization of Operational Processes

The second axis of improvement consisted of the standardization of critical processes related to order preparation and dispatch.

- 1) *Analysis of the Current Process (AS-IS)*: A detailed mapping of the AS-IS process was carried out, identifying tasks with high operational variability and risk of errors, mainly in:
 - Armed with requests
 - Product verification
 - Vehicle charging
- 2) *TO-BE Process Design*: Standard operating procedures were defined for the following activities:
 - Standard order assembly sequence
 - Quality control and dispatch checklist
 - Standardization of in-vehicle load criteria

Visual tools were implemented and tasks were redistributed to ensure operational traceability.

- 3) *Ergonomics and Operational Safety*: Criteria were applied according to NTP 399.010:2004 and ISO 11228, prioritizing the reduction of physical efforts in handling and loading tasks.

C. Packaging Redesign

The packaging redesign focused on reducing the DDR and improving transportation efficiency.

- 1) *Diagnosis of Damage*: The following were identified as the main causes of product damage:
 - Internal movement of products during transport
 - Strong vibrations on the road
 - Insufficient material impermeability
- 2) *Technical Packaging Design*: The new packaging was designed according to three fundamental criteria:
 - *Structural protection*: Lateral reinforcements and internal dividers.
 - *Waterproofing*: Incorporation of laminates resistant to moisture and grease.

The new packaging structure includes internal reinforcements and a waterproof layer that protects the product from movement and moisture during transport. The unfolded layout (bottom left) illustrates how the structure was adapted to enhance stability and facilitate stacking.

D. Calculation of Operational Indicators

The following indicators were defined to quantify operational performance:

- Fill rate (FR)

$$FR = \frac{\text{Complete and on time products}}{\text{Total ordered products}} \times 100$$

- Damaged delivery rate (DDR)

$$DDR = \frac{\text{Damaged products}}{\text{Total ordered products}} \times 100$$

- Preparation error rate (PER)

$$PER = \frac{\text{Errors}}{\text{Total ordered products}}$$

- Delivery inaccuracy (DI)

$$DI = \frac{\text{Extra working minutes}}{\text{Schedule working minutes}}$$

E. Environmental Assessment

Environmental evolution was carried out considering three main factors: emission reduction, waste minimization, and material savings.

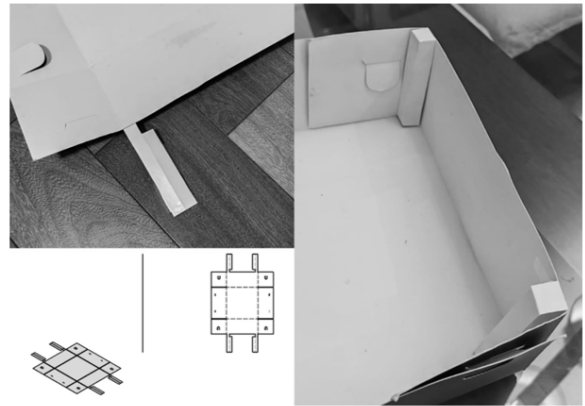

Fig. 2. Redesigned packaging model.

- 1) *Reduced Emissions Calculation*: The CO₂ emissions avoided by the reduction in vehicle operating hours were estimated.

$$\text{Emissions}_{CO_2ed} = (H_{before} - H_{after}) * \text{FUELConsumption}_{vehicle} \times \text{Factor}_{CO_2}$$

Where:

- H_{before} = Total delivery hours before upgrade
- H_{after} = Total hours of delivery after upgrade
- $\text{Consumption}_{vehicle}$ = Liters of fuel per hour
- Factor_{CO_2} = Kg CO₂ emitted per liter of fuel

- 2) *Reduction of Waste Generated*: The reduction of damaged units was calculated

$$\text{Waste}_{reduced} = \text{Units}_{damaged\ before} - \text{Units}_{damaged\ after}$$

- 3) *Savings in Packaging Materials*: Material savings resulting from the more efficient packaging redesign were estimated:

$$\text{Material}_{savings} = (M_{before} - M_{after}) \times \text{added units}$$

Where:

M_{before} and M_{after} represent the weight of packaging material per unit before and after.

IV. RESULTS AND VALIDATION

The validation of the proposal was carried out as shown in Fig. 3, through pilot tests in real operations over four weeks, as well as simulations using historical data. The results demonstrate significant improvements in the primary service level indicators.

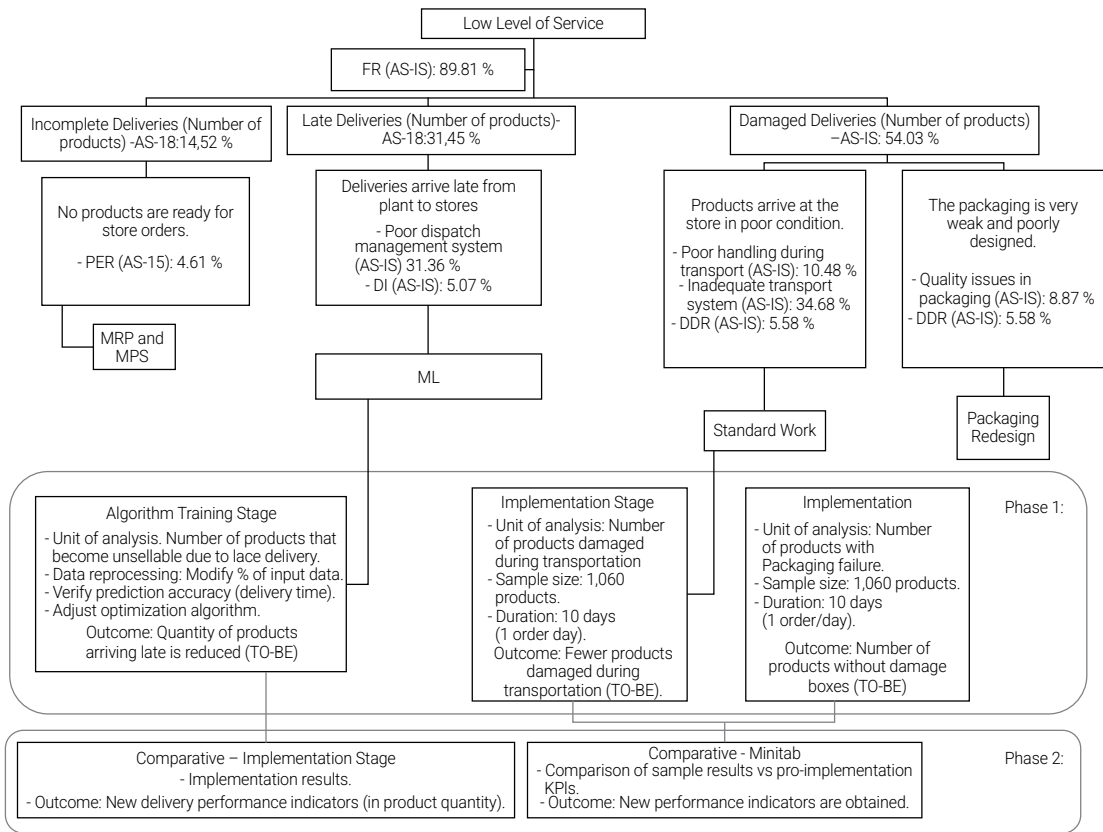

Fig. 3. Macro-level validation model diagram.

A. Results

The results listed in Table I were obtained through a 10-day implementation in the company's real operations, complemented by simulations using historical data from the management system. Operational indicators, including FR, DDR, PER, and DI, were measured before and after implementing the proposed improvements. Each value corresponds to the average observed during the test period, verified through field records and daily monitoring reports.

The improvement in the FR and the significant reduction in the DI reflect the positive impact of the ML model applied to logistics optimization. On the other hand, the reduction of DDR and PER demonstrates the effectiveness of process standardization and packaging redesign.

B. Validation of the ML Model

The Random Forest-based predictive model achieved a coefficient of determination (R^2) of 0.91 and a root mean square error (RMSE) of 3.74 minutes, demonstrating high accuracy in predicting transit times by considering variables such as traffic, departure time, day of the week, and operational load.

The application of the model, combined with the exhaustive route-sequencing algorithm, reduced total

TABLE I
RESULTS BEFORE AND AFTER IMPROVEMENT

Indicator	Results		
	Initial situation	Improved situation	Change (%)
FR	89.81%	94.28%	+4.98%
DDR	5.58%	3.61%	-35.3%
PER	4.61%	2.11%	-54.23%
DI	5.07%	1.26%	-75.14%

daily travel time by 17.8% and decreased variability in delivery times.

C. Process Standardization Validation

The validation of the standardization was carried out through an operational pilot test, with the following results:

- PER was reduced by 54.23%.
- Assembly and dispatch times improved by 12%.

- Recurring errors in the verification, loading, and assembly processes were eliminated through the implementation of checklists, visual controls, and task redistribution.

D. Packaging Redesign Validation

The packaging redesign was validated through the same pilot test, focusing on transport resistance and the ability to protect the product. The results were as follows:

- Reduced the DDR from 5.58% to 3.61%, equivalent to a 35.30% improvement.
- Elimination of damage caused by vibration, shock, or internal displacement.

V. DISCUSSION

The results indicate that the improvement proposal significantly reduced the main operational failures affecting the bakery’s service level. The combined implementation of three initiatives—logistics optimization via ML, standardization of operational processes, and packaging redesign—enabled a comprehensive approach to addressing DIs, product damage, and partial order fulfillment.

The increase in the FR, from 89.81% to 94.28%, confirms that the comprehensive solution significantly improved the company’s ability to fulfill orders in quantity and timeliness, approaching the 95% standard recommended for efficient logistics operations in the sector [18].

The DI, reduced from 5.07% to 1.26%, demonstrates the effectiveness of logistics optimization via the ML model. This result surpasses the 22% waste reduction reported by Aljohani [13], who applied route optimization techniques without integrating real-time traffic or validating with actual data. Instead, our approach used supervised prediction with Random Forest, incorporating real-time traffic, which resulted in a 17.8% reduction in total daily travel time.

The PER decreased from 4.61% to 2.11%, representing a 54.23% improvement. This result aligns with the findings of Quiroz-Flores et al. [14], who reported a 13% service level improvement through task standardization, although their approach did not include an ergonomic task redistribution phase as proposed in this study. The combination of checklist, visual control and task distribution improved assembly times and eliminated recurring errors, reinforcing the findings of Burgess et al. [19] on the importance of traceability in food supply chains.

The DDR decreased from 5.58% to 3.61%, representing a 35.30% improvement. This result confirms the effectiveness of the new packaging design and aligns with the recommendations of Qian et al. [12], who emphasize that packaging with active elements can prevent damage from moisture and vibrations. Unlike Qian, our redesign incorporated

Analytical Flowchart		PRODUCTS			
Diagram number: 2 Page: 1af 1		SUMMARY			
Object: Dispatch of bakery products	ACTIVITY	CURRENT	PROPOSED	ECONOMY	
Activity: Complete dispatch process	Operations	09	12	-	
	Transports	03	03	-	
	Delays	01	01	-	
	Inspections	02	02	-	
Method: PROPOSED	Storage	01	01	-	
Place: Plant, "La Crocante" Store	Distance (meters)	28	26	-	
Form number: 2	Time (minutes)	40	38	-	
Prepared by: Sergio Mercado, Santiago Vásquez					
Date: 09302025					
DESCRIPTION	C	D(m)	T (min)	SYMBOL	OBSERVATIONS
1. Make requirement			2	<input checked="" type="checkbox"/>	Store administrator
2. Send requirement to production			1	<input checked="" type="checkbox"/>	
3. Plan production			5	<input checked="" type="checkbox"/>	Production manager
4. Produce products				<input checked="" type="checkbox"/>	
5. Generate route with ML model			3	<input checked="" type="checkbox"/>	Warehouse chief
6. Prepare transfer guide			3	<input checked="" type="checkbox"/>	
7. Load cart with products			2	<input checked="" type="checkbox"/>	Operator
8. Verty products with guide			2	<input checked="" type="checkbox"/>	
9. Wait for missing products			5	<input checked="" type="checkbox"/>	
10. Inform operator			1	<input checked="" type="checkbox"/>	Dispatcher
11. Prepare checklist					
12. Verify with checklist			2	<input checked="" type="checkbox"/>	
13. Take products to elevator			2	<input checked="" type="checkbox"/>	Operator
14. Load van			2	<input checked="" type="checkbox"/>	Dispatcher
15. Drive to store				<input checked="" type="checkbox"/>	Driver
16. Receive products			2	<input checked="" type="checkbox"/>	
17. Record condition			2	<input checked="" type="checkbox"/>	Store administrator
18. Separate products			1	<input checked="" type="checkbox"/>	
19. Store products			1	<input checked="" type="checkbox"/>	End of flow
Total			38	02 03 01 12 01	

Fig. 4. Process analysis diagram (PAD).

internal support elements and waterproof sheets within the same current material, achieving an improvement without the use of external or specialized materials.

At a comprehensive level, the study proposes a multidisciplinary solution impacting five key dimensions: logistics precision, operational ergonomics, environmental sustainability, organizational standardization, and customer experience. Unlike studies such as Lahane et al. [11], which address barriers to technological adoption theoretically, this proposal demonstrates how these barriers can be overcome in a real SME through gradual implementation, internal training, and monitoring using accessible tools such as Minitab and Python.

Finally, validation through pilot testing confirmed that the improvements are viable and sustainable under real operating conditions. This positions the proposal as a replicable model for SMEs in the food sector facing similar problems.

VI. CONCLUSIONS

The implemented proposal managed to significantly improve the service level of the pastry shop through three key actions: ML, standardization of processes and redesign of the packaging.

The ML model reduced the DI from 5.07% to 1.26%, improving logistics accuracy. Process standardization decreased the PER from 4.61% to 2.11%, while packaging redesign reduced the DDR from 5.58% to 3.61%. As a result, the FR increased from 89.81% to 94.28%.

In conclusion, the integration of these tools is effective and replicable in SMEs facing similar challenges, provided it is accompanied by training and continuous operational monitoring.

REFERENCES

- [1] S. M. Chaerudin and A. Syafarudin, "The effect of product quality, service quality, price on product purchasing decisions on consumer satisfaction," *Ilomata Int. J. Tax Account.*, vol. 2, no. 1, pp. 61–70, Jan. 2021, doi: 10.52728/ijtc.v2i1.202.
- [2] A. E. Rivas, G. G. Rivas, J. M. A. Iran, and J. A. R. Balagno, "There's a whisk, there's a way: The customer satisfaction on the bakery business in Lantapan," *Int. J. Sci. Manag. Res.*, vol. 6, no. 12, pp. 108–126, Jan. 2023, doi: 10.37502/IJSMR.2023.61209.
- [3] Markets and Markets, "Latin America Premium Bakery Market - Forecast to 2032," Markets and Markets, 2023.
- [4] S. Hadi, Y. R. Satato, and M. N. Wawo, "Service quality strategy in increasing customer satisfaction at Ice Bakery Tanjung Redeb Berau Regency," in *Proc. Int. Conf. Digital Adv. Tourism, Manage. Technol. (ICTMT)*, vol. 1, no. 2, pp. 674–678, Dec. 2023, doi: 10.56910/ictmt.v1i2.146.
- [5] E. Goryńska-Goldmann, M. Gazdecki, K. Rejman, S. Łaba, J. Kobus-Cisowska, and K. Szczepański, "Magnitude, causes and scope for reducing food losses in the baking and confectionery industry—A multi-method approach," *Agriculture*, vol. 11, no. 10, p. 936, Sep. 2021, doi: 10.3390/agriculture11100936.
- [6] IAB Peru, "E-commerce Study 2023–2024," IAB Peru, 2024.
- [7] R. Manzini and R. Accorsi, "The new conceptual framework for food supply chain assessment," *J. Food Eng.*, vol. 115, no. 2, pp. 251–263, Mar. 2013, doi: 10.1016/j.jfoodeng.2012.10.026.
- [8] D. Ivanov, "Viable supply chain model: Integrating agility, resilience and sustainability perspectives—Lessons from and thinking beyond the COVID-19 pandemic," *Ann. Oper. Res.*, vol. 319, no. 1, pp. 1411–1431, Dec. 2022, doi: 10.1007/s10479-020-03640-6.
- [9] M. Rodrigues, V. Miguéis, S. Freitas, and T. Machado, "Machine learning models for short-term demand forecasting in food catering services: A solution to reduce food waste," *J. Clean. Prod.*, vol. 435, Jan. 2024, doi: 10.1016/j.jclepro.2023.140265.
- [10] G. P. Pacheco-Moreira and Y. Ramos-Alfonso, "Evaluación de la calidad del servicio y la satisfacción del cliente interno en una cooperativa de ahorro y crédito [Evaluation of service quality and internal customer satisfaction in a savings and credit cooperative]," *Polo del Conocimiento*, vol. 5, no. 7, pp. 722–735, Jul. 2020.
- [11] S. Lahane, V. Paliwal, and R. Kant, "Evaluation and ranking of solutions to overcome the barriers of Industry 4.0 enabled sustainable food supply chain adoption," *Cleaner Logist. Supply Chain*, vol. 8, Sep. 2023, doi: 10.1016/j.clscn.2023.100116.
- [12] M. Qian et al., "A review of active packaging in bakery products: Applications and future trends," *Trends Food Sci. Technol.*, vol. 114, pp. 459–471, Aug. 2021, doi: 10.1016/j.tifs.2021.06.009.
- [13] K. Aljohani, "Optimizing the distribution network of a bakery facility: A reduced travelled distance and food-waste minimization perspective," *Sustainability*, vol. 15, no. 4, Feb. 2023, doi: 10.3390/su15043654.
- [14] H. Bei, M. Yu, T. Yang, and R. Murcio, "Optimization of intermodal transportation routes for perishable goods considering customer satisfaction," *Res. Transp. Bus. Manag.*, vol. 59, Mar. 2025, doi: 10.1016/j.rtbm.2024.101261.
- [15] A. L. V. Rodrigues, G. Gomes, and M. Bouzon, "Lean logistics 4.0: Concepts and key performance indicators," *Braz. J. Dev.*, vol. 9, no. 7, pp. 22172–22197, Jul. 2023, doi: 10.34117/bjdv9n7-071.
- [16] M. L. Deng and P. Feng, "A food traceability system based on blockchain and radio frequency identification technologies," *Journal of Computer and Communications*, vol. 8, no. 9, pp. 17–27, 2020, doi: 10.4236/jcc.2020.89002
- [17] S. Nannar, S. Sindhuchao, C. Chaiyaphan, and K. Ransikarbum, "Optimization of the sustainable food supply chain with integrative data envelopment analysis approach," *Int. J. Manag. Sci. Eng. Manag.*, vol. 19, no. 4, pp. 278–293, Feb. 2024, doi: 10.1080/17509653.2024.2317479.
- [18] A. Nikseresht, S. Shokouhyar, E. B. Tirkolaei, S. Shokoohyar, N. Pishva, and V. Simic, "Machine learning and data-driven models in sustainable supply chain management: A systematic literature review with content analysis," *Int. J. Logist. Res. Appl.*, pp. 1–40, Jun. 2025, doi: 10.1080/13675567.2025.2517639.
- [19] P. R. Burgess, F. T. Sunmola, and S. Wertheim-Heck, "A review of supply chain quality management practices in sustainable food networks," *Heliyon*, vol. 9, no. 11, Nov. 2023, doi: 10.1016/j.heliyon.2023.e21179.

- [20] A. Bhardwaj, R. Soni, L. P. Singh, and R. S. Mor, "A simulation approach for waste reduction in the bread supply chain," *Logistics*, vol. 7, no. 1, p. 2, Jan. 2023, doi: 10.3390/logistics7010002.
- [21] J. A. Valencia Granados, "Importance of measuring the level of service or fill rate in modern logistics," *Realidad Empresarial*, vol. 10, pp. 75-78, Dec. 2020, doi: 10.5377/reuca.v0i10.10579.
- [22] K. A. Prayitno and H. Wicaksono, "Optimizing the sustainability of collaborative logistics in urban area through ontologies and causal artificial intelligence: A conceptual framework," *Procedia CIRP*, vol. 130, no. 10, pp. 1070-1076, Jan. 2024, doi: 10.1016/j.procir.2024.10.208.

BIOGRAPHICAL NOTES

SERGIO MERCADO FERNÁNDEZ CONCHA

Sergio Mercado Fernández Concha holds a Bachelor's degree in Industrial Engineering from Universidad de Lima, Peru. He currently works as a Large Enterprise Analyst at Interbank in Lima, Peru. He has developed academic projects aimed at improving processes, logistics, and service levels in food and retail companies, implementing machine learning tools, process standardization, and packaging redesign. His areas of interest include corporate finance, process improvement, and operations management.

SANTIAGO ALBERTO VASQUEZ MONTERO

Santiago Alberto Vasquez Montero holds a Bachelor's degree in Industrial Engineering from Universidad de Lima, Peru. He currently works as an FX & Derivatives Sales Analyst in Capital Markets at Interbank in Lima, Peru, where he participates in the management and advisory of financial products linked to foreign exchange and derivatives in the institutional market. He has developed a thesis aimed at improving service levels in a pastry shop through machine learning tools, operational process standardization, and packaging redesign, with the goal of increasing operational efficiency and reducing distribution losses. His areas of interest include operational efficiency and process improvement.





EZILDA CABRERA GIL GRADOS

Ezilda Cabrera Gil Grados holds a Master's degree in Business Administration from Universidad ESAN, Peru, and a degree in Industrial Engineering from Universidad de Lima, Peru. She currently works as a professor in the Industrial Engineering Program at Universidad de Lima. She has published the book *Linear Programming Models: A Guide to Their Formulation and Solution* (Fondo Editorial de la Universidad de Lima, 2017) and several articles in academic conference proceedings, including "Improvement Proposal to Achieve Shrinkage Reduction in the Home Dispatch Process in a Retail Company," "The Origins and Evolution of Social Commerce: Enhancing E-Commerce Platforms with Social Features," "Home Office Physical and Psychosocial Ergonomic Effects on the Job Satisfaction of Service Sector Employees in Peru," and "Study of Carbon Monoxide Levels in the Most Traveled Streets of Metropolitan Lima," among others. Her main professional area of interest is operations research.

RAFAEL CHÁVEZ UGAZ

Rafael Chávez Ugaz holds a Master's degree in Strategic Business Administration from Centrum Católica, Peru; a Master of Business Administration in General and Strategic Management from Maastricht School of Management, the Netherlands; a degree in Management from the Netherlands; and a Bachelor of Engineering in Industrial Engineering from Universidad de Lima, Peru. He currently teaches in the Industrial Engineering Program at Universidad de Lima, where he is also a researcher and a member of the Faculty of Engineering Council. He previously participated as an associate researcher in technological innovation projects funded by Fondecyt. His publications include "Implementation of Lean Manufacturing and SLP in an SME in the Jewelry Sector: Case Study," published in the International Congress on Innovation and Trends in Engineering; "Ergonomic Risk Management Model Using RULA, NIOSH and OCRA Techniques in a Metalworking SME," published in the Proceedings of the LACCEI International Multi-Conference for Engineering, Education and Technology; and "Textile Characteristics of Huacaya Alpaca Fiber, According to Agroecological Zones, Sex and Age in the Puno Region (Peru)," published in the Peruvian Journal of Veterinary Research. His areas of interest include production operations for goods and services, supply chain management, and last-mile logistics.

Improving Production Plan Compliance through the Application of SMED and Standardized Work in a Soybean Oil and Shortening Company

Gonzalo A. Montoya-Marín¹ , Diego Mogollón-Sotomayor² , Jorge A. Corzo-Chavez³ ,
Gino Viacava-Campos⁴ 

¹20194346@aloe.ulima.edu.pe, ²20194334@aloe.ulima.edu.pe, ³jacorzo@ulima.edu.pe, ⁴geviacav@ulima.edu.pe

¹²³⁴Carrera de Ingeniería Industrial, Universidad de Lima, Perú

Received: August 15, 2025 / Accepted: September 13, 2025 / Published: 5 June, 2026

doi: <https://doi.org/10.26439/ciii2025.8656>

ABSTRACT—This study was conducted in a Peruvian company engaged in the production and commercialization of oils and shortenings. An initial assessment revealed that average production plan compliance was 81%, below the industry benchmark of 90–95%, adversely impacting operational efficiency and customer satisfaction. The objective was to evaluate whether the combined application of SMED (Single-Minute Exchange of Die) and Standardized Work could improve this metric. Field observations and document reviews informed the design of a pilot project involving targeted workflow modifications. Both the baseline and optimized scenarios were modeled using Arena simulation software and executed with 18 replications each. The optimized model achieved 88.4% compliance, reduced bottle transport time from 21.7 to 16.4 min (-24.4%), and shortened format change duration from 60.1 to 48.7 min (-19%). Shift production increased from 4,086 to 4,596 bottles (+12.5%). These improvements were driven by task reorganization, the use of a pallet jack, tool centralization, and a pre-operational checklist. The findings provide empirical evidence that integrating SMED with Standardized Work can deliver significant operational improvements in mass-consumption production environments, while reinforcing the applicability of Lean principles within the Peruvian industrial context. It is recommended to scale these interventions and conduct medium-term evaluations to ensure sustained impact.

Index Terms—Lean Manufacturing, operational efficiency, plan production compliance, SMED, Standardized Work.

I. INTRODUCTION

This article is organized as follows. Section I reviews related work; Section II describes the methodology and simulation

model; Section III presents the results; Section IV discusses the implications; and Section V concludes the paper. Despite numerous case studies on SMED and Standardized Work, a clear knowledge gap remains regarding their integrated effect on production plan compliance in edible-oil bottling lines within Latin American small and medium-sized enterprises (SMEs).

Accordingly, the research question guiding this study is as follows: To what extent does integrating SMED and Standardized Work improve production plan compliance and throughput in a Peruvian edible-oil bottling line?

The company selected for this research operates in the edible oils and fats sector. It began operations in January 1960 and, with over 64 years of presence in the Peruvian market, is primarily dedicated to the production and commercialization of soybean oil and shortening. Its main clients include prestigious restaurant chains recognized for their quality and service.

The company defines its mission as a commitment to producing and distributing high-quality products, supported by a team of professionals focused on meeting the needs of customers and consumers. In parallel, the company pursues a continuous improvement strategy by integrating new technologies and adhering to high-quality standards to maintain competitive and profitable production units, a common objective in the packaging sector aimed at enhancing operational performance [1]. In doing so, it actively contributes to the country's ongoing development, alongside other local manufacturing companies in Lima that have adopted improvement methodologies to reduce waste and enhance efficiency [2].

The company's vision is to become a nationally and internationally competitive player in the sector by diversifying and improving its product portfolio.

Currently, the company reports an average production plan compliance rate of 81%, which is considered low, and highlights an opportunity to boost productivity through the implementation of Lean Manufacturing methods [3]. This condition reflects a technical gap between the company and its industry peers. The shortfall impacts several stages of the production process, particularly preparation times, which could be optimized through corrective actions—an area where tools such as SMED have proven indispensable, especially for SMEs [4]. Accordingly, this study focuses on the oil packaging process across multiple formats. The scope includes both the material storage area (e.g., plastic bottles and jerrycans) and the production zone, where oil filling and packaging operations are performed. The analysis identified frequent stoppages of the filling machines on packaging Lines No. 1 and No. 2 as the primary cause of low production plan compliance. Fig. 1 illustrates a portion of the production area.

Faced with similar challenges, many production companies have adopted Lean Manufacturing tools to improve the efficiency of their assembly lines and better meet customer requirements [5].

SMED is one of the most effective Lean tools for reducing changeover time in bottling and packaging processes [6] and in improving overall productivity [7]. A study on European food manufacturers reported a 34% reduction in format changeover times following the application of SMED techniques [8]. Reinforcing this evidence, another study conducted in a major European food manufacturer focused on eliminating production losses specifically during changeover operations, demonstrating the targeted effectiveness of SMED [9]. These improvements were achieved by converting internal activities into external ones and by standardizing task sequences, in line with contemporary operations management approaches aimed at revitalizing and optimizing setup reduction activities [10].

Furthermore, one investigation reported a reduction in average control time from 16.2 to 13.9 s through the application of digital Standardized Work tools in a packaging line [11]. Standardized Work has also proven effective across diverse industries. Clear definition of standard procedures and adequate operator training are essential to avoid confusion and ensure consistent execution [12]. In the construction sector, the application of Standardized Work has been used to modularize processes and has resulted in significant improvements in coordination and output quality [13]. Establishing a Standard Work routine is a fundamental Lean practice for achieving consistent results in production environments [14].

This broad application highlights the versatility of SMED and Standardized Work in environments where frequent changeovers and equipment flexibility are essential for maintaining productivity and reducing downtime, while effective worker training and process consistency are critical to improving operational outcomes.



Fig. 1. Photograph of the production area of soybean oil.

This analysis confirms that SMED is applied in high-volume production environments, where changeover time has a significant impact on productivity [15]. In contrast, Standardized Work is more prevalent in labor-intensive settings where task consistency and training are critical.

Although, several studies have demonstrated the benefits of SMED and Standardized Work in European and Asian industries, a knowledge gap remains regarding their combined application in small and medium-sized food companies in Latin America. This research addresses that gap by evaluating whether the integration of both tools can improve production plan compliance in a Peruvian soybean oil and shortening company.

II. METHODOLOGY

The methodological design directly addresses the identified knowledge gap by combining a structured SMED intervention—focused on externalizing internal setup tasks and formalizing a pre-changeover checklist—with role-based Standardized Work that defines staffing levels, task sequences, and takt-aligned cycle times.

The joint effect was assessed through a two-scenario simulation (AS-IS vs. improved) using matched input distributions, 18 replications per scenario, and 95% confidence intervals, thereby isolating the incremental contribution of the integrated approach to production plan compliance and output.

The methodology focused on the proposal and design of improvements using Lean Manufacturing tools, particularly SMED and Standardized Work, without initially proceeding to full implementation. These tools were selected to address the key inefficiencies identified in the bottling line



Fig. 2. Proposed model diagram.

TABLE I
AS-IS ACTIVITIES IN THE PRODUCTION AREA

Activities	Time (min)	Internals	Externals
Adjusting the height level of packaging machine.	17.6	X	
Change of limits, according to their presentation.	19.8	X	
I move the bottles from the warehouse to bottling area.	21.7	X	
Transfer of component boxes, according to the presentation.	1.7	X	
Filling the hoppers with bottles, according to the presentation	8.9	X	
Activities	Time (min)	Internals	Externals
Bring the boxes from the warehouse to packing area.	4.2	X	
The components of the filling machine (nozzle, hose, etc.) were checked.	5.4	X	

process and to target unplanned downtime and operational variability.

In the case of SMED, the proposal focused on reducing the long changeover times between 500 mL and 1 L product formats. The actions included separating internal and external setup tasks, preparing a checklist to ensure the availability of tools and materials before initiating the changeover, and designating a specific operator responsible for tool and accessory preparation. Additionally, tasks that could be executed while the machine remained operational were identified to optimize setup time.

The proposed model diagram in Fig. 2 represents the flow of the improvement project, from data collection to the results obtained. In the Inputs stage, historical and current production records, activity times, downtime per line, and selling prices are collected. Subsequently, the company's situation is analyzed using tools such as the block diagram, cause-and-effect diagram, and Ishikawa diagram. Based on this diagnosis, Lean tools like SMED and Standardized Work are implemented.

Thereafter, the impact of these improvements is validated through simulations conducted in Arena software and a pilot test in the packaging area. Finally, as Outputs, improvements are observed in production plan compliance and in the identified KPIs, particularly with respect to time reduction. Table I lists all the internal activities that are in the AS-IS Scenario.

On the other hand, Table II lists all the activities that were modified for the TO-BE Scenario in the production area.

For the Standardized Work proposal, the focus was on addressing the lack of consistency in operator activities, especially during bottle feeding and replenishment tasks. A structured operating routine was proposed to enhance the timing and coordination between operators. Specific roles were assigned to ensure that one operator focused on feeding the hopper while the other handled bottle preparation. The proposal also recommended the implementation of a defined replenishment routine and documented procedures to support operator training.

In addition to these primary improvement tools, complementary initiatives were proposed to address minor yet impactful operational issues. For instance, the use of a visual indicator to monitor ink levels in the coding machine was suggested to prevent unexpected downtimes. Likewise, new instructions were created to ensure timely ink replacement, especially during operator breaks or periods of low activity.

All improvement proposals were developed based on time studies, direct field observations, and collaborative discussions with supervisors and operators. These proposals were subsequently evaluated through simulation and pilot validation, as detailed in subsequent sections of the paper. Fig. 3 can show the distribution obtained using the tool Input Analyzer.

Fig. 3 shows the resulting distribution, which follows a normal distribution selected based on a corresponding p value greater than 0.05. This result enabled the subsequent analysis:

TABLE II
TO-BE ACTIVITIES IN THE PRODUCTION AREA

Activities	Time (min)	Internals	Externals
Adjusting the height level of packaging machine.	15.1	X	
Change of limits, according to the presentation.	19.3	X	
I move the bottles from the warehouse to the bottling area.	16.4		X
Transfer of component boxes, according to the presentation.	1.3		X
Filling the hoppers with bottles, according to the presentation	8.9	X	
Bring the boxes from the warehouse to the packing area.	4		X
The components of the filling machine (nozzle, hose, etc.) were checked.	5.4	X	

- H_0 = Bag transfer times will follow a normal distribution.
- H_1 = Bag transfer times will not follow a normal distribution

Fig. 4 presents another of the obtained distributions, which follows a uniform distribution selected based on a corresponding p value greater than 0.05. This result enabled the subsequent analysis:

- H_0 = The bag hopper fill times will follow a uniform distribution.
- H_1 = The bag hopper fill times will not follow a uniform distribution.

Fig. 5 presents another example of the obtained distributions, which follows a uniform distribution selected based on a corresponding p value greater than 0.05. This result enabled the subsequent analysis:

- H_0 = The bag hopper fill times will follow a uniform distribution.
- H_1 = The bag hopper fill times will not follow a uniform distribution.

These figures contain examples of the distributions obtained from time measurements across the different processes within the company.

III. RESULTS

Implemented changes emphasized converting internal setup activities to external ones (e.g., tool pre-staging, line-side placement of format parts, and pre-changeover checks), consolidating tools and materials near the changeover point, and formalizing operator routines (including start-of-shift checks, bottleneck-focused assignments, and handoff standards).

Operationally, these changes reduced format change-over duration and inter-station travel time, stabilized cycle times at the filler and labeler, and increased effective

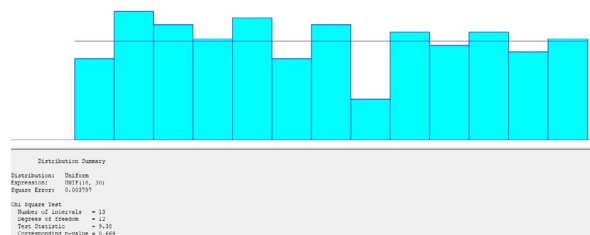

Fig. 3. Transferring the bags bottles by Input Analyzer.

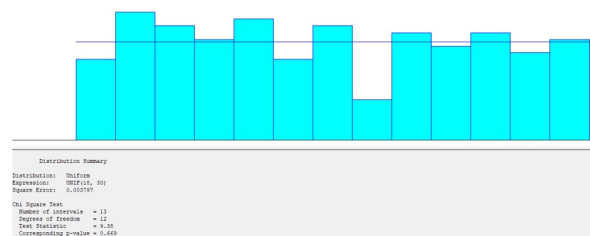

Fig. 4. Hopper filling time by Input Analyzer.

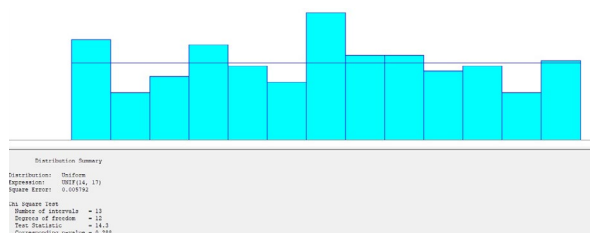

Fig. 5. Stacking of bottles by Input Analyzer.

machine availability during the first shift, translating into higher daily boxes produced and improved plan compliance.

In addition to the quantitative outcomes, it is important to highlight the practical modifications introduced during the pilot test. A checklist was created to ensure that ink refilling for the coding machine was prepared in advance, reducing



Fig. 8. Boxes produced by scenario.

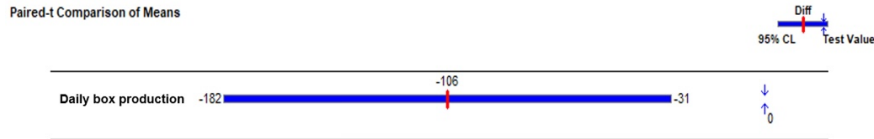

Fig. 9. Paired-t comparison of means.

This final part of the Arena model also differs from the original version. After the bottle filling process, once the current batch is completed and a new product presentation is initiated, the filling machine setup begins, specifically with the step-by-step replacement of the stoppers.

Similarly, after each oil bottle is capped, the capping machine setup begins, including height adjustment while the last bottles are being boxed and stacked.

As a result, the setup activities of the machines are converted from internal to external activities, allowing them to be performed while the machine and production line remain in operation. These changes can modify the number of boxes produced as shown in Fig. 8.

Additionally, a statistical comparison was carried out using Output Analyzer to evaluate the daily box production averages between the baseline and improved simulation models. The baseline model exhibited an average output of 681 boxes/day, with a 95% confidence interval of [646, 715], whereas the improved model increased this value to 766 boxes/day, with a corresponding interval of [737, 796]. As the confidence intervals do not overlap, the improvement is considered statistically significant. These results confirm that the proposed tools initiatives not only improved the production plan but also enhanced process consistency.

When confidence intervals overlap, a comparison of means is performed to assess the magnitude of the difference between them, as shown in Fig. 9.

A paired t-test was performed to confirm the statistical significance of the difference in daily production between the original and improved simulation models. The analysis yielded an average difference of -106 boxes per day, with a 95% confidence interval of [-182, -31]. As zero does not fall within this interval, the improvement is considered statistically significant, further validating the effectiveness of the proposed Lean initiatives.

The results confirmed that both the pilot test and the simulation supported the effectiveness of implementing SMED and Standardized Work. Quantitative outcomes, such as reduced changeover time and increased line availability, were complemented by qualitative improvements, including greater clarity in operator tasks and improved organization of work routines. All the results achieved by the simulation model are shown in Table III.

The Arena simulation provided a macro-level view of the improvements, demonstrating not only increased throughput but also reduced system congestion and downtime. The model validated the anticipated benefits and reinforced the value of the pilot observations by replicating them within a simulated environment.

IV. DISCUSSION

The findings demonstrate a strong synergy between practical implementation and simulation-based validation. The pilot test confirmed the immediate, real-world impact of the interventions, with a 20% reduction in changeover time representing a key tactical improvement. This empirical result provided a solid foundation for the Arena simulation, which subsequently scaled these micro-level gains to project a significant, system-wide increase in production plan compliance to 88.4%. The statistical analysis further reinforces these conclusions; the non-overlapping 95% confidence intervals for daily production, together with the paired t-test results, provide robust evidence that the observed increase in throughput is a direct and reliable outcome of the implemented Lean initiatives.

When placed in the context of existing literature, these results align with the expected benefits of SMED and Standardized Work. For example, a prior study reported a 34% reduction in changeover time in European food

TABLE III
POST-SIMULATION RESULTS

Component	Indicator	AS-IS	TO-BE	Obtained by simulation
Main problem	Production plan compliance	81%	90%	88.4%
Problem 1	Ink changeover time	7.34 min	6.00 min	5.85 min
Problem 2	Bottle transfer time	21.7 min	11.6 min	16.4 min
Component	Indicator	AS-IS	TO-BE	Obtained by simulation
Problem 3	Bottles produced (per shift)	4,086 units	4,320 units	4,596 units
Problem 4	Setup changeover time	60.1 min	15 min	48.7 min

manufacturing using SMED, whereas this study achieved a 20% reduction [8]. Although this improvement is more modest, it remains substantial, particularly given the minimal resource investment required for implementation. These findings indicate that even scaled-down Lean initiatives can yield meaningful performance gains. Similarly, the observed improvements in operational rhythm and task coordination are consistent with other studies reporting reduced cycle times following the application of standardized routines in packaging lines.

Ultimately, this alignment with academic evidence reinforces the validity of applying these Lean tools within small- to medium-sized food production environments. Although the magnitude of improvement may vary depending on scale and available resources, the direction of the impact remains consistently positive. The study bridges the gap between a specific operational problem and a validated, generalizable solution, demonstrating that SMED and Standardized Work are not merely theoretical constructs but practical tools for achieving measurable performance gains.

Beyond the immediate improvements, sustainability of the interventions must be ensured. A plan of continuous monitoring was proposed, including internal audits, weekly KPI reviews, and visual reports for supervisors. Operator training and the consistent use of standardized checklists were emphasized as mechanisms to foster discipline and reduce resistance to change. This not only supports the durability of the improvements but also strengthens organizational culture by embedding Lean practices into daily routines. These measures are expected to maintain production plan compliance over time and foster a continuous improvement mindset across the workforce.

A. Sustainability and Long-Term Maintainability Plan

We propose a quarterly sustainment cadence with layered process audits (LPA) emphasizing adherence to Standardized Work, changeover preparation, and safety and quality checks. A tiered metric dashboard will track: (a) production plan compliance (daily%), (b) setup/changeover time (min

per event), (c) unplanned downtime (min per shift), (d) first-pass yield (%), and (e) output per shift (boxes).

Ownership is assigned at three levels: operators (daily checklists and andon triggers), supervisors (weekly gemba reviews and skills-matrix upkeep), and the continuous improvement/industrial engineering team (monthly variance analysis, corrective actions, and refresher training).

Capability building follows a training-within-industry (TWI) approach—job breakdown sheets for critical tasks, micro-learning modules delivered on shift, and quarterly recertification on SMED roles and Standardized Work. Culture reinforcement includes visual controls at the line, public KPI boards, and recognition for teams sustaining compliance above target for three consecutive months.

V. CONCLUSIONS

The study contributes to the literature by providing causal evidence—via matched replications and a paired design—on the integrated effect of SMED and Standardized Work on plan compliance in the edible-oil sector within Latin America.

For practitioners, the following improvement sequence is recommended: (1) externalize setup tasks using a pre-changeover checklist; (2) co-locate tools and format parts at the point of use; (3) define role-based Standardized Work with clear staffing levels; and (4) establish a sustainment system incorporating LPAs, KPI visualization, and skills-matrix-driven training.

Future research may examine the generalizability of these findings across different product types and viscosity ranges, investigate interactions with Total Productive Maintenance and quick-response maintenance, and compare discrete-event simulation with digital twin approaches to better capture dynamic scheduling and multi-line coordination.

The simultaneous implementation of SMED and Standardized Work proved effective in significantly improving production plan compliance at the company.

The compliance rate increased from 81% to 88.4%, bringing performance closer to industry benchmarks. These results indicate that the Lean tools not only addressed operational inefficiencies but also enhanced the reliability and consistency of the production process.

In addition, the proposed improvements produced measurable gains in key performance indicators. Format changeover (setup) time was reduced by 19%, decreasing from 60.1 to 48.7 min, while bottle transport time declined by 24.4%, from 21.7 to 16.4 min. Moreover, production per shift increased by 12.5%, reaching 4,596 bottles. These results confirm the effectiveness of SMED and Standardized Work in enhancing operational efficiency and boosting productivity in mass-consumption manufacturing environments.

The simultaneous implementation of SMED and Standardized Work proved effective in significantly improving production plan compliance at the company. The compliance rate increased from 81% to 88.4%, bringing performance closer to industry benchmarks. These results indicate that the Lean tools not only addressed operational inefficiencies but also enhanced the reliability and consistency of the production process.

In addition, the proposed improvements had a tangible impact on key performance indicators. Format changeover (setup) time was reduced by 19%, decreasing from 60.1 to 48.7 min, while bottle transport time declined by 24.4%, from 21.7 to 16.4 min. Furthermore, the production per shift increased by 12.5%, reaching 4,596 bottles. These results confirm the effectiveness of SMED and Standardized Work in optimizing operational efficiency and boosting productivity in mass-consumption manufacturing environments.

REFERENCES

- [1] M. A. Habib, R. Rizvan, and S. Ahmed, "Implementing Lean Manufacturing for improvement of operational performance in a labeling and packaging plant: A case study in Bangladesh," *Results Eng.*, vol. 17, Art. no. 100818, Mar. 2023, doi: <https://doi.org/10.1016/j.rineng.2022.100818>
- [2] J. E. Ortiz Porras, A. M. Bancovich Erquinigo, T. C. Candia Chávez, L. M. Huayanay Palma, R. K. Moore Torres, and O. R. Tinoco Gomez, "Green Lean Six Sigma model for waste reduction of raw material in a nectar manufacturing company of Lima, Peru," *J. Ind. Eng. Manag.*, vol. 16, no. 2, pp. 169-185, Feb. 2023, doi: <https://doi.org/10.3926/jiem.4916>
- [3] S. S. Rathi, M. K. Sahu, and S. Kumar, "Implementation of Lean Manufacturing methods to improve rolling mill productivity," *Int. J. Adv. Technol. Eng. Explor.*, vol. 11, no. 111, pp. 243-256, Feb. 2024, doi: <https://doi.org/10.19101/ijatee.2023.10102004>
- [4] J. Nikolić, M. Dašić, and M. Đapan, "SMED as an indispensable part of Lean Manufacturing in the small and medium enterprises," *Int. J. Qual. Res.*, vol. 17, no. 1, pp. 255-270, Aug. 2023, doi: <https://doi.org/10.24874/ijqr.17.01-16>
- [5] A. Mortada and A. Soulhi, "Improvement of assembly line efficiency by using Lean Manufacturing tools and line balancing techniques," *Adv. Sci. Technol. Res. J.*, vol. 17, no. 4, pp. 89-109, Aug. 2023, doi: <https://doi.org/10.12913/22998624/169257>
- [6] M. Braglia, F. Di Paco, and L. Marrazzini, "A new Lean tool for efficiency evaluation in SMED projects," *Int. J. Adv. Manuf. Technol.*, vol. 127, pp. 431-446, May 2023, doi: <https://doi.org/10.1007/s00170-023-11508-9>
- [7] R. Şahin and A. Koloğlu, "A case study on reducing setup time using SMED on a turning line," *Gazi Univ. J. Sci.*, vol. 35, no. 1, pp. 60-71, Mar. 2022, doi: <https://doi.org/10.35378/gujs.735969>
- [8] M. Maalouf and M. Zaduminska, "A case study of VSM and SMED in the food processing industry," *Manag. Prod. Eng. Rev.*, vol. 10, no. 2, pp. 60-68, Jun. 2019. [Online]. Available: <https://vbn.aau.dk/en/publications/a-case-study-of-vsm-and-smed-in-the-food-processing-industry/>
- [9] M. Stapelbroek, O. A. Kilic, Y. Yang, and D. P. Van Donk, "Eliminating production losses in changeover operations: A case study on a major European food manufacturer," *Prod. Plann. Control*, vol. 35, no. 8, pp. 794-807, Oct. 2022, doi: <https://doi.org/10.1080/09537287.2022.2136041>
- [10] D. A. de J. Pacheco and G. Di Giorgio Heidrich, "Revitalising the setup reduction activities in Operations Management," *Prod. Plann. Control*, vol. 34, no. 9, pp. 791-811, Aug. 2021, doi: <https://doi.org/10.1080/09537287.2021.1964881>
- [11] D. Medyński et al., "Digital standardization of Lean Manufacturing tools according to Industry 4.0 concept," *Appl. Sci.*, vol. 13, no. 10, 6259, May 2023, doi: <https://doi.org/10.3390/app13106259>
- [12] S. Bragança and E. Costa, "An application of the Lean Production tool Standard Work," *J. Teknol.*, vol. 76, no. 1, pp. 47-53, Sep. 2015, doi: <https://doi.org/10.11113/jt.v76.3659>
- [13] W. Fazinga, F. Saffaro, E. L. Isatto, and E. Lantelme, "Implementación del trabajo estandarizado en la industria de la construcción [Implementation of Standard Work in the construction industry]," *Rev. Ing. Constr.*, vol. 34, no. 3, pp. 288-298, Dec. 2019, doi: <https://doi.org/10.4067/S0718-50732019000300288>

- [14] D. M. C. dos Santos, B. K. dos Santos, and C. dos Santos, "Implementation of a Standard Work routine using Lean Manufacturing tools: A case study," *Gestão Prod.*, vol. 28, no. 1, e4823, Feb. 2021, doi: <https://doi.org/10.1590/0104-530x4823-20>
- [15] L. Jurík, N. Horňáková, and V. Domčeková, "The application of SMED method in the industrial enterprise," *Acta Logist.*, vol. 7, no. 4, pp. 269-281, Dec. 2020, doi: <https://doi.org/10.22306/al.v7i4.189>

BIOGRAPHICAL NOTES

GONZALO MONTOYA-MARÍN

Gonzalo Montoya-Marín holds a Bachelor's degree in Industrial Engineering from Universidad de Lima. He currently works in the Purchasing Department of a leading multinational company in the food and dairy industry, recognized as one of the largest corporations in Peru and Latin America. In this role, he is involved in procurement and supply management for raw materials and inputs, continuous coordination with suppliers, and operational and administrative purchasing processes to ensure efficiency and continuity of operations. His professional interests focus on logistics, supply chain management, and operations, with a strong orientation toward process optimization and operational efficiency.

DIEGO MOGOLLÓN-SOTOMAYOR

Diego Mogollón-Sotomayor holds a Bachelor's degree in Industrial Engineering from Universidad de Lima. He currently works in the B2B Projects area at an international telecommunications company, where he participates in the planning, coordination, and management of projects for corporate clients. His professional interests include operations management, procurement, project management, and continuous process improvement.

JORGE ANTONIO CORZO-CHAVEZ

Jorge Antonio Corzo-Chavez holds a Master's degree in Business Administration from Universidad ESAN, Peru; a Master's degree in Marketing Science from ESIC Business & Marketing School, Spain; and a degree in Industrial

Engineering from Universidad de Lima, Peru. He is currently a professor in the Industrial Engineering Program at Universidad de Lima and Chief Executive Officer at Conquista Lab. He has advised industrial and service companies on productivity improvement and business model development, and has worked in entrepreneurship, innovation, and commercial roles in the construction, mining, services, and education sectors. He has co-authored papers including "Improvement of Productivity by Applying 5S, Work Standardization, Ergonomic Analysis and Poka Yoke in a Metalworking Company," published in the Proceedings of the 23rd LACCEI International Multi-Conference for Engineering, Education, and Technology; "Production Model Based on Lean Manufacturing and Systematic Layout Planning to Reduce Waste in a Company in the Poultry Sector: A Case Study," published in the International Journal of Environmental Pollution and Remediation, volume 12; and "Model for Reducing Mean Absolute Percentage Error through Smoothing and Time Series Forecasting in a Tourism SME: A Case Study," published in the Journal of Machine Intelligence and Data Science, volume 5. His main research interests are lean manufacturing, logistics, and machine learning for enterprises.

GINO VIACAVA-CAMPOS

Gino Viacava-Campos holds a Master's degree in Operations and Logistics from Universidad Peruana de Ciencias Aplicadas, Peru, and a degree in Industrial Engineering from Universidad de Lima, Peru. He is currently a professor in the Industrial Engineering Program at Universidad de Lima. He has experience in industrial and service companies, focusing on productivity improvement, business model development, and compensation system structuring. He has worked in human resources, operations, and logistics areas of a transnational company, both locally and overseas. As a consultant, he has experience in the construction, manufacturing, services, mining, commercial, finance, and education sectors. He has co-authored papers including "A Production Process Efficiency Improvement Model at a MSME Peruvian Metalworking Company," published in the Proceedings of the 2022 IEEE International Conference on Industrial Engineering and Engineering Management (IEEM). His main research interests are lean manufacturing, master production schedules, logistics, and compensation systems for small and medium-sized enterprises.

A Computer Vision-Based System for Detecting Safety Helmet Compliance on Construction Sites Using YOLOv5s

Minerva A. Paz Bodero¹ , Piero E. Suarez Chavez² 

¹t1022700821@unitru.edu.pe, t1512700521@unitru.edu.pe

^{1,2}Escuela Profesional de Ingeniería Informática, Universidad Nacional de Trujillo, Perú

Received: August 16, 2025 / Accepted: September 28, 2025 / Published: 5 June, 2026

doi: <https://doi.org/10.26439/ciii2025.8657>

ABSTRACT—The use of safety helmets is a critical measure for protecting construction workers; however, noncompliance remains a recurrent and high-risk issue. This paper presents a real-time computer vision system for helmet detection based on the YOLOv5s algorithm. The model was trained on more than 7 000 annotated images and deployed through a lightweight, scalable pipeline. Experimental results achieved a mean Average Precision (mAP at 0.5) of 91.9% and an optimal F1-score of 0.89 at a confidence threshold of 0.41, with an inference speed of 110 FPS. These findings demonstrate the system's effectiveness under real-world conditions, providing accurate and fast detection suitable for on-site safety monitoring and contributing to improved compliance in construction environments.

Index Terms—Computer vision, convolutional neural networks, deep learning, object detection, safety systems.

I. INTRODUCTION

According to 2020 data from the U.S. construction industry, the sector accounted for 21.2% of all occupational fatalities (1008 deaths) while representing only 4.1% of the total workforce, indicating that construction workers were 5.57 times more likely to die on the job than workers in other sectors [1]. In the same year, head injuries accounted for nearly 6% of nonfatal injuries resulting in days away from work [2]. These statistics highlight a critical safety gap, underscoring the importance of proper head protection—such as helmet use—in reducing the risk of severe injury.

According to 2021 U.S. data, the construction sector accounted for 25% of all occupational head injuries, making it the leading contributor to work-related traumatic brain injuries (TBIs) [3]. Falls on construction sites represented 68% of TBI cases, with falling objects contributing an additional 12% [3]. This underscores that safety helmets are not merely PPE but a critical barrier against severe injuries in high-risk occupational settings.

Several computer vision approaches have been proposed to address this issue. Hayat and Morgado-Dias [4] applied YOLOv5x to helmet detection, achieving a mean Average Precision (mAP) of 92.44% at 45 FPS, demonstrating robust performance even under low-light environments. Qian and Wang [5] introduced SHDet, a lightweight YOLOv5-based variant optimized through reverse attention and inverted residual blocks, which achieved 92.2% mAP with an inference time of only 3 ms per image, particularly suitable for embedded systems. An *et al.* [6] further improved You Only Look Once, version 5—small variant (YOLOv5s) by incorporating global attention, CBAM modules, and SIoU loss, achieving superior accuracy and speed compared to YOLOv3–v6. Li *et al.* [7] used convolutional neural networks in engineering contexts, reporting nearly 90% precision and over 85% recall, however, real-time deployment was not evaluated.

Previous research underscores the promise of deep learning techniques to enhance occupational safety; however, challenges remain regarding scalability, inference efficiency, and practical integration.

In response to this gap, this study proposes a real-time computer vision system for helmet compliance monitoring on construction sites, implemented using YOLOv5s. The main contribution is the demonstration of competitive detection accuracy with significantly higher inference speed on accessible hardware, enabling scalable deployment and supporting the enhancement of safety culture in construction environments.

II. METHODOLOGY

A. YOLOv5s Algorithm

Multiple studies indicate that YOLOv5s has evolved significantly from earlier versions, distinguishing itself through high inference speed and strong accuracy in real-time object detection [8].

Introduced by Ultralytics in 2020, YOLOv5 employs an architecture based on CSPDarknet (Cross Stage Partial, an enhanced Darknet backbone) and incorporates advanced techniques such as Mosaic Augmentation—a data augmentation strategy that combines four training images into one, improving recognition across different scales and object positions. The main steps of the YOLO detection process are summarized in the flowchart shown in Fig. 1, which illustrates the pipeline from image scaling through bounding-box prediction, confidence thresholding, and final output after non-maximum suppression.

B. Dataset

Preliminary adjustments were conducted on a small set of 45 images; however, the final training and validation were performed using an expanded dataset of 7,542 annotated images. This larger dataset ensured reliable detection of helmet use across diverse construction site conditions and scenarios.

This approach enables evaluation of the system’s validity and effectiveness under real-world situations, ensuring a high level of accuracy and reliability in safety helmet detection.

The dataset used in this study was obtained from the Roboflow platform [9], a widely used tool for dataset management and preprocessing in computer vision applications.

In this case, the YOLOv5-Hard Hat Detection Computer Vision Project was used, which includes two dataset versions comprising a total of 7,542 images depicting individuals with and without construction helmets.

These images were annotated by the dataset creator with two classes labeled *hat* and *person*.

For system development, the second version of the Roboflow dataset was selected, as shown in Fig. 2; it contains annotated images of individuals with and without safety helmets.

Examples of the labeling process are illustrated in Fig. 3, where bounding boxes identify workers in construction scenes. The dataset defines two original classes, *hat* and *person*, as illustrated in Figs. 4 and 5). For this study, these classes were relabeled as *protected* (helmet worn) and *at risk* (no helmet) to align with the project’s objectives.

C. System Design

Fig. 6 illustrates the overall workflow of the system, encompassing dataset preparation, model training, and real-time deployment.

The pipeline begins with the acquisition of training images, which undergo preprocessing steps such as normalization and resizing to enhance YOLOv5 model learning. The processed dataset is then used to train the network, enabling reliable identification of helmet use across diverse construction-site conditions.

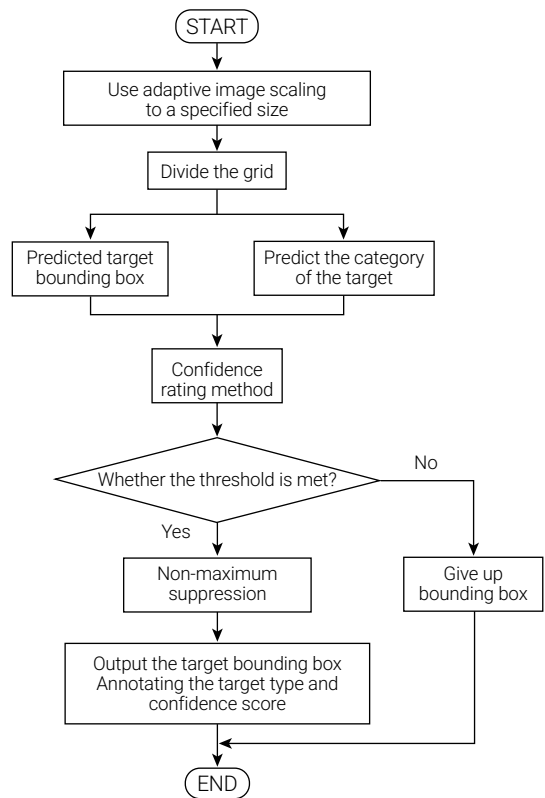

Fig. 1. Flowchart of the YOLOv5 algorithm.

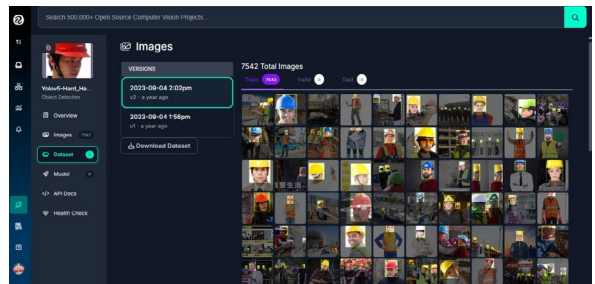

Fig. 2. Dataset used from Roboflow platform.

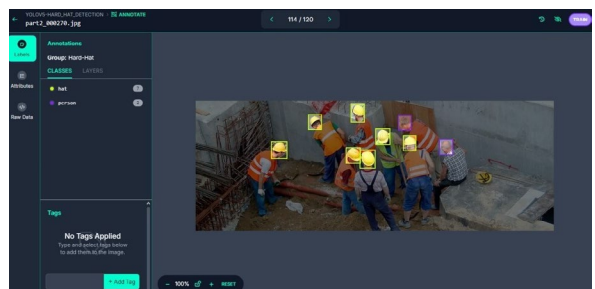

Fig. 3. Visualization of a labeled image.



Fig. 4. Visualization of the hat class.



Fig. 5. Visualization of the person class.

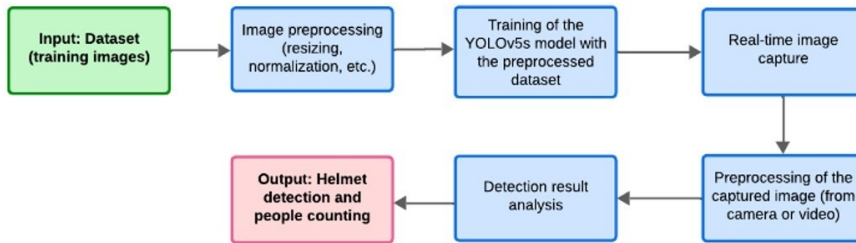

Fig. 6. Block diagram of the proposed system.

TABLE I
DISTRIBUTION OF IMAGES IN THE DATASET

Subset	Number of images
Training	4,568
Validation	2,296
Testing	678
Total	7,542

TABLE II
TRAINING CONFIGURATION PARAMETERS

Subset	Number of images
Input resolution	640 x 640
Batch size	16
Number of epochs	50
Initial weights	yolov5s.pt
Configuration file	dataset.yaml

After the training phase concludes, the workflow advances to real-time deployment. As shown in Fig. 7, images acquired from cameras or video streams undergo the same normalization steps before being analyzed by the trained model.

The system then interprets the detections, distinguishing between individuals with proper helmet use and those without protection, while also enabling personnel counting. In this way, the system not only identifies compliance but also highlights potential risks. The final stage generates outputs that support safety monitoring by providing accurate and timely information on helmet usage at construction sites.

D. Training Setup

The dataset used in this study was obtained from the Roboflow platform (YOLOv5 Hard Hat Detection v2), containing annotated images of individuals with and without safety helmets.

For the purposes of this research, the classes were relabeled as *protected* (helmet worn) and *at risk* (no helmet). Table I summarizes the number of images assigned to training, validation, and testing.

To enhance generalization, preprocessing included resizing all images to 640×640 pixels, normalization, and data augmentation (horizontal flips and brightness and contrast adjustments).

The system was implemented using the YOLOv5s model, which is well recognized for its efficiency in real-time object detection. Training was conducted in Google Colab, while deployment and testing were performed in Visual Studio Code. The experimental environment consisted of a laptop equipped with an AMD Ryzen 7 7435HS processor, 24 GB of RAM, an NVIDIA GeForce RTX 4060 GPU, and a 512 GB solid-state drive.

Table II details the key training parameters used in this work.

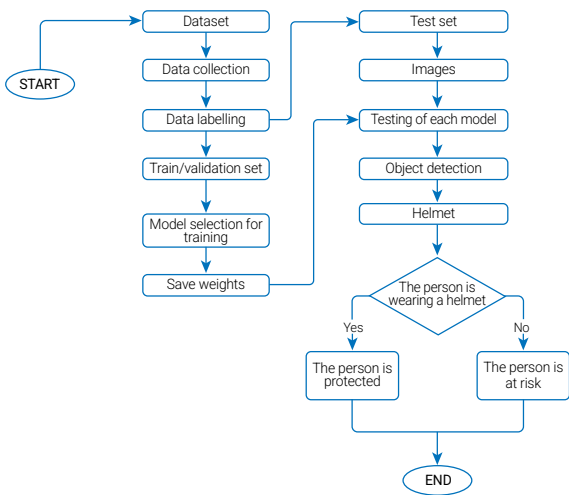

Fig. 7. Flowchart of the proposed system.

E. Metrics

The effectiveness of the proposed system was evaluated using standard object-detection metrics. Precision quantified the proportion of correct positive detections, whereas recall indicated the model's ability to identify all relevant instances. Their harmonic mean, expressed as the F1-score, served as a comprehensive metric balancing both aspects of detection quality.

A confusion matrix was also employed to visualize prediction outcomes, distinguishing correct classifications from recurrent errors and thereby helping to identify misclassification trends between the *protected* and *at risk* categories.

Furthermore, the precision-recall curve was analyzed to examine how sensitivity and specificity varied across different decision thresholds, offering additional insight into model robustness. Finally, training and validation statistics were tracked across epochs to verify stable convergence and to assess the model's generalization performance on unseen samples.

F. Scope and Limitations

The proposed system demonstrates strong performance in differentiating between individuals who comply with helmet regulations and those who do not, even under diverse environmental and lighting conditions. Its flexibility supports deployment in both indoor and outdoor construction areas, and the architecture is scalable, enabling integration with multiple cameras across large sites to achieve comprehensive coverage.

Moreover, the model can be retrained and incrementally updated with new data, enhancing its adaptability to different contexts and improving long-term robustness.

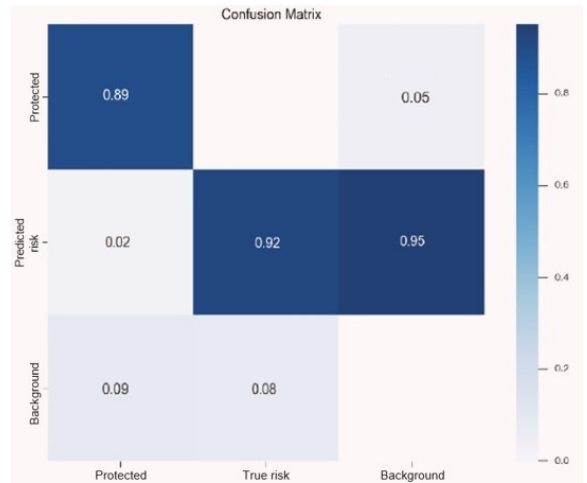

Fig. 8 Confusion matrix.

Despite these advantages, some challenges remain. False positives and false negatives may still occur, particularly when helmets are partially occluded or when visually similar objects are present.

Although YOLOv5s is considered lightweight compared to larger architectures, real-time deployment still requires adequate GPU resources, which may increase hardware costs. In addition, system accuracy may degrade under extreme lighting conditions—such as heavy shadows or excessive brightness—highlighting the need for further robustness improvements in uncontrolled environments.

III. RESULTS

A. Confusion Matrix

As shown in Fig. 8, the confusion matrix evaluates the safety-helmet detection model across three classes: *protected*, *at risk*, and *background*.

For the *protected* class, the model correctly identifies 89% of instances, with 2% being misclassified as *at risk* and 9% as *background*. The *at risk* class achieves the highest accuracy, with 92% of cases correctly detected, whereas 2% are misclassified as *protected* and 8% as *background*.

Finally, the *background* class exhibits greater confusion, with 95% accuracy; however, 5% of samples are misclassified as *protected* or *at risk*.

Overall, the confusion matrix indicates strong performance in distinguishing between the critical safety-related categories (*protected* and *at risk*), which are the most relevant for monitoring compliance in construction environments.

The slightly lower precision for the *background* class suggests that additional training data or refined annotations

could help reduce false detections in nonrelevant regions. Despite this limitation, the results confirm the model's suitability for real-time safety helmet detection and compliance monitoring at construction sites.

Fig. 9 illustrates how the F1-score varies with the confidence threshold for both the *protected* and *at risk* categories. At low confidence thresholds, the curves start at high values, reflecting strong initial detection capability.

The F1-score is defined as the harmonic mean of precision (P) and recall (R), as expressed in (1):

$$F1 = 2 \times \frac{P \times R}{P + R} \quad (1)$$

where P denotes the ratio of correctly detected positive samples to the total predicted positives, and R represents the ratio of correctly detected positives to the total actual positives.

As the threshold increases, the F1-scores gradually decline, with a more pronounced drop observed for the *at risk* class once the value exceeds 0.6. Global performance, indicated by the blue curve, peaked at a F1-score of 0.89 when the confidence threshold was set to 0.435.

This value indicates the most favorable trade-off between precision and recall, ensuring reliable detection of individuals wearing helmets. These results highlight the importance of selecting an appropriate threshold to maximize the effectiveness of the system in real-world safety-monitoring applications.

As illustrated in Fig. 10, the precision–recall relationship is shown for the classes *protected* (helmet worn) and *at risk* (no helmet). The horizontal axis represents recall, while the vertical axis indicates precision, both ranging from 0 to 1.

The curve corresponding to the *protected* class reached a precision of 0.931, whereas the *at risk* class achieved 0.907. This result suggests that the model performs slightly better in identifying individuals wearing helmets than in detecting those at risk.

The overall mAP@0.5 score of 0.919 confirms a strong trade-off between precision and recall across classes, underscoring the robustness and general effectiveness of the YOLOv5s-based detection system for construction site monitoring.

Fig. 11 summarizes the evolution of key loss functions and evaluation metrics during the training and validation of the YOLOv5s model.

The *box_loss* for both training and validation decreased steadily across epochs, indicating a continuous improvement in bounding-box localization. Similarly, the *obj_loss* followed a downward trend, reflecting the model's increasing ability to identify the presence of objects. The *cls_loss* exhibited a sharp decline in the early epochs and stabilized near zero, which denotes enhanced accuracy in classifying detected objects.

B. F1-Score

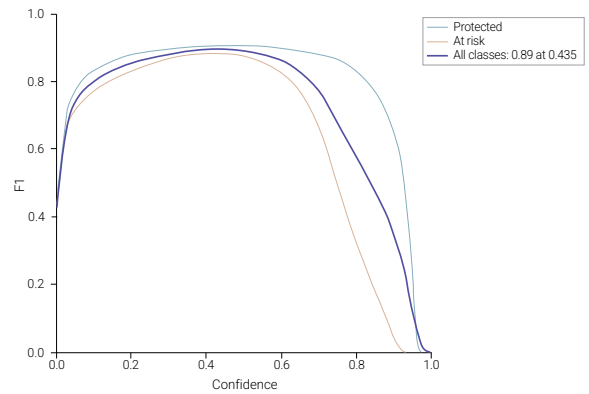

Fig. 9. F1-score.

C. Precision-Recall Curve

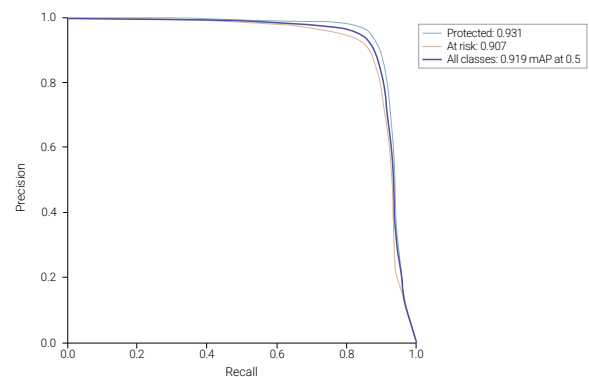

Fig. 10. Precision-recall curve.

D. Training and Validation Metrics

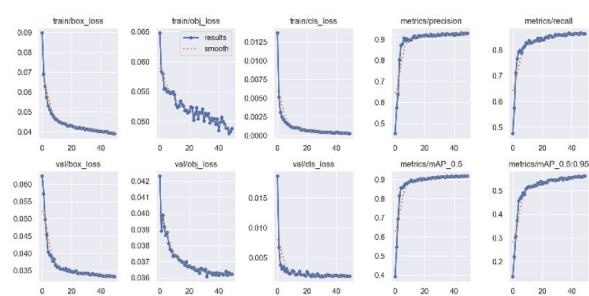

Fig. 11. Results of training and validation metrics.

Regarding performance indicators, both precision and recall improved progressively during training, reaching values close to 0.9. This trend confirms that the model became increasingly effective at producing correct detections while minimizing missed instances.

Furthermore, the mAP at an Intersection over Union (IoU) threshold of 0.5, as well as the mAP computed over the 0.5–0.95 range, increased consistently across training epochs.

These results demonstrate robust detection capability and strong generalization, underscoring the reliability of the trained YOLOv5s model in diverse operational scenarios.

E. System Demonstration

During the demonstration stage, the trained YOLOv5s model was deployed and evaluated under different real-world conditions. Validation included both video-based experiments—comprising one benchmark video and three recordings from active construction sites—and real-time testing with a webcam. These scenarios encompassed visitor entry, ongoing building activities, and worker assemblies, providing a representative sample of common construction site situations.

The deployment was carried out on a workstation equipped with an NVIDIA RTX 4060 GPU, achieving an average inference speed of 110 FPS. This ensured that the model remained resident in memory throughout the detection process, minimizing latency and enabling seamless real-time monitoring.

Figs. 12–15 illustrate representative frames captured during the demonstration phase, confirming the model’s capability to reliably distinguish between protected and at-risk individuals, labeled in Spanish as *protegido* (shown in green) and *riesgo* (shown in red) under operational conditions. These results validate the system’s suitability for live helmet compliance monitoring in construction environments.

For reproducibility and further development, the source code and implementation details of the proposed system are publicly available in a GitHub repository [10]. This allows interested researchers and developers to replicate the experiments, extend the work, or adapt the prototype to related applications.

IV. DISCUSSIONS

Compared to previous studies, this work demonstrates a tangible advancement in the detection of safety helmets within construction environments. Table III provides a comparative overview of key works in the field.

Hayat and Morgado-Dias [4] achieved 92.44% mAP with YOLOv5x but reported only 45 FPS, while our lighter YOLOv5s model reached a comparable 91.9% with more

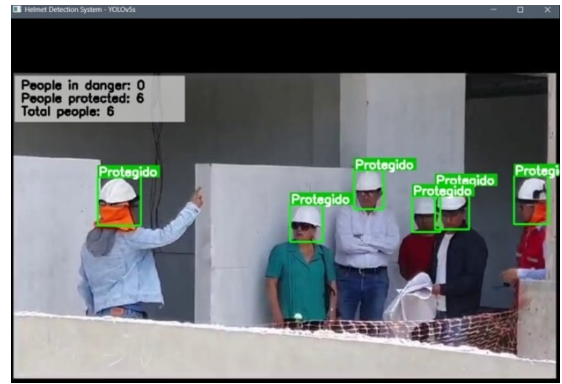

Fig. 12. Real-world site visit scenario.

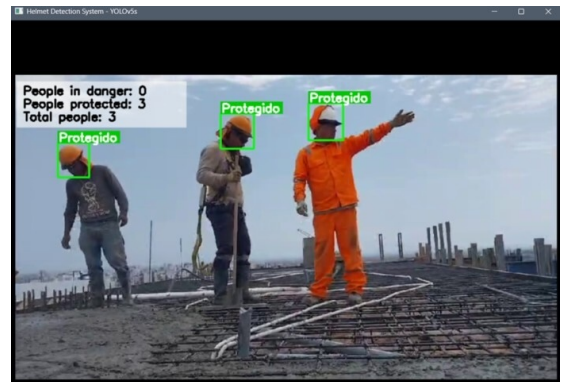

Fig. 13. Real-world construction scenario.

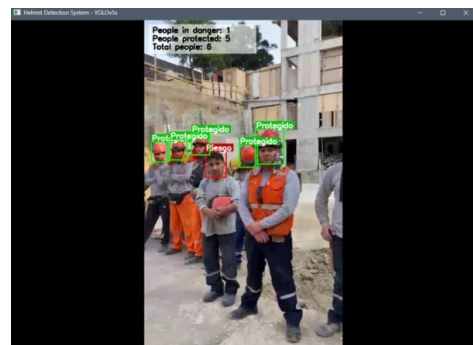

Fig. 14. Real-world worker assembly scenario.

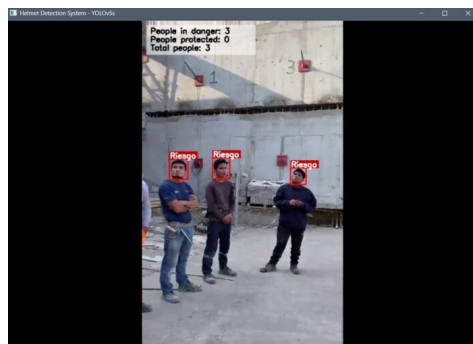

Fig. 15. Detection of at-risk workers.

than twice the processing speed (110 FPS). Qian and Wang [5] developed SHDet, optimized for embedded devices, reporting 92.2% mAP with extremely low inference time. An *et al.* [6] enhanced YOLOv5s with attention mechanisms, surpassing 93% mAP but at a higher computational cost. Li *et al.* [7] applied CNNs for helmet detection, showing good accuracy (~90%) but without validation under real-time conditions.

Unlike previous studies that focused primarily on accuracy improvements or embedded deployment, the novelty of this work lies in demonstrating that a standard YOLOv5s model, trained with a publicly available dataset, can achieve competitive accuracy while sustaining real-time inference at 110 FPS on accessible hardware. This highlights that reliable helmet compliance monitoring does not necessarily require complex model redesigns or high-end computing infrastructure, but can be deployed effectively using light-weight, scalable solutions.

Overall, our findings confirm that near state-of-the-art accuracy can be achieved with YOLOv5s while delivering superior inference speed on accessible hardware. Nevertheless, some limitations remain: false positives may occur when helmets are partially occluded or visually similar objects appear, and performance can degrade under extreme lighting or low-resolution inputs. Future work will evaluate newer architectures such as YOLOv8 or RT-DETR to determine whether accuracy gains can be achieved without sacrificing real-time performance.

In summary, this study provides a robust and efficient solution for real-time helmet compliance monitoring, striking a practical balance between detection accuracy, speed, and deployment feasibility.

V. CONCLUSION

This work presented a computer vision system for helmet compliance detection on construction sites using the YOLOv5s algorithm. The results demonstrated that the model provides accurate, real-time monitoring while maintaining high inference speed, making it a practical solution for improving occupational safety and reducing accident risks. By automating the supervision process, the system enhances regulatory compliance and alleviates the need for continuous manual oversight, contributing to more efficient site management.

The main contribution of this study is the demonstration that YOLOv5s can deliver both high detection accuracy and real-time performance on widely available hardware, offering a cost-effective and scalable alternative for construction site safety monitoring.

Future research will focus on extending detection capabilities to additional personal protective equipment such as vests, goggles, and gloves, thus broadening its safety coverage. Furthermore, the system will be tested under

TABLE III
COMPARISON OF RELATED STUDIES ON SAFETY
HELMET DETECTION

Study	Model	mAP@0.5	FPS
Hayat and Morgado-Dias [4]	YOLOv5x	92.44%	45
Qian and Wang [5]	SHDet	92.2%	-
An <i>et al.</i> [6]	YOLOv5s+	93.5%	70
Li <i>et al.</i> [7]	CNN-based	~90%	-
This work (2025)	YOLOv5s	91.9%	110

challenging environmental conditions, including low-light and adverse weather scenarios, to validate robustness. Integration with CCTV infrastructures and IoT-based alert mechanisms is also envisioned to support large-scale, real-world deployments.

REFERENCES

- [1] U.S. Bureau of Labor Statistics, "Census of fatal occupational injuries summary, 2023," U.S. Department of Labor, Washington, DC, USA, Rep., Dec. 2024. [Online]. Available: <https://www.bls.gov/news.release/cfoi.nr0.htm>
- [2] Occupational Safety and Health Administration, "OSHA announces switch from traditional hard hats to safety helmets to protect agency employees from head injuries better," U.S. Department of Labor News Release, Dec. 11, 2023. [Online]. Available: <https://www.osha.gov/news/newsreleases/trade/12112023>
- [3] M. Bottlang, G. DiGiacomo, S. Tsai, and S. Madey, "Effect of helmet design on impact performance of industrial safety helmets," *Heliyon*, vol. 8, no. 8, Art. no. e09962, Aug. 2022, doi: <https://doi.org/10.1016/j.heliyon.2022.e09962>
- [4] A. Hayat and F. Morgado-Dias, "Deep learning-based automatic safety helmet detection system for construction safety," *Appl. Sci.*, vol. 12, no. 16, Art. no. 8268, Aug. 2022, doi: <https://doi.org/10.3390/app12168268>
- [5] Y. Qian and B. Wang, "A new method for safety helmet detection based on convolutional neural network," *PLoS One*, vol. 18, no. 10, Art. no. e0292970, Oct. 2023, doi: <https://doi.org/10.1371/journal.pone.0292970>
- [6] Q. An, Y. Xu, J. Yu, M. Tang, T. Liu, and F. Xu, "Research on safety helmet detection algorithm based on improved YOLOv5s," *Sensors*, vol. 23, no. 13, p. 5824, Jun. 2023, doi: <https://doi.org/10.3390/s23135824>
- [7] Y. Li, H. Wei, Z. Han, J. Huang, and W. Wang, "Deep learning-based safety helmet detection in engineering

- management based on convolutional neural networks,” *Adv. Civ. Eng.*, vol. 2020, no. 6, pp. 1–10, Sep. 2020, doi: <https://doi.org/10.1155/2020/9703560>
- [8] Y. Li, C. Ma, L. Li, R. Wang, Z. Liu, and Z. Sun, “Lightweight tunnel obstacle detection based on improved YOLOv5,” *Sensors*, vol. 24, no. 2, p. 395, Jan. 2024, doi: <https://doi.org/10.3390/s24020395>
- [9] HelmetWearingData, “YOLOv5 hard hat detection dataset v2,” Roboflow Universe, 2023. [Online]. Available: https://universe.roboflow.com/helmetwearingdata/yolov5-hard_hat_detection/dataset/2
- [10] P. Suarez and M. Paz, “Helmet Detection Project,” GitHub Repository, 2025. [Online]. Available: https://github.com/pierosuarez29/Helmet_Detection_Project

BIOGRAPHICAL NOTES

MINERVA ANTONELLA PAZ BODERO





Minerva Antonella Paz Bodero is a tenth-cycle Computer Engineering student at Universidad Nacional de Trujillo. Her training and experience include UX/UI design focused on usability and prototyping in Figma, complemented by knowledge of web application development and database management. She has participated in applied research projects related to computer vision and process automation. She is co-author of the article “A Mobile Optical Mark

Recognition System for Pre-University Admission Tests,” accepted for publication in *Engineering Proceedings* (Scopus Q3), and of the paper “A Computer Vision-Based System for Detecting Safety Helmet Compliance on Construction Sites Using YOLOv5s,” presented at the IV International Congress of Industrial Engineering of Universidad de Lima. Her areas of interest include UX/UI design, computer vision, and the development of technological solutions for applied research.

PIERO ENRIQUE SUAREZ CHAVEZ

Piero Enrique Suarez Chavez is a tenth-cycle Computer Engineering student at Universidad Nacional de Trujillo. He has experience developing technological solutions as a full-stack developer, participating in the construction and maintenance of web systems with an emphasis on back-end, front-end, and databases, as well as process automation using Python. He has worked on projects focused on optimizing operational workflows and implementing applications with API and data service integration. He is co-author of the article “A Mobile Optical Mark Recognition System for Pre-University Admission Tests,” accepted for publication in *Engineering Proceedings* (Scopus Q3), and of the paper “A Computer Vision-Based System for Detecting Safety Helmet Compliance on Construction Sites Using YOLOv5s,” presented at the IV International Congress of Industrial Engineering of Universidad de Lima. His interests focus on software development, process automation, and the application of computer vision to safety and monitoring solutions.

Reduction of Delivery Times through Supply Chain Tools in a Company of the Chemical Sector

Ayme K. Anglas Valerio¹ , Milagros K. Rojas Bravo² , Gustavo A. Luna Victoria León³ ,
Wilson D. Calderón Gonzales⁴ 

¹20182248@aloe.ulima.edu.pe, ²20194539@aloe.ulima.edu.pe, ³galuna@ulima.edu.pe, ⁴wcalder@ulima.edu.pe

¹²³⁴Carrera de Ingeniería Industrial, Universidad de Lima, Perú

Received: August 15, 2025 / Accepted: September 20, 2025 / Published: 5 June, 2026

doi: <https://doi.org/10.26439/ciii2025.8658>

ABSTRACT—This article addresses the problem of delivery delays in a Peruvian chemical sector company, where traditional logistics operations and a low level of digitalization have resulted in economic penalties equivalent to 17.14% of its annual sales. Based on a functional and economic diagnosis, the main root causes identified were errors in materials forecasting, product deterioration, and warehouse layout disorganization. To address this issue, an improvement model was designed using Supply Chain Management (SCM) tools, integrating ABC analysis, the Odoo inventory management system, slotting, and demand forecasting. Validation using simulation and performance indicator analysis demonstrated substantial improvements, with the service level increasing from 59% to 92%, picking time reduced by 91%, and economic penalties decreasing by 83%. Furthermore, the warehouse layout redesign led to improved internal flows, reduced unnecessary travel, and more efficient use of storage space. In addition, weekly quality controls were incorporated, together with a barcode-based traceability system for real-time tracking of inventory inflows and outflows. These results confirm the effectiveness of the proposed model and provide applied evidence to optimize logistics processes in medium-sized companies in the chemical sector, contributing to the achievement of Sustainable Development Goals (SDGs) 8, 9, 12, and 13 through a low-cost, highly applicable, and potentially replicable solution in other logistics environments.

Index Terms—ABC classification, demand forecasting, inventory management, logistics, slotting.

I. INTRODUCTION

The chemical sector in Peru represents a key link in the manufacturing industry, contributing around 1.3% to national GDP and 10% to manufacturing GDP. However, its

evolution has been irregular in recent decades, conditioned by high dependence on imported inputs, low levels of technological investment, and stringent regulatory standards that increase operational complexity. In addition, growing market pressure demands improvements in efficiency, reductions in logistics costs, and faster responses to the specific requirements of strategic sectors such as mining, construction, and agribusiness.

Within this context, medium-sized companies in the sector encounter logistical difficulties stemming from manual operations, limited digitalization, and inadequate responsiveness to demand fluctuations.

Several studies and organizations, including the National Institute of Statistics and Informatics (INEI) and the National Society of Industries (SNI), have identified delivery time delays as one of the main problems in the sector. These delays are attributed to factors such as errors in demand planning, warehouse disorganization, and a lack of inventory traceability. At the international level, the scientific literature has explored solutions to these challenges through the application of Supply Chain Management (SCM) tools, highlighting techniques such as ABC analysis, slotting, demand forecasting, and the integration of digital management systems.

Nevertheless, notwithstanding the progress achieved in logistics management, the chemical sector continues to be insufficiently addressed in applied logistics studies, especially in the case of firms engaged in the commercialization of chemical inputs. According to [1], academic research has not yet delved deeply into SCM in this segment, while [2] and [3] highlight specific challenges related to storage, digitalization, and regulatory compliance. The scarcity of applied studies in this area emphasizes the relevance of this work, as it provides empirical evidence and an improvement model adapted to the operational reality of companies

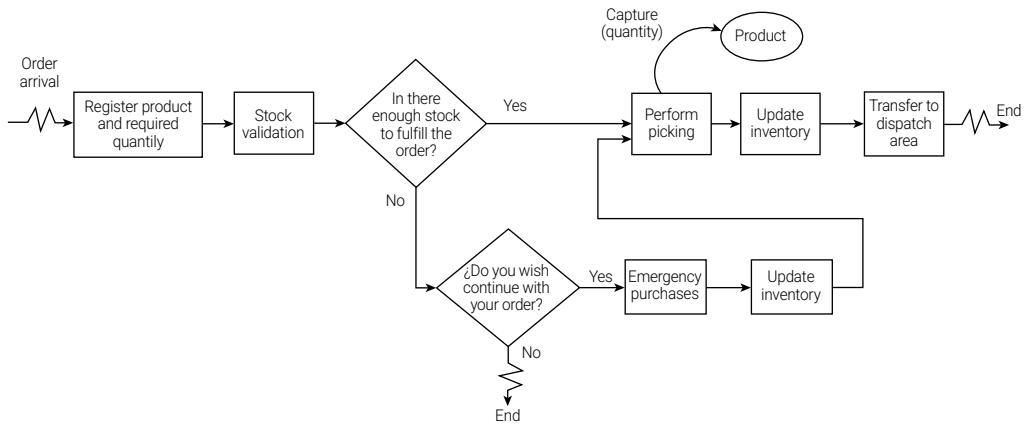

Fig. 1. Operational sequence of order management in the warehouse.

engaged in the commercialization of chemical inputs, thus contributing to narrowing the identified knowledge gap.

The company under study, dedicated to marketing specialized chemical products mainly for the mining sector, has an annual average on-time delivery (OTD) rate of only 74.5%, significantly below the sector benchmark of 95% [4]. In addition, the company has incurred economic penalties amounting to 17.14% of its annual turnover, equivalent to USD 328,600, as a result of delivery delays. The main causes identified include errors in demand forecasting, product deterioration resulting from inadequate storage conditions, and disorganization of the warehouse layout, which significantly increases the time required to locate and prepare orders. These deficiencies not only result in financial losses but also impact the company's reputation with its corporate clients, who demand high levels of contractual compliance.

The main objective of this study is to design and validate an improvement model that reduces delivery times through the implementation of SCM tools. The hypothesis posits that the integration of ABC analysis, an inventory management system, slotting strategies, and demand forecasting techniques will improve the service level, optimize logistics processes, and reduce penalty-related costs. In addition, the intervention is expected to enhance inventory movement traceability, improve operational control, and provide greater visibility into product status at each stage of the logistics process, thereby promoting more efficient management aligned with business environment requirements.

The relevance of this research lies in its contribution of empirical, actionable evidence to the logistics operations of medium-sized companies in the chemical sector, supporting operational efficiency, economic and environmental sustainability, and the achievement of SDGs 8, 9, 12, and 13.

II. METHODOLOGY

The methodology adopted in this research is applied in nature, with a descriptive-explanatory scope and a quantitative approach. The study was structured into four phases—diagnosis, design, implementation, and validation—under a systematic framework aimed at improving the logistics processes of a company in the chemical sector. Throughout the development, the objective was not only to describe the current situation and its main problems, but also to explain their underlying operational causes and propose concrete and feasible solutions. This is consistent with the approach presented in [5], where the combination of Lean and Six Sigma methodologies within supply chain processes can effectively address complex operational problems and improve overall performance.

The research focused specifically on the company's internal logistics process, with particular emphasis on warehouse management and the order fulfillment stage, as these areas exhibited the primary operational inefficiencies and customer service delays. These shortcomings impacted not only the response time, but also inventory control, interdepartmental coordination, and product traceability. Accordingly, the current flow of activities—from order receipt to dispatch readiness—was mapped to identify critical improvement points. This flow is shown in Fig. 1, which details the operational sequence of warehouse order management.

During the diagnosis phase, historical data were collected from the company's internal records, and current information was gathered using Excel recording formats, in which operational staff recorded product entry and exit times, delays causes, and associated penalties. This approach enabled the creation of a structured, organized, and comparable database for both quantitative and qualitative analysis.

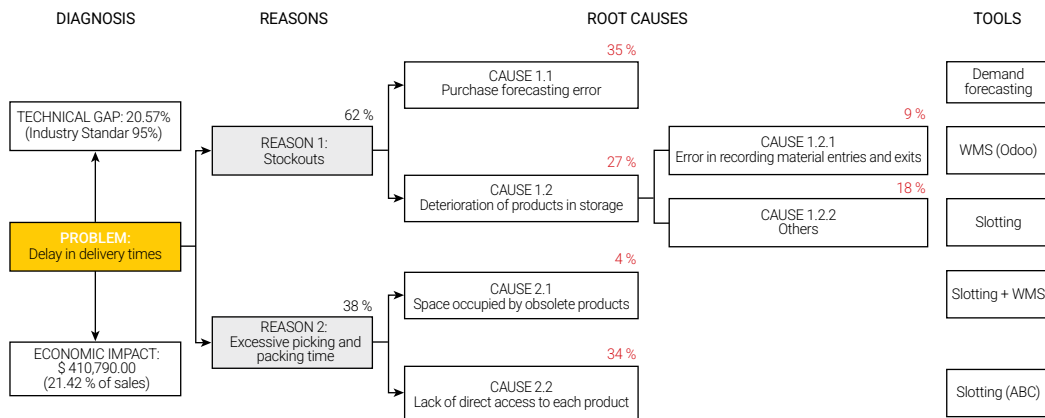

Fig. 2. Root cause problem tree - tools.

To identify the primary causes of delivery delays, classical root cause analysis tools were applied, such as the Ishikawa diagram, Pareto chart, and interviews with key personnel involved in daily logistics operations. These tools facilitated a comprehensive view of the process and allowed for the comparison of quantitative data with the team's practical experience. Through these tools, several critical factors were identified, including demand forecasting errors, product deterioration, inadequate warehouse layout design due to poor location criteria, inventory recording errors, and limited product accessibility.

In addition, a systematic literature was reviewed applying the PRISMA method, with the aim of identifying relevant approaches, tools, and results in previous studies related to logistics management.

Based on the systematic literature review, the empirical findings were contrasted with approaches previously applied in related studies, thereby providing conceptual support for the selection of the most appropriate tools and methodologies to address the logistical problems identified in the company. This contrast not only enriched the analysis but also provided a solid foundation for the construction of the problem tree, a tool that enabled the clear and structured organization of the main logistics process deficiencies, along with their root causes and consequences. This visual representation enabled the prioritization of critical aspects and guided the design of improvement proposals aligned with the actual needs of the analyzed operational context.

The case company faces significant challenges related to delivery delays, as evidenced by a low on-time delivery (OTD) level. This indicator was calculated using the following formula:

$$OTD (\%) = \left(\frac{\text{Number of orders delivered on time}}{\text{Total number of orders}} \right) \times 100 \quad (1)$$

According to analyzed data, the current OTD rate is only 74.43%, representing a gap of 20.57 percentage points relative to the 95% compliance standard established in [4]. This discrepancy indicates a significant deficiency in the company's logistics performance and underscores the need for targeted interventions to enhance responsiveness.

The total economic impact is estimated at USD 410,790.00, equivalent to 21.42% of total sales, with penalties accounting for approximately 17% of turnover, while the remaining proportion corresponds to other logistics-related costs.

As shown in Fig. 2, the primary causes identified are stockouts (62%) and prolonged picking and packing times (38%), highlighting the need for improvements in warehouse management and infrastructure.

More specifically, within the 62% attributed to stockouts, 30% is associated with purchase forecasting failures, 27% with the presence of damaged products, and 5% with inventory recording errors or internal communication failures. This distribution reflects not only limitations in physical inventory control but also deficiencies in planning processes and information capture.

Likewise, within the 38% attributed to picking and packing activities, 20% is explained by space occupied by obsolete products and 18% by inefficient item accessibility, indicating a poorly optimized layout design and an inefficient distribution that increases personnel travel times.

This situation is illustrated in Fig. 3, which shows the disorganized warehouse layout. The image depicts poor stacking practices and inefficient use of vertical space, which not only compromise safety but also hinder rapid access to products and increase the time required to locate and handle materials. These deficiencies reinforce the need for a structured and optimized storage system as part of the improvement model proposed.

As an improvement proposal, a conceptual model consisting of four integrated components was designed to optimize logistics management and reduce idle time in the warehouse.

The first component is ABC analysis, a technique that classifies products according to their turnover and strategic importance. This categorization facilitates inventory reorganization by freeing up space, optimizing picking routes, and concentrating resources on the most impactful items within the logistics operation. Moreover, ABC analysis not only enhances warehouse management but also maximizes space utilization, streamlines workflows, and contributes to the reduction of operating costs, making it a fundamental tool for achieving efficiency in logistics environments [6].

The second component corresponds to the inventory management system, implemented using Odoo as an Enterprise Resource Planning (ERP) platform, in which the Warehouse Management System (WMS) module is integrated along with reorder point-based purchasing policies. Combined, these functionalities enable digitalized operations, ensure more efficient warehouse management, and optimize supply processes.

In its role as a WMS module, Odoo incorporates a recording and virtual mapping system that enables real-time tracking of inventory inflows and outflows through barcode technology. Likewise, as an ERP platform, it directly links the sales and warehouse modules, automating order management and ensuring seamless interdepartmental coordination.

This strengthens product traceability, optimizes space utilization, and reduces risks associated with losses due to deterioration or obsolescence. Consequently, higher record accuracy is achieved, human errors are minimized, and inventory turnover becomes more agile and controlled, as reported in recent studies on ERP integration and sustainability [7].

Additionally, reorder point-based purchasing policies enable the establishment of minimum inventory thresholds per product, triggering replenishment processes when stock levels fall below these limits. This logic prevents stockouts and ensures that inventory levels remain within safe ranges, especially for high-turnover products. Likewise, it is complemented by periodic quality control activities, conducted weekly for three hours, aimed at detecting deteriorated products before they enter the logistics chain.

Finally, the choice of Odoo as the ERP platform is justified not only by its real-time integration and automation capabilities but also by its open-source nature, which makes it an accessible alternative for companies with limited resources. The implementation of open-source ERP systems, such as Odoo, has been shown to enhance organizational performance, underscoring their value as effective and cost-efficient solutions for optimizing logistics and operational processes across diverse business contexts [7].



Fig. 3. Inefficient stacking and poor space utilization in the warehouse.

The third component is the slotting technique aimed at reorganizing the physical arrangement of products in the warehouse to reduce personnel physical workload and travel times. In this reorganization, no individual product was examined; instead, the previously established ABC classification was used as a basis, grouping products according to their turnover and strategic impact. This approach enabled the redesign of the warehouse layout by placing high-turnover products (category A) in fast-access zones near the dispatch areas, while lower-frequency products (categories B and C) were allocated to less prioritized areas. In this way, operator routes were optimized, picking travel time was reduced, and a logical and functional space distribution was achieved without the need for complex or costly solutions. In low-digitalization logistics environments, techniques such as slotting have demonstrated an immediate impact by strategically assigning products within the warehouse to maximize space utilization, streamline material flows, reduce operational costs, and ensure traceability from the outset [8].

Finally, the fourth component integrates slotting with demand forecasting, using a demand forecasting through a linear regression-based forecasting model, enabling the anticipation of future demand, the prevention of stockouts, and the support of strategic decisions related to layout design and inventory replenishment. Moreover, within the Peruvian context, studies have demonstrated that the integration of statistical forecasting methods—such as Holt-Winters and SARIMA—with the economic order quantity (EOQ) model and safety stock policies can yield highly favorable results. This combination resulted in a 75%

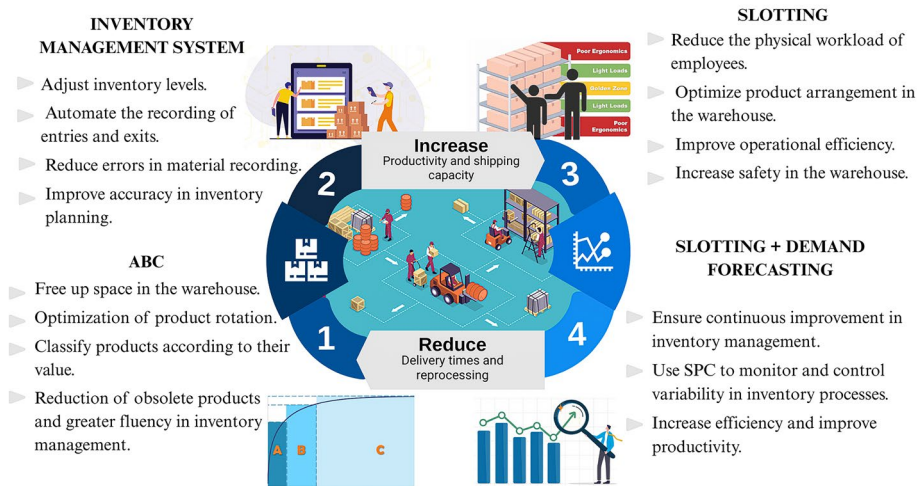

Fig. 4. Conceptual model.

reduction in stockouts, achieving a Net Present Value (NPV) of USD 9.031, an Internal Rate of Return (IRR) of 92%, and a payback period of only 59 days [9]. These results support the effectiveness of the integrated planning and replenishment models proposed in this study, reinforcing their applicability in resource-constrained environments with high operational efficiency requirements.

Together, these four elements complement each other to increase operational efficiency, reduce logistics costs, and guarantee a continuous product flow within the warehouse, as shown in Fig. 4. Their selection is warranted by their low cost, rapid implementation, and high applicability in low-digitalization logistics environments, positioning them as a practical and effective solution for medium-sized companies. Furthermore, it is acknowledged that although many companies implement ERP systems to streamline their operations, these systems can fail to integrate sustainability metrics throughout all processes. In this regard, the proposal presented in [7], based on Transaction Cost Theory, is particularly relevant, as it enables the quantification of both sustainability probabilities and potential losses by modeling processes as input-output systems, thus providing an analytical framework that complements and strengthens the logic of the implemented model.

Additionally, regulatory guidelines related to occupational health and safety in logistics operations were considered during the model design. In particular, the provisions of 29 CFR 1910.120 issued by the United States Department of Labor were taken into account, as they require employers to develop and implement a written safety and health program that enables the identification, evaluation, and control of risks, as well as the inclusion of emergency response procedures [10].

Likewise, Clause 6.1.2 of the ISO 45001 standard requires the proactive identification of workplace hazards,

along with the assessment of associated risks and opportunities, to promote a safer environment and improve the performance of the occupational health and safety management system [11]. Complementarily, under Clause 8.2 of the same standard, organizations must establish, implement, and maintain procedures to identify potential emergency situations, such as fires or chemical spills, and ensure active planning, training, regular drills, and continuous improvement of emergency response [12].

At the national level, these requirements are complemented by Law No. 29783, which mandates companies to adopt occupational risk prevention systems, strengthening preventive management through warehouse reorganization, reduction of workers' physical strain, and improvement in chemical product traceability [13].

Likewise, Law No. 30222 reinforces this regulatory framework by introducing provisions on sanctions and oversight in occupational health and safety management, which is particularly relevant for activities involving the handling of chemical substances [14].

These regulatory frameworks provided a foundation to ensure that the proposed improvements not only optimize processes but also maintain safe operating conditions in compliance with current regulations for the personnel involved.

For the implementation phase, a proposed layout was designed, as illustrated in Fig. 5, with the objective of reorganizing storage space by incorporating racks and designated areas for products classified according to the ABC analysis. This redistribution aimed to reduce travel distances, optimize product accessibility, and decrease picking times. The layout design was initially validated through a pilot test conducted on 15 selected products, proportionally distributed among Categories A, B, and C according to their share

of annual sales, to ensure the representativeness of products with the greatest impact on logistics operations.

Additionally, qualitative observations from operational staff were collected regarding accessibility, safety, and signage clarity, to adapt the layout to the actual conditions of the warehouse. This process enabled the verification of the operational feasibility of the proposed changes and allowed adjustments prior to full implementation.

In the validation phase, the unit of analysis was the orders managed by the logistics area, considering their processing times and operational incidents. A sample of 357 orders was selected using stratified sampling from the total orders recorded in 2023, ensuring the representativeness of Categories A, B, and C as defined by the ABC analysis.

Based on this, computer simulation using Arena was used to model both the current and proposed scenarios, evaluating indicators such as OTD percentage, picking times, logistics costs, and penalty amounts.

To ensure statistical robustness, 39 replications per scenario were carried out, allowing for the analysis of result variability and supporting the effectiveness of the proposed improvements. The use of Arena as a validation tool is supported by previous research [15], where the simulation of a redesigned truck dispatch layout increased daily throughput by 36% to 45%, depending on the scenario applied.

This highlights Arena's usefulness as an effective tool to evaluate alternative scenarios and support logistics decisions with quantitative evidence.

To guarantee system sustainability, a continuous improvement module was incorporated, based on statistical monitoring of demand and variability control, with periodic layout updates and automated replenishment policies.

In the initial model developed in Arena, the company's logistics system was represented using a supply scheme based on monthly purchases. However, to simulate inventory dynamics more realistically, progressive improvements were implemented in a second scenario. To realistically represent the dynamics of the logistics system, stockout events were modeled using decision blocks, while the limited inventory capacity available for each product was represented with specific simulation resources, following the methodology proposed in Simulation with Arena [16]. In addition, three differentiated processing lines were established according to the ABC classification, enabling the application of specific treatments based on turnover levels: high, medium, or low.

In this new scenario, the possibility of emergency purchases was also incorporated, activated automatically in critical stockout situations. Although these purchases allowed operations to continue, they implied an increase in logistics costs and generated additional delays in order preparation, as their arrival could take between one and two days.

To reduce the times associated with picking and stock validation, the measurements taken during the pilot test

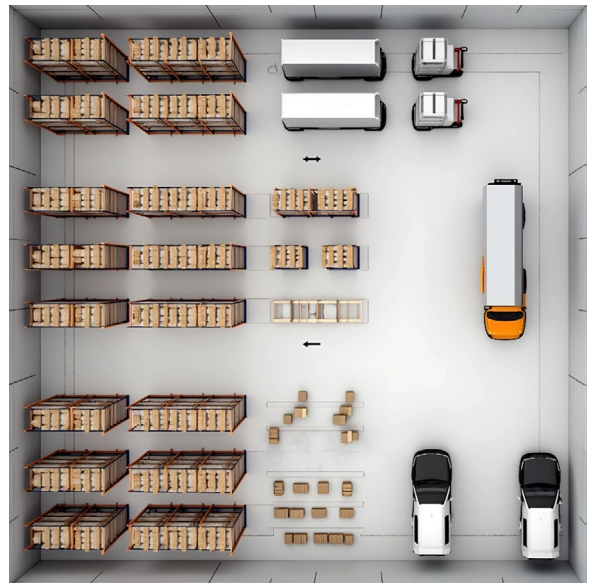

Fig. 5. Layout of the improvement model.

were used as a reference, in which the impact of the warehouse reorganization was examined under controlled conditions.

The redistribution of warehouse space, based on product rotation and accessibility criteria, enabled a reduction in staff movements during order preparation, directly decreasing total process time. In addition, the digital recording of product inflows and outflows facilitates verification of available inventory without the need for continuous physical counts.

This basic digitalization, although still limited, contributed to streamlining stock validation and enhancing inventory visibility, demonstrating that even with accessible resources, key warehouse processes can be effectively optimized.

As a complement, an automatic reordering logic was implemented, in which each product was assigned a specific reorder point according to its category (A, B, or C). When available stock fell below this threshold, the system automatically generated a purchase order, eliminating dependence on a fixed monthly supply schedule and enabling more timely and efficient replenishment.

To conclude, a quality control subprocess was integrated, implemented through the failure logic, and executed weekly for a three-hour period. This mechanism simulated the possibility that certain products might not meet the required standards, enabling the identification and isolation of deteriorated items before their inclusion in the logistics chain. Thanks to this control, a more accurate and up-to-date view of inventory availability for order fulfillment was achieved.

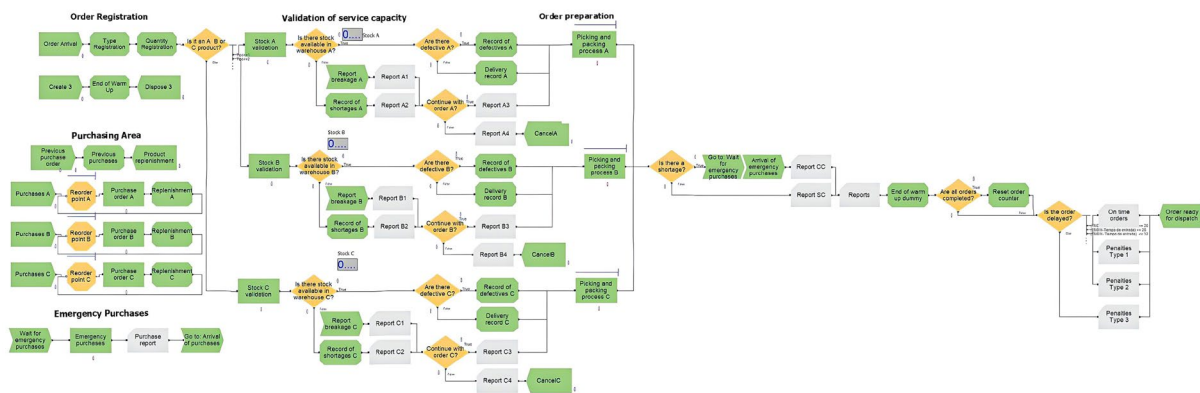

Fig. 6. Improvement simulation model.

III. RESULTS

The implementation of the improvement model yielded positive results across all key indicators. First, the OTD level increased from 74.5% to 92%, bringing logistics performance in line with industry standards. This improvement is primarily attributed to warehouse reorganization and the digitalization of inventory control.

Second, the average order preparation time decreased from 200 to 18 minutes, representing a 91% improvement. This result was achieved through slotting, which positioned high-turnover products in accessible areas, and the use of scanning devices integrated with the Odoo system.

From an economic perspective, annual penalties were reduced by 83%, from USD 328.600 to less than USD 55.000. Likewise, logistics costs associated with extra transport time decreased by 30.9% due to the elimination of urgent shipments caused by inventory errors.

Table I summarizes these results and compares key indicators before and after the implementation of the improvement model.

In addition to operational benefits, the model improved traceability, reduced product deterioration, and strengthened logistics sustainability. The integration of real-time data and automatic report generation facilitated strategic decision-making in inventory management.

IV. DISCUSSIONS

The results of this study demonstrate that implementing an integrated improvement model based on SCM tools is highly effective in logistics environments with low digitalization. Unlike isolated interventions, the sequential combination of ABC analysis, the Odoo system, slotting, and forecasting simultaneously addressed the operational, technical, and human causes of the problem.

TABLE I

COMPARISON OF INDICATORS

Indicator	Results		
	Before	After	Improvement
OTD (%)	74.5	92	+17.5%
Preparation time (min)	200	18	-91%
Annual penalties (USD)	328,600	<55,000	-83%
Service level (stock) (%)	69.7	92.4	+32%
Product access time	65 min	12 min	-81%

Prepared by authors.

The improvement in OTD, the reduction of penalties, and the optimization of storage space show that the applied tools not only correct operational errors but also enhance productivity, reducing workers’ physical strain, and improving the quality of customer service.

At a theoretical level, this study provides empirical evidence to the scarce literature on applied logistics interventions in companies marketing chemical products, a segment usually ignored by supply chain studies. In this sense, the study not only confirms the effectiveness of the applied techniques but also broadens the scope of previous research by providing a replicable framework tailored to the operational reality of this type of organization.

Finally, the environmental and social benefits derived from logistics optimization—such as reduced paper use, decreased physical strain on staff, and improved control of product deterioration—contribute to the achievement of SDGs 8 (decent work and economic growth), 9 (industry, innovation, and infrastructure), 12 (responsible consumption and production), and 13 (climate action), thereby aligning business objectives with global challenges.

V. CONCLUSION

This study demonstrated that the integration of Lean logistics tools, specifically ABC analysis, demand forecasting, and the slotting technique, alongside policies from an Integrated Management System (IMS), can significantly optimize inventory management and operational efficiency in a chemical company with low digitalization levels.

The proposed improvements effectively addressed critical issues such as stockouts, excess inventory, and inefficient warehouse layout, all without requiring a significant financial investment. The implementation of the improvement model proved highly effective in enhancing logistics performance in a low-tech environment by leveraging accessible, data-driven tools.

In terms of results, significant improvements were observed across all key indicators: the OTD rate increased from 74.5% to 92%, reducing the gap to the industry standard of 95% from 20.5% to 3%, representing an 85.4% improvement compared to the initial state. Order preparation times decreased by 91%, annual penalties fell by 83%, and the service level increased by 32%. In addition, product access time was shortened by 81%.

Beyond operational and economic benefits, the model enhanced traceability, reduced product deterioration, and minimized workers' physical strain, thereby contributing to improved working conditions. These advances also demonstrated clear alignment with SDGs 8, 9, 12, and 13 by promoting a more responsible, innovative, and sustainable approach to logistics.

Finally, this study provides valuable empirical evidence in a relatively underexplored sector, namely chemical product commercialization. Moreover, it offers a replicable and adaptable model for organizations of similar size and context seeking to enhance logistics performance through low-cost tools, integrated strategies, and data-driven decision-making.

REFERENCES

- [1] J. Juhász, "The role of industrial strategies in chemical production and service supply logistics processes," *Adv. Logist. Syst.-Theory Pract.*, vol. 18, no. 3, pp. 75–82, Oct. 2024, doi: <https://doi.org/10.32971/als.2024.030>
- [2] Miebach Consulting, "Success factor supply chain management and logistics in the chemical industry 2024," 2024. [Online]. Available: <https://www.miebach.com/us/en/news-and-resources/news-and-publications/global-miebach-chemical-logistics-study-2024>
- [3] K.-P. Jung, "Chemical logistics study 2024," *CHEManager Int.*, Sep. 11, 2024. [Online]. Available: <https://chemanager-online.com/en/news/chemical-logistics-study-2024>
- [4] *Seller Performance Standards*, Walmart, Jun. 26, 2025. [Online]. Available: <https://marketplacelearn.walmart.com/guides/Políticas%20%20standards/Performance/Seller-performance-standards>
- [5] P. Samaranayake, M. W. McLean, and S. K. Weerabahu, "Application of lean and quality improvement methods for improving operational performance in coal supply chains: A case study," *Int. J. Qual. Rel. Manag.*, vol. 41, no. 6, pp. 1594–1622, Jan. 2024, doi: <https://doi.org/10.1108/ijqrm-04-2023-0138>
- [6] J. Mira Galiana, "Método de clasificación ABC: Qué es y cómo optimizar el inventario [ABC classification method: What it is and how to optimize inventory]," *Toyota Material Handling Blog*, Nov. 8, 2022. [Online]. Available: <https://blog.toyota-forklifts.es/clasificacion-abc-para-optimizar-flujos-inventario#:~:text=La%20clasificaci%C3%B3n%20ABC%20es%20una,de%20%20manipulaci%C3%B3n%20de%20los%20art%C3%ADculos>
- [7] K. Anjaria, "Enhancing sustainability integration in Sustainable Enterprise Resource Planning (S-ERP) system: Application of Transaction Cost Theory and case study analysis," *Int. J. Inf. Manage. Data Insights*, vol. 4, no. 2, art. 100243, Nov. 2024, doi: <https://doi.org/10.1016/j.jjime.2024.100243>.
- [8] S. Arilla, "Qué es slotting o cómo aprovechar al máximo tu almacén [What slotting is and how to make the most of your warehouse]," *SCM Logística Barcelona*, Jul. 10, 2023. [Online]. Available: <https://www.scmlogistica.es/como-distribuir-almacen-que-es-el-slotting/>
- [9] A. A. Borja-Gonzales, A. B. Perez-Soto, and A. Flores-Perez, "Stockout reduction using forecasting methods, the EOQ model and a safety stock in a Peruvian SME in the commercial sector," in *Commun. Comput. Inf. Sci.*, 2024, pp. 65–75, doi: https://doi.org/10.1007/978-3-031-56373-7_6
- [10] U.S. Code of Federal Regulations. Title 29, Part 1910.120. (n.d). *Hazardous Waste Operations and Emergency Response (HAZWOPER)*. [Online]. Available: <https://www.ecfr.gov/current/title-29/subtitle-B/chapter-XVII/part-1910/subpart-H/section-1910.120>
- [11] A. Tang, "ISO 45001 Clause 6.1.2 Hazard Identification and Assessment of Risks and Opportunities," *ISO Templates and Documents Download*, Oct. 16, 2024. [Online]. Available: https://iso--docs-com.translate.goog/blogs/iso-45001-standard/iso-45001-clause-6-1-2-hazard-identification-and-assessment-of-risks-and-opportunities?_x_tr_sl=en&_x_tr_tl=es&_x_tr_hl=es&_x_tr_pto=sge#:~:text=Your%20Organization's%20Processes-,Clause%206.1.,and%20identifying%20opportunities%20for%20improvement

- [12] A. Tang, "ISO 45001 Clause 8.2 Emergency Preparedness and Response," *ISO Templates and Documents Download*, Oct. 16, 2024. [Online]. Available: <https://iso-docs.com/blogs/iso-45001-standard/iso-45001-clause-8-2-emergency-preparedness-and-response>
- [13] Congreso de la República del Perú, Ley N.º 29783, *Ley de Seguridad y Salud en el Trabajo [Occupational Safety and Health Law]*, *Diario Oficial El Peruano*, Lima, Peru, 2011.
- [14] Congreso de la República del Perú, Ley N.º 30222, *Ley que modifica la Ley de Seguridad y Salud en el Trabajo, Ley 29783 [Law Amending the Occupational Safety and Health Law, Law 29783]*, *Diario Oficial El Peruano*, Lima, Peru, Jul. 11, 2014.
- [15] A. L. Tau, E. I. Edoun, A. Pradhan, and C. Mbohwa, "Product dispatch work process line improvement using Arena simulation and modeling: A case study," in *Proc. 1st Austral. Int. Conf. Ind. Eng. Oper. Manage.*, Sydney, Australia, Dec. 20–21, 2022, pp. 375–388. [Online]. Available: <https://ieomsociety.org/proceedings/2022australia/115.pdf>
- [16] W. D. Kelton, N. B. Zupick, and N. Ivey, *Simulation with Arena*, 7th ed. New York, NY, USA: McGraw-Hill, 2024.

BIOGRAPHICAL NOTES

AYME KATHERINE ANGLAS VALERIO

Ayme Katherine Anglas Valerio holds a Bachelor's degree in Industrial Engineering from Universidad de Lima. She currently serves as a Human Resources Assistant at Corporación Cueva. She is co-author of the article "Reduction of Delivery Delays Using Supply Chain Tools in a Chemical Sector Company," presented at the IV International Congress on Industrial Engineering "AI, Operations Research, and Data Analytics" (2025), which focuses on the application of analytical tools to improve logistics performance. Her areas of interest include process improvement, sustainability, project management, supply chain management, and indicator-based decision-making.

MILAGROS KAREN ROJAS BRAVO

Milagros Karen Rojas Bravo holds a Bachelor's degree in Industrial Engineering from Universidad de Lima. She

currently works as an E-Commerce Commercial Intern at Supermercados Tottus S.A. She is co-author and presenter of the article "Reduction of Delivery Delays Using Supply Chain Tools in a Chemical Sector Company," presented at the IV International Congress on Industrial Engineering "AI, Operations Research, and Data Analytics" (2025), which focuses on the application of analytical tools to improve logistics performance. Her areas of interest include data analytics applied to business management, e-commerce, supply chain management, strategic planning, and indicator-based decision-making.







GUSTAVO ADOLFO LUNA VICTORIA LEÓN

Gustavo Adolfo Luna Victoria León is a doctoral candidate in Global Business Administration at Universidad Ricardo Palma. He holds a Master's degree in Business Administration from Universidad del Pacífico and a Bachelor's degree in Industrial Engineering from Universidad de Lima. He is a certified Project Management Professional (PMP) and Scrum Master. He currently serves as a professor in the Industrial Engineering Program at Universidad de Lima. He has more than 30 years of experience leading consultative sales, operations, and large-scale technology projects for companies such as Telefónica del Perú and GMD, serving both the public and private sectors. He specializes in high-value B2B account management. He has co-authored the articles "The Production Master Plan and Uncertainty in the Manufacturing Sector: A Literature Review" and "Scientific Research on Graphene in the Construction Industry," both published in the *Ingeniería Industrial* journal of Universidad de Lima. His research interests include industrial engineering improvement solutions, project management, and applications of artificial intelligence, particularly in project management.

WILSON DAVID CALDERÓN GONZALES

Wilson David Calderón Gonzales is a doctoral candidate in Business Administration at Universidad de Lima. He holds a Master's degree in Strategic Business Administration from Centrum Católica and a degree in Industrial Engineering from Universidad de Lima. He currently serves as Operations Manager for a Movistar franchise and as a professor in the Industrial Engineering Program at Universidad de Lima. He is a member of the Beta Gamma Sigma international honor society. His research interests include consumer experience, operations management, and process improvement.

Real-Time Recognition of Peruvian Sign Language Using Convolutional Neural Networks (CNNs)

Sonia J. León-Jimenez¹ , Claudia León-Chavarri² , Rafael Chavez-Ugaz³ , Lucia B. Suni-Chavez⁴ ,
Fabricio H. Paredes-Larroca⁵ , Ezilda M. Cabrera-Gil⁶ 

¹(20201141@aloe.ulima.edu.pe), ²(cleon@ulima.edu.pe), ³(rchavezu@ulima.edu.pe), ⁴(20194642@aloe.ulima.edu.pe),
⁵(fparedes@ulima.edu.pe), ⁶(ecabrera@ulima.edu.pe)

¹²³⁴⁵⁶ Carrera de Ingeniería Industrial, Universidad de Lima, Perú

Received: 15 August, 2025 / Accepted 5 September, 2025 / Published: 5 June, 2026
<https://doi.org/10.26439/ciii2025.8660>

ABSTRACT—Inclusive education for people with hearing impairments in many countries still lacks accessible technological tools. This work introduces a prototype for automatic translation of the Peruvian Sign Language (PSL) finger alphabet based on convolutional neural networks (CNNs) combined with support vector machines (SVMs). The system recognizes letters in real time without requiring additional sensors or wearable devices. A proprietary dataset containing up to 50 images per class was used for training under controlled conditions. The prototype achieved an average accuracy of 97%, a word error rate (WER) of 15%, and a response time of 1.8–2.0 s and a processing speed of up to 125 frames per second (fps). These results demonstrate the viability of the system as an inclusive educational tool in both controlled environments and real-life school settings.

Index Terms—Assistive technology, convolutional neural networks (CNNs), inclusive education, Peruvian Sign Language (PSL), sign language recognition.

I. INTRODUCTION

The inclusion of people with hearing disabilities in the education system continues to be a considerable challenge worldwide, especially in developing countries such as Peru [1]. Despite various institutional efforts, deaf students continue to face persistent barriers, including a shortage of qualified interpreters, limited teacher training in the use of Peruvian Sign Language (PSL), and the low availability of inclusive technological tools [1], [2], [3].

According to the World Health Organization (WHO), approximately 5% of the world's population—about 430 million people—live with significant hearing loss, a figure that is projected to increase to one in ten people by 2050 [7]. In Peru, children living in poverty are at increased risk

of hearing impairment, partly due to untreated middle ear disease and limited access to pediatric ear care, which is associated with worse academic performance [22]. In low- and middle-income countries, people with hearing loss frequently experience restricted access to education, employment and health services, leading to substantial psychosocial burden [8]. Limited access to appropriate language in deaf children can lead to delays in language development, which can cause academic problems and social exclusion. These challenges can also influence emotional development, particularly in contexts where there are communication barriers that restrict interaction with colleagues or educators. [9]. In the long term, the educational barriers can negatively impact the academic outcomes, social participation and inclusion in society. [10].

In response to this problem, deep learning-based technologies, such as CNNs, have demonstrated remarkable effectiveness in visual recognition tasks, including automatic sign interpretation [4], [13], [14]. CNNs are particularly suitable for real-time applications as they enable efficient processing and faster inference compared to traditional computer vision approaches [14], [16]. Recent studies indicate that the integration of CNNs with techniques such as support vector machines enhances classification accuracy for highly similar gestures, thereby increasing their applicability in educational contexts [14], [17].

Currently, several prototypes aimed at improving communication for people with hearing disabilities have been proposed, using a variety of technologies, as described and illustrated in Fig. 1. However, many of these approaches exhibit adaptability limitations and rely on wearable devices, such as sensorized gloves, whose accuracy typically ranges from 93.4% to 96% under standard conditions [5], [6]. Although some studies using specialized sensors have achieved accuracies of up to 96% in controlled scenarios [5], [6], these solutions remain intrusive, expensive, and

impractical for deployment in conventional classroom environments. In contrast, international studies based on computer vision and CNN models report more consistent accuracies, typically >90% accuracy, in some controlled scenarios above 95% [4], [13], Using polynomial classifiers, recognition accuracy can range from 93.41% to 98.4%, depending on the number of training patterns [25]. These findings indicate that non-invasive and context-aware approaches represent a more viable and relevant alternative, thereby reinforcing the proposed approach of this study.

This project proposes an autonomous, portable, and non-intrusive tool capable of recognizing PSL gestures in real time and automatically translating them into text and voice, without requiring gloves or an internet connection. Using an HD camera and local processing on a computer with an integrated GPU, the proposed system is positioned as an accessible alternative for public educational institutions. Unlike models based on international datasets (ASL, ISL) [11], [17], this prototype will be trained using data specific to the Peruvian context, thereby increasing its relevance and accuracy in national scenarios. It is expected to achieve an average accuracy in the range of 95% to 99%, a word error rate (WER) of approximately 15%, and a response time of no more than 2.5 s, so that the tool can effectively contribute to the educational inclusion of people with hearing disabilities through a scalable, accessible, and adaptable solution to the Peruvian school system.

A. Prototypes Based on Virtual Dictionaries and Educational Platforms

One of the most relevant developments in the national context is the PSL (PUCP) Virtual Bilingual Dictionary, which enables the translation of approximately 750 words from Spanish into sign language through manual on-screen selection [2]. Another example is *Yapaykuy*, a mobile application that converts speech to text and text to speech, with plans to incorporate predefined gesture recognition [3]. These initiatives have favored basic access to sign language; however, their operation remains static and does not support real-time visual recognition. Furthermore, these solutions rely on limited databases and do not facilitate natural interaction in dynamic educational contexts, reflecting the gaps that still exist in inclusive education in Peru [1], as well as the international challenges reported in terms of accessibility and educational outcomes for people with hearing disabilities [7]–[10].

- Comparative technical attributes are summarized as follows:
- Input: Manual selection; no automatic visual recognition [2] [3].
- Output: Text and speech; gestural fluidity is not considered [2].
- Limitation: They depend on closed databases without real-time scalability [1] [7].

B. Prototypes Based on Physical Devices (Gloves, Sensors and Wearables)

At the international level, some developments have used physical devices such as sensorized gloves to capture hand movements. Promising recognition performance in controlled settings has been approached by wereable instrumented gloves and inertial sensors; however, they require calibration and may reduce the comfort and portability in an educational environment. Although these solutions have achieved accuracies of 96.3% in segmented samples and 91.2% in real time—and in some cases up to 96% when using specialized sensors— [5], [6], they present limitations in terms of cost, user comfort, and the need for constant calibration. Furthermore, several studies have indicated that deaf people prefer non-intrusive technologies that respect their natural body language [12]. In this sense, although technically effective, gloves interfere with natural gestures and are impractical for prolonged use in educational environments.

- Comparative technical attributes are summarized as follows:
- Accuracy: >90%, but dependent on calibration, hardware used and constant maintenance [5] [6].
- Cost: high because it requires specialized hardware [5] [6].
- Limitation: They interfere with natural gestures and reduce comfort in a classroom [12].

C. Prototypes Based on Visual Recognition With Machine Learning

The latest systems use deep learning models, such as CNNs, trained on gesture images. Examples include SignNet and BranTNet—the latter based on transfer learning—which have been designed for sign languages such as ASL or ISL, using high-quality standardized datasets [4], [11], [13], [14]. These models have reported accuracies ranging from 93% to 98% under controlled conditions [4], [13], [25]. However, these models typically require large volumes of data, connectivity to external servers, and training in cultural contexts different from that of Peru. Furthermore, in many cases, they focus exclusively on isolated letters or words, without considering sentence-level structure or the particularities of the PSL [11], [17].

Comparative technical attributes are summarized as follows:

- Accuracy: above 90% under controlled conditions [4], [13], [25].
- Requirements: large volumes of data and connectivity with external servers [11], [17].
- Limitation: trained in international contexts, without considering particularities of the PSL [11], [17].

II. METHODOLOGY

Quality Function Deployment (QFD) was used as a comparative analysis tool, allowing the attributes that the proposed prototype must address to be evaluated against existing solutions. To this end, the main user requirements were reviewed: clear and accessible visualization, real-time gesture recognition, portability and ergonomics, simultaneous audio and video feedback, and adaptation to the PSL. Each requirement was assigned a weighting based on its relevance, and the performance of the proposed prototype was compared with that of several international patents [19], [20], [21].

The results show that the proposed system achieved the maximum score across all criteria, achieving 97% accuracy, operating in real time at 125 fps, working with a standard, low-cost, non-intrusive camera, offering immediate visual and auditory feedback, and being trained on a proprietary PSL dataset, thereby ensuring cultural relevance. The dataset was generated under controlled but variable conditions, using a 1080p webcam to capture the 28 letters of the PSL, including “Ñ”, with at least 50 images per class. Data acquisition sessions were conducted on different days, introducing variations in lighting, distance, and hand orientation to better simulate real-world environments. Gesture references were obtained through direct visual observation in a Peruvian Sign Language (PSL) school and were subsequently replicated during data collection, ensuring that the captured samples reflected the authentic characteristics of the local context. In contrast, the reviewed patents, while reporting accuracies above 90%, rely on gloves or other specialized devices, provide partial feedback, and focus on foreign sign languages, thereby limiting their ergonomics, accessibility, and applicability to the Peruvian context.

The proposed modular system for PSL translation consists of various phases that integrate computer vision and deep learning techniques. The main performance indicators targeted were: achieving an accuracy between 95% and 99 %, ensuring real-time operation with a minimum speed of 120 fps, maintaining a response time of less than 2 s, obtaining a WER of no more than 15% in dynamic sequences, and ensuring system non-intrusiveness through the use of a low-cost, standard camera adapted to the PSL context.

The experimentation phases followed a validation protocol widely used in computer vision [13], [14], consisting of dividing the dataset into 80% for training and 20% for testing, ensuring the evaluation of the model with data not seen during learning. In contrast, previous studies based on LSTM architectures have evaluated performance using sequence-based metrics such as BLEU, ROUGE, and CIDEr [15]. In real-time experiments, the system response rate in frames per second (fps) was also measured, and a five-frame moving average was applied to smooth predictions, thus stabilizing the output and reducing instantaneous

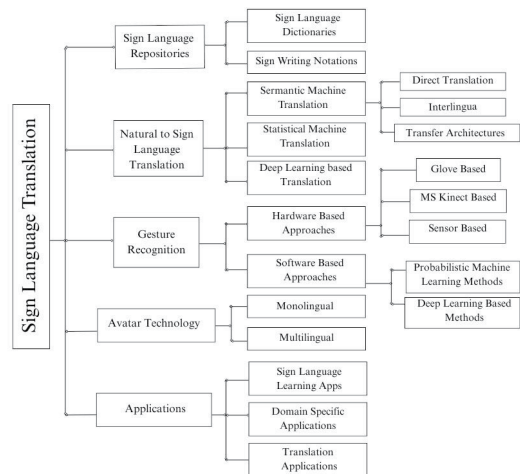

Fig. 1. Assistive technology for people with hearing impairments.

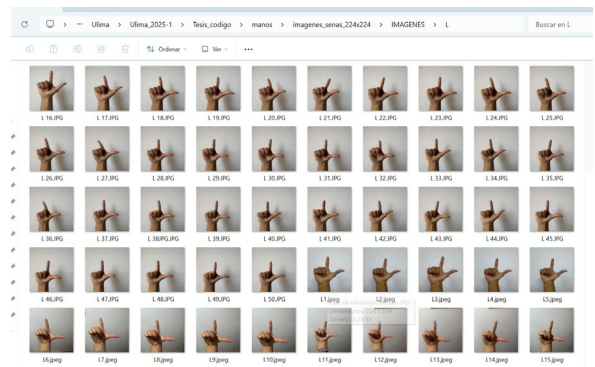

Fig. 2. Dataset of letter L.

classification fluctuations, improving output stability and reducing instantaneous classification fluctuations.

The experimental process was progressively designed in three phases, using 5, 15 and 50 images per class. This strategy enabled the evaluation of the impact of dataset size on the model's generalization capability. The deep learning literature indicates that small datasets tend to induce overfitting, which limits the system's ability to recognize new variations in the samples [13], [14]. In the first phase, using only five images per class, the model exhibited low accuracy and high classification instability. In the second phase, with 15 images per class, a substantial improvement in prediction stability was observed, reflecting increased diversity in the training samples. Finally, in the third phase, using 50 images per class, the system achieved its best performance, attaining a competitive level of accuracy consistent with that reported in international CNN-based sign recognition studies, where accuracies exceed 90% on larger datasets [4].

A. Data Collection and Use of Formulas

A proprietary dataset was constructed from video captures acquired with a high-resolution webcam (1080p at 30 fps), focusing exclusively on the user's hands against a neutral background. For each of the 28 letters of the PSL alphabet, including “Ñ”, a minimum of 50 images per class were captured, as shown in Fig. 2. Sessions were conducted on different days, with intentional variations in lighting, distance, and orientation to ensure diversity and improve model generalization, as recommended in [13].

For letters involving movement, such as “J”, “Ñ”, and “Z”, video sequences were recorded and segmented into individual frames at a rate of 5-10 fps, following a strategy similar to that used in DeepASLR [14] and in the hybrid architectures described in [17], as illustrated in Fig. 3.

B. Preprocessing

The preprocessing pipeline consisted of several stages, including conversion to grayscale to reduce computational complexity, resizing to 64x64 pixels to standardize the input of the models, and normalization of pixel values in a range between 0 and 1. Additionally, data augmentation techniques were applied, such as random rotation, translation, horizontal mirroring, and brightness modification, with the aim of increasing system robustness to real-world environmental variations. This strategy follows the approach suggested in [23] for LSTM-based models trained with augmented data. The corresponding Python code is as follows:

```
def preprocesar_frame(frame):
    roi=frame[ROI_TOP_LEFT[1]:ROI_BOTTOM_
             RIGHT[1],ROI_TOP_LEFT[0]:ROI_BOTTOM_
             RIGHT[0]]
    resized=cv2.resize(roi,(IMG_WIDTH,IMG_HEIGHT))
    normalized = resized / 255.0
    return np.expand_dims(normalized, axis=0), roi
```

C. Model Architecture

The basic architecture for static sign recognition consisted of a CNN with three convolutional layers, intermediate pooling layers, ReLU activation functions, and a final fully connected layer with SoftMax for multiclass classification as illustrated in Fig. 4. To improve accuracy for gestures with a high degree of similarity (e.g., “M” and “N”), a SVM classifier was integrated as a post-feature extraction stage, functioning as a refined decision layer, as proposed in [14].

In parallel, CNN-LSTM architecture was implemented for dynamic letters. This model receives a sequence of images (consecutive frames of the same gesture) as input and learns to capture temporal progression through recurrent layers. This approach is supported by works such as [17].

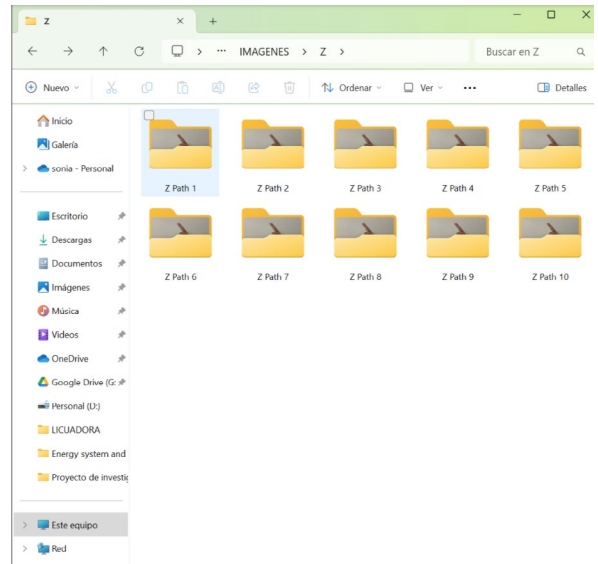

Fig. 3. Dataset of letter Z.

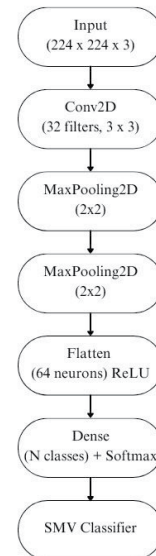

Fig. 4. Block diagram illustrating the operation of the model architecture.

D. Real-Time Integration and Execution

The system was implemented in Python using libraries such as OpenCV for video capture, TensorFlow/Keras for model training and deployment, and Pytsx3 for text-to-speech synthesis. During execution, the camera continuously detects the region of interest (ROI) corresponding to the user's hands and processes each frame in real time. The model predicts the corresponding class and accumulates the recognized letters, as illustrated in Fig. 5. A temporal segmentation

algorithm based on pauses between gestures enables the differentiation of individual letters, words, or complete phrases. The resulting text is displayed on the screen using a simple graphical interface and can be automatically converted into speech, facilitating immediate communication between the user and their environment, as shown in Fig. 6.

E. Testing, Validation and Metrics

From a statistical perspective, the validity of the performance metrics is directly influenced by the size of the test sample. With the current configuration of 50 images per class (28 letters, for a total of 1400 images) and an 80/20 training-testing split, the test set comprised approximately 280 samples. This number allows estimating the overall accuracy with a confidence interval close to $\pm 6-7\%$ at 95% confidence, which is acceptable for an experimental prototype. However, the literature suggests that reducing the margin of error to $\pm 5\%$ requires at least 384 test samples [13], [14] Likewise, for per-class metrics such as precision or recall, it is recommended to have a sufficient number of validation samples per category to ensure the statistical reliability of per-class metrics such as precision and recall. With 50 images per class, the system obtains, on average, about ten test samples per letter, which limits the statistical stability of these metrics. Therefore, as future work, it is proposed to expand the dataset to 100-150 images per class or to apply stratified *k*-fold cross-validation in order to increase the reliability of results.

The prototype was also subjected to alpha and beta testing with volunteer users to evaluate performance under both controlled conditions and real-world environments. Accuracy, sensitivity, and the confusion matrix were used for static models, while for dynamic letters, the WER was used together with sequence-level precision and recall, following the guidelines proposed in DeepASLR [14]. Response time was measured by directly timing the interval between image acquisition and prediction output, to determine an average processing speed of 125 fps, which confirms the system's real-time viability, as shown in Fig. 7.

III. RESULTS

The prototype developed for the automatic translation of the PSL finger alphabet achieved an overall accuracy of 97% using a dataset of 50 images per class, together with a WER of 15% and an average response time of 1.8-2.0 s with a processing speed of 125 frames per second, thereby confirming its viability for real-time operation. Tests were conducted under controlled laboratory conditions, with stable lighting (300 lumens/250 lux), a uniform background, and minimal visual interference, thereby ensuring that the observed variations were attributable to the model's performance rather than to external factors.

The class-wise analysis showed that letters with distinctive features (L, T, and Y) achieved accuracies above 95%,

The image shows a MATLAB script for training a neural network. It includes steps for loading data, normalizing, splitting into training and testing sets, defining a neural network architecture with layers like 'conv_1', 'conv_2', 'conv_3', 'conv_4', 'conv_5', 'conv_6', 'conv_7', 'conv_8', 'conv_9', 'conv_10', 'conv_11', 'conv_12', 'conv_13', 'conv_14', 'conv_15', 'conv_16', 'conv_17', 'conv_18', 'conv_19', 'conv_20', 'conv_21', 'conv_22', 'conv_23', 'conv_24', 'conv_25', 'conv_26', 'conv_27', 'conv_28', 'conv_29', 'conv_30', 'conv_31', 'conv_32', 'conv_33', 'conv_34', 'conv_35', 'conv_36', 'conv_37', 'conv_38', 'conv_39', 'conv_40', 'conv_41', 'conv_42', 'conv_43', 'conv_44', 'conv_45', 'conv_46', 'conv_47', 'conv_48', 'conv_49', 'conv_50', 'conv_51', 'conv_52', 'conv_53', 'conv_54', 'conv_55', 'conv_56', 'conv_57', 'conv_58', 'conv_59', 'conv_60', 'conv_61', 'conv_62', 'conv_63', 'conv_64', 'conv_65', 'conv_66', 'conv_67', 'conv_68', 'conv_69', 'conv_70', 'conv_71', 'conv_72', 'conv_73', 'conv_74', 'conv_75', 'conv_76', 'conv_77', 'conv_78', 'conv_79', 'conv_80', 'conv_81', 'conv_82', 'conv_83', 'conv_84', 'conv_85', 'conv_86', 'conv_87', 'conv_88', 'conv_89', 'conv_90', 'conv_91', 'conv_92', 'conv_93', 'conv_94', 'conv_95', 'conv_96', 'conv_97', 'conv_98', 'conv_99', 'conv_100', 'conv_101', 'conv_102', 'conv_103', 'conv_104', 'conv_105', 'conv_106', 'conv_107', 'conv_108', 'conv_109', 'conv_110', 'conv_111', 'conv_112', 'conv_113', 'conv_114', 'conv_115', 'conv_116', 'conv_117', 'conv_118', 'conv_119', 'conv_120', 'conv_121', 'conv_122', 'conv_123', 'conv_124', 'conv_125', 'conv_126', 'conv_127', 'conv_128', 'conv_129', 'conv_130', 'conv_131', 'conv_132', 'conv_133', 'conv_134', 'conv_135', 'conv_136', 'conv_137', 'conv_138', 'conv_139', 'conv_140', 'conv_141', 'conv_142', 'conv_143', 'conv_144', 'conv_145', 'conv_146', 'conv_147', 'conv_148', 'conv_149', 'conv_150', 'conv_151', 'conv_152', 'conv_153', 'conv_154', 'conv_155', 'conv_156', 'conv_157', 'conv_158', 'conv_159', 'conv_160', 'conv_161', 'conv_162', 'conv_163', 'conv_164', 'conv_165', 'conv_166', 'conv_167', 'conv_168', 'conv_169', 'conv_170', 'conv_171', 'conv_172', 'conv_173', 'conv_174', 'conv_175', 'conv_176', 'conv_177', 'conv_178', 'conv_179', 'conv_180', 'conv_181', 'conv_182', 'conv_183', 'conv_184', 'conv_185', 'conv_186', 'conv_187', 'conv_188', 'conv_189', 'conv_190', 'conv_191', 'conv_192', 'conv_193', 'conv_194', 'conv_195', 'conv_196', 'conv_197', 'conv_198', 'conv_199', 'conv_200', 'conv_201', 'conv_202', 'conv_203', 'conv_204', 'conv_205', 'conv_206', 'conv_207', 'conv_208', 'conv_209', 'conv_210', 'conv_211', 'conv_212', 'conv_213', 'conv_214', 'conv_215', 'conv_216', 'conv_217', 'conv_218', 'conv_219', 'conv_220', 'conv_221', 'conv_222', 'conv_223', 'conv_224', 'conv_225', 'conv_226', 'conv_227', 'conv_228', 'conv_229', 'conv_230', 'conv_231', 'conv_232', 'conv_233', 'conv_234', 'conv_235', 'conv_236', 'conv_237', 'conv_238', 'conv_239', 'conv_240', 'conv_241', 'conv_242', 'conv_243', 'conv_244', 'conv_245', 'conv_246', 'conv_247', 'conv_248', 'conv_249', 'conv_250', 'conv_251', 'conv_252', 'conv_253', 'conv_254', 'conv_255', 'conv_256', 'conv_257', 'conv_258', 'conv_259', 'conv_260', 'conv_261', 'conv_262', 'conv_263', 'conv_264', 'conv_265', 'conv_266', 'conv_267', 'conv_268', 'conv_269', 'conv_270', 'conv_271', 'conv_272', 'conv_273', 'conv_274', 'conv_275', 'conv_276', 'conv_277', 'conv_278', 'conv_279', 'conv_280', 'conv_281', 'conv_282', 'conv_283', 'conv_284', 'conv_285', 'conv_286', 'conv_287', 'conv_288', 'conv_289', 'conv_290', 'conv_291', 'conv_292', 'conv_293', 'conv_294', 'conv_295', 'conv_296', 'conv_297', 'conv_298', 'conv_299', 'conv_300', 'conv_301', 'conv_302', 'conv_303', 'conv_304', 'conv_305', 'conv_306', 'conv_307', 'conv_308', 'conv_309', 'conv_310', 'conv_311', 'conv_312', 'conv_313', 'conv_314', 'conv_315', 'conv_316', 'conv_317', 'conv_318', 'conv_319', 'conv_320', 'conv_321', 'conv_322', 'conv_323', 'conv_324', 'conv_325', 'conv_326', 'conv_327', 'conv_328', 'conv_329', 'conv_330', 'conv_331', 'conv_332', 'conv_333', 'conv_334', 'conv_335', 'conv_336', 'conv_337', 'conv_338', 'conv_339', 'conv_340', 'conv_341', 'conv_342', 'conv_343', 'conv_344', 'conv_345', 'conv_346', 'conv_347', 'conv_348', 'conv_349', 'conv_350', 'conv_351', 'conv_352', 'conv_353', 'conv_354', 'conv_355', 'conv_356', 'conv_357', 'conv_358', 'conv_359', 'conv_360', 'conv_361', 'conv_362', 'conv_363', 'conv_364', 'conv_365', 'conv_366', 'conv_367', 'conv_368', 'conv_369', 'conv_370', 'conv_371', 'conv_372', 'conv_373', 'conv_374', 'conv_375', 'conv_376', 'conv_377', 'conv_378', 'conv_379', 'conv_380', 'conv_381', 'conv_382', 'conv_383', 'conv_384', 'conv_385', 'conv_386', 'conv_387', 'conv_388', 'conv_389', 'conv_390', 'conv_391', 'conv_392', 'conv_393', 'conv_394', 'conv_395', 'conv_396', 'conv_397', 'conv_398', 'conv_399', 'conv_400', 'conv_401', 'conv_402', 'conv_403', 'conv_404', 'conv_405', 'conv_406', 'conv_407', 'conv_408', 'conv_409', 'conv_410', 'conv_411', 'conv_412', 'conv_413', 'conv_414', 'conv_415', 'conv_416', 'conv_417', 'conv_418', 'conv_419', 'conv_420', 'conv_421', 'conv_422', 'conv_423', 'conv_424', 'conv_425', 'conv_426', 'conv_427', 'conv_428', 'conv_429', 'conv_430', 'conv_431', 'conv_432', 'conv_433', 'conv_434', 'conv_435', 'conv_436', 'conv_437', 'conv_438', 'conv_439', 'conv_440', 'conv_441', 'conv_442', 'conv_443', 'conv_444', 'conv_445', 'conv_446', 'conv_447', 'conv_448', 'conv_449', 'conv_450', 'conv_451', 'conv_452', 'conv_453', 'conv_454', 'conv_455', 'conv_456', 'conv_457', 'conv_458', 'conv_459', 'conv_460', 'conv_461', 'conv_462', 'conv_463', 'conv_464', 'conv_465', 'conv_466', 'conv_467', 'conv_468', 'conv_469', 'conv_470', 'conv_471', 'conv_472', 'conv_473', 'conv_474', 'conv_475', 'conv_476', 'conv_477', 'conv_478', 'conv_479', 'conv_480', 'conv_481', 'conv_482', 'conv_483', 'conv_484', 'conv_485', 'conv_486', 'conv_487', 'conv_488', 'conv_489', 'conv_490', 'conv_491', 'conv_492', 'conv_493', 'conv_494', 'conv_495', 'conv_496', 'conv_497', 'conv_498', 'conv_499', 'conv_500', 'conv_501', 'conv_502', 'conv_503', 'conv_504', 'conv_505', 'conv_506', 'conv_507', 'conv_508', 'conv_509', 'conv_510', 'conv_511', 'conv_512', 'conv_513', 'conv_514', 'conv_515', 'conv_516', 'conv_517', 'conv_518', 'conv_519', 'conv_520', 'conv_521', 'conv_522', 'conv_523', 'conv_524', 'conv_525', 'conv_526', 'conv_527', 'conv_528', 'conv_529', 'conv_530', 'conv_531', 'conv_532', 'conv_533', 'conv_534', 'conv_535', 'conv_536', 'conv_537', 'conv_538', 'conv_539', 'conv_540', 'conv_541', 'conv_542', 'conv_543', 'conv_544', 'conv_545', 'conv_546', 'conv_547', 'conv_548', 'conv_549', 'conv_550', 'conv_551', 'conv_552', 'conv_553', 'conv_554', 'conv_555', 'conv_556', 'conv_557', 'conv_558', 'conv_559', 'conv_560', 'conv_561', 'conv_562', 'conv_563', 'conv_564', 'conv_565', 'conv_566', 'conv_567', 'conv_568', 'conv_569', 'conv_570', 'conv_571', 'conv_572', 'conv_573', 'conv_574', 'conv_575', 'conv_576', 'conv_577', 'conv_578', 'conv_579', 'conv_580', 'conv_581', 'conv_582', 'conv_583', 'conv_584', 'conv_585', 'conv_586', 'conv_587', 'conv_588', 'conv_589', 'conv_590', 'conv_591', 'conv_592', 'conv_593', 'conv_594', 'conv_595', 'conv_596', 'conv_597', 'conv_598', 'conv_599', 'conv_600', 'conv_601', 'conv_602', 'conv_603', 'conv_604', 'conv_605', 'conv_606', 'conv_607', 'conv_608', 'conv_609', 'conv_610', 'conv_611', 'conv_612', 'conv_613', 'conv_614', 'conv_615', 'conv_616', 'conv_617', 'conv_618', 'conv_619', 'conv_620', 'conv_621', 'conv_622', 'conv_623', 'conv_624', 'conv_625', 'conv_626', 'conv_627', 'conv_628', 'conv_629', 'conv_630', 'conv_631', 'conv_632', 'conv_633', 'conv_634', 'conv_635', 'conv_636', 'conv_637', 'conv_638', 'conv_639', 'conv_640', 'conv_641', 'conv_642', 'conv_643', 'conv_644', 'conv_645', 'conv_646', 'conv_647', 'conv_648', 'conv_649', 'conv_650', 'conv_651', 'conv_652', 'conv_653', 'conv_654', 'conv_655', 'conv_656', 'conv_657', 'conv_658', 'conv_659', 'conv_660', 'conv_661', 'conv_662', 'conv_663', 'conv_664', 'conv_665', 'conv_666', 'conv_667', 'conv_668', 'conv_669', 'conv_670', 'conv_671', 'conv_672', 'conv_673', 'conv_674', 'conv_675', 'conv_676', 'conv_677', 'conv_678', 'conv_679', 'conv_680', 'conv_681', 'conv_682', 'conv_683', 'conv_684', 'conv_685', 'conv_686', 'conv_687', 'conv_688', 'conv_689', 'conv_690', 'conv_691', 'conv_692', 'conv_693', 'conv_694', 'conv_695', 'conv_696', 'conv_697', 'conv_698', 'conv_699', 'conv_700', 'conv_701', 'conv_702', 'conv_703', 'conv_704', 'conv_705', 'conv_706', 'conv_707', 'conv_708', 'conv_709', 'conv_710', 'conv_711', 'conv_712', 'conv_713', 'conv_714', 'conv_715', 'conv_716', 'conv_717', 'conv_718', 'conv_719', 'conv_720', 'conv_721', 'conv_722', 'conv_723', 'conv_724', 'conv_725', 'conv_726', 'conv_727', 'conv_728', 'conv_729', 'conv_730', 'conv_731', 'conv_732', 'conv_733', 'conv_734', 'conv_735', 'conv_736', 'conv_737', 'conv_738', 'conv_739', 'conv_740', 'conv_741', 'conv_742', 'conv_743', 'conv_744', 'conv_745', 'conv_746', 'conv_747', 'conv_748', 'conv_749', 'conv_750', 'conv_751', 'conv_752', 'conv_753', 'conv_754', 'conv_755', 'conv_756', 'conv_757', 'conv_758', 'conv_759', 'conv_760', 'conv_761', 'conv_762', 'conv_763', 'conv_764', 'conv_765', 'conv_766', 'conv_767', 'conv_768', 'conv_769', 'conv_770', 'conv_771', 'conv_772', 'conv_773', 'conv_774', 'conv_775', 'conv_776', 'conv_777', 'conv_778', 'conv_779', 'conv_780', 'conv_781', 'conv_782', 'conv_783', 'conv_784', 'conv_785', 'conv_786', 'conv_787', 'conv_788', 'conv_789', 'conv_790', 'conv_791', 'conv_792', 'conv_793', 'conv_794', 'conv_795', 'conv_796', 'conv_797', 'conv_798', 'conv_799', 'conv_800', 'conv_801', 'conv_802', 'conv_803', 'conv_804', 'conv_805', 'conv_806', 'conv_807', 'conv_808', 'conv_809', 'conv_810', 'conv_811', 'conv_812', 'conv_813', 'conv_814', 'conv_815', 'conv_816', 'conv_817', 'conv_818', 'conv_819', 'conv_820', 'conv_821', 'conv_822', 'conv_823', 'conv_824', 'conv_825', 'conv_826', 'conv_827', 'conv_828', 'conv_829', 'conv_830', 'conv_831', 'conv_832', 'conv_833', 'conv_834', 'conv_835', 'conv_836', 'conv_837', 'conv_838', 'conv_839', 'conv_840', 'conv_841', 'conv_842', 'conv_843', 'conv_844', 'conv_845', 'conv_846', 'conv_847', 'conv_848', 'conv_849', 'conv_850', 'conv_851', 'conv_852', 'conv_853', 'conv_854', 'conv_855', 'conv_856', 'conv_857', 'conv_858', 'conv_859', 'conv_860', 'conv_861', 'conv_862', 'conv_863', 'conv_864', 'conv_865', 'conv_866', 'conv_867', 'conv_868', 'conv_869', 'conv_870', 'conv_871', 'conv_872', 'conv_873', 'conv_874', 'conv_875', 'conv_876', 'conv_877', 'conv_878', 'conv_879', 'conv_880', 'conv_881', 'conv_882', 'conv_883', 'conv_884', 'conv_885', 'conv_886', 'conv_887', 'conv_888', 'conv_889', 'conv_890', 'conv_891', 'conv_892', 'conv_893', 'conv_894', 'conv_895', 'conv_896', 'conv_897', 'conv_898', 'conv_899', 'conv_900', 'conv_901', 'conv_902', 'conv_903', 'conv_904', 'conv_905', 'conv_906', 'conv_907', 'conv_908', 'conv_909', 'conv_910', 'conv_911', 'conv_912', 'conv_913', 'conv_914', 'conv_915', 'conv_916', 'conv_917', 'conv_918', 'conv_919', 'conv_920', 'conv_921', 'conv_922', 'conv_923', 'conv_924', 'conv_925', 'conv_926', 'conv_927', 'conv_928', 'conv_929', 'conv_930', 'conv_931', 'conv_932', 'conv_933', 'conv_934', 'conv_935', 'conv_936', 'conv_937', 'conv_938', 'conv_939', 'conv_940', 'conv_941', 'conv_942', 'conv_943', 'conv_944', 'conv_945', 'conv_946', 'conv_947', 'conv_948', 'conv_949', 'conv_950', 'conv_951', 'conv_952', 'conv_953', 'conv_954', 'conv_955', 'conv_956', 'conv_957', 'conv_958', 'conv_959', 'conv_960', 'conv_961', 'conv_962', 'conv_963', 'conv_964', 'conv_965', 'conv_966', 'conv_967', 'conv_968', 'conv_969', 'conv_970', 'conv_971', 'conv_972', 'conv_973', 'conv_974', 'conv_975', 'conv_976', 'conv_977', 'conv_978', 'conv_979', 'conv_980', 'conv_981', 'conv_982', 'conv_983', 'conv_984', 'conv_985', 'conv_986', 'conv_987', 'conv_988', 'conv_989', 'conv_990', 'conv_991', 'conv_992', 'conv_993', 'conv_994', 'conv_995', 'conv_996', 'conv_997', 'conv_998', 'conv_999', 'conv_1000', 'conv_1001', 'conv_1002', 'conv_1003', 'conv_1004', 'conv_1005', 'conv_1006', 'conv_1007', 'conv_1008', 'conv_1009', 'conv_1010', 'conv_1011', 'conv_1012', 'conv_1013', 'conv_1014', 'conv_1015', 'conv_1016', 'conv_1017', 'conv_1018', 'conv_1019', 'conv_1020', 'conv_1021', 'conv_1022', 'conv_1023', 'conv_1024', 'conv_1025', 'conv_1026', 'conv_1027', 'conv_1028', 'conv_1029', 'conv_1030', 'conv_1031', 'conv_1032', 'conv_1033', 'conv_1034', 'conv_1035', 'conv_1036', 'conv_1037', 'conv_1038', 'conv_1039', 'conv_1040', 'conv_1041', 'conv_1042', 'conv_1043', 'conv_1044', 'conv_1045', 'conv_1046', 'conv_1047', 'conv_1048', 'conv_1049', 'conv_1050', 'conv_1051', 'conv_1052', 'conv_1053', 'conv_1054', 'conv_1055', 'conv_1056', 'conv_1057', 'conv_1058', 'conv_1059', 'conv_1060', 'conv_1061', 'conv_1062', 'conv_1063', 'conv_1064', 'conv_1065', 'conv_1066', 'conv_1067', 'conv_1068', 'conv_1069', 'conv_1070', 'conv_1071', 'conv_1072', 'conv_1073', 'conv_1074', 'conv_1075', 'conv_1076', 'conv_1077', 'conv_1078', 'conv_1079', 'conv_1080', 'conv_1081', 'conv_1082', 'conv_1083', 'conv_1084', 'conv_1085', 'conv_1086', 'conv_1087', 'conv_1088', 'conv_1089', 'conv_1090', 'conv_1091', 'conv_1092', 'conv_1093', 'conv_1094', 'conv_1095', 'conv_1096', 'conv_1097', 'conv_1098', 'conv_1099', 'conv_1100', 'conv_1101', 'conv_1102', 'conv_1103', 'conv_1104', 'conv_1105', 'conv_1106', 'conv_1107', 'conv_1108', 'conv_1109', 'conv_1110', 'conv_1111', 'conv_1112', 'conv_1113', 'conv_1114', 'conv_1115', 'conv_1116', 'conv_1117', 'conv_1118', 'conv_1119', 'conv_1120', 'conv_1121', 'conv_1122', 'conv_1123', 'conv_1124', 'conv_1125', 'conv_1126', 'conv_1127', 'conv_1128', 'conv_1129', 'conv_1130', 'conv_1131', 'conv_1132', 'conv_1133', 'conv_1134', 'conv_1135', 'conv_1136', 'conv_1137', 'conv_1138', 'conv_1139', 'conv_1140', 'conv_1141', 'conv_1142', 'conv_1143', 'conv_1144', 'conv_1145', 'conv_1146', 'conv_1147', 'conv_1148', 'conv_1149', 'conv_1150', 'conv_1151', 'conv_1152', 'conv_1153', 'conv_1154', 'conv_1155', 'conv_1156', 'conv_1157', 'conv_1158', 'conv_1159', 'conv_1160', 'conv_1161', 'conv_1162', 'conv_1163', 'conv_1164', 'conv_1165', 'conv_1166', 'conv_1167', 'conv_1168', 'conv_1169', 'conv_1170', 'conv_1171', 'conv_1172', 'conv_1173', 'conv_1174', 'conv_1175', 'conv_1176', 'conv_1177', 'conv_1178', 'conv_1179', 'conv_1180', 'conv_1181', 'conv_1182', 'conv_1183', 'conv_1184', 'conv_1185', 'conv_1186', 'conv_1187', 'conv_1188', 'conv_1189', 'conv_1190', 'conv_1191', 'conv_1192', 'conv_1193', 'conv_1194', 'conv_1195', 'conv_1196', 'conv_1197', 'conv_1198', 'conv_1199', 'conv_1200', 'conv_1201', 'conv_1202', 'conv_1203', 'conv_1204', 'conv_1205', 'conv_1206', 'conv_1207', 'conv_1208', 'conv_1209', 'conv_1210', 'conv_1211', 'conv_1212', 'conv_1213', 'conv_1214', 'conv_1215', 'conv_1216', 'conv_1217', 'conv_1218', 'conv_1219', 'conv_1220', 'conv_1221', 'conv_1222', 'conv_1223', 'conv_1224', 'conv_1225', 'conv_1226', 'conv_1227', 'conv_1228', 'conv_1229', 'conv_1230', 'conv_1231', 'conv_1232', 'conv_1233', 'conv_1234', 'conv_1235', 'conv_1236', 'conv_1237', 'conv_1238', 'conv_1239', 'conv_1240', 'conv_1241', 'conv_1242', 'conv_1243', 'conv_1244', 'conv_1245', 'conv_1246', 'conv_1247', 'conv_1248', 'conv_1249', 'conv_1250', 'conv_1251', 'conv_1252', 'conv_1253', 'conv_1254', 'conv_1255', 'conv_1256', 'conv_1257', 'conv_1258', 'conv_1259', 'conv_1260', 'conv_1261', 'conv_1262', 'conv_1263', 'conv_1264', 'conv_1265', 'conv_1266', 'conv_1267', 'conv_1268', 'conv_1269', 'conv_1270', 'conv_1271', 'conv_1272', 'conv_1273', 'conv_1274', 'conv_1275', 'conv_1276', 'conv_1277', 'conv_1278', 'conv_1279', 'conv_1280', 'conv_1281', 'conv_1282', 'conv_1283', 'conv_1284', 'conv_1285', 'conv_1286', 'conv_1287', 'conv_1288', 'conv_1289', 'conv_1290', 'conv_1291', 'conv_1292', 'conv_1293', 'conv_1294', 'conv_1295', 'conv_1296', 'conv_1297', 'conv_1298', 'conv_1299', 'conv_1300', 'conv_1301', 'conv_1302', 'conv_1303', 'conv_1304', 'conv_1305', 'conv_1306', 'conv_1307', 'conv_1308', 'conv_1309', 'conv_1310', 'conv_1311', 'conv_1312', 'conv_1313', 'conv_1314', 'conv_1315', 'conv_1316', 'conv_1317', 'conv_1318', 'conv_1319', 'conv_1320', 'conv_1321', 'conv_1322', 'conv_1323', 'conv_1324', 'conv_1325', 'conv_1326', 'conv_1327', 'conv_1328', 'conv_1329', 'conv_1330', 'conv_1331', 'conv_1332', 'conv_1333', 'conv_1334', 'conv_1335', 'conv_1336', 'conv_1337', 'conv_1338', 'conv_1339', 'conv_1340', 'conv_1341', 'conv_1342', 'conv_1343', 'conv_1344', 'conv_1345', 'conv_1346', 'conv_1347', 'conv_1348', 'conv_1349', 'conv_1350', 'conv_1351', 'conv_1352', 'conv_1353', 'conv_1354', 'conv_1355', 'conv_1356', 'conv_1357', 'conv_1358', 'conv_1359', 'conv_1360', 'conv_1361', 'conv_1362', 'conv_1363', 'conv_1364', 'conv_1365', 'conv_1366', 'conv_1367', 'conv_1368', 'conv_1369', 'conv_1370', 'conv_1371', 'conv_1372', 'conv_1373', 'conv_1374', 'conv_1375', 'conv_1376', 'conv_1377', 'conv_1378', 'conv_1379', 'conv_1380', 'conv_1381', 'conv_1382', 'conv_1383', 'conv_1384', 'conv_1385', 'conv_1386', 'conv_1387', 'conv_1388', 'conv_1389', 'conv_1390', 'conv_1391', 'conv_1392', 'conv_1393', 'conv_1394', 'conv_1395', 'conv_1396', 'conv_1397', 'conv_1398', 'conv_1399', 'conv_1400', 'conv_1401', 'conv_1402', 'conv_1403', 'conv_1404', 'conv_1405', 'conv_1406', 'conv_1407', 'conv_1408', 'conv_1409', 'conv_1410', 'conv_1411', 'conv_1412', 'conv_1413', 'conv_1414', 'conv_1415', 'conv_1416', 'conv_1417', 'conv_1418', 'conv_1419', 'conv_1420', 'conv_1421', 'conv_1422', 'conv_1423', 'conv_1424', 'conv_1425', 'conv_1426', 'conv_1427', 'conv_1428', 'conv_1429', 'conv_1430', 'conv_1431', 'conv_1432', 'conv_1433', 'conv_1434', 'conv_1435', 'conv_1436', 'conv_1437', 'conv_1438', 'conv_1439', 'conv_1440', 'conv_1441', 'conv_1442', 'conv_1443', 'conv_1444', 'conv_1445', 'conv_1446', 'conv_1447', 'conv_1448', 'conv_1449', 'conv_1450', 'conv_1451', 'conv_1452', 'conv_1453', 'conv_1454', 'conv_1455', 'conv_1456', 'conv_1457', 'conv_1458', 'conv_1459', 'conv_1460', 'conv_1461', 'conv_1462', 'conv_1463', 'conv_1464', 'conv_1465', 'conv_1466', 'conv_1467', 'conv_1468', 'conv_1469', 'conv_1470', 'conv_1471', 'conv_1472', 'conv_1473', 'conv_1474', 'conv_1475', 'conv_1476', 'conv_1477', 'conv_1478', 'conv_1479', 'conv_1480', 'conv_1481', 'conv_1482', 'conv_1483', 'conv_1484', 'conv_1485', 'conv_1486', 'conv_1487', 'conv_1488', 'conv_1489', 'conv_1490', 'conv_1491', 'conv_1492', 'conv_1493', 'conv_1494', 'conv_1495', 'conv_1496', 'conv_1497', 'conv_1498', 'conv_1499', 'conv_1500', 'conv_1501', 'conv_1502', 'conv_1503', 'conv_1504', 'conv_1505', 'conv_1506', 'conv_1507', 'conv_1508', 'conv_1509', 'conv_1510', 'conv_1511', 'conv_1512', 'conv_1513', 'conv_1514', 'conv_1515', 'conv_1516', 'conv_1517', 'conv_1518', 'conv_1519', 'conv_1520', 'conv_1521', 'conv_1522', 'conv_1523', 'conv_1524', 'conv_1525', 'conv_1526', 'conv_1527', 'conv_1528', 'conv_1529', 'conv_1530', 'conv_1531', 'conv_1532', 'conv_1533', 'conv_1534', 'conv_1535', 'conv_1536', 'conv_1537', 'conv_1538', 'conv_1539', 'conv_1540', 'conv_1541', 'conv_1542', 'conv_1543', 'conv_1544', 'conv_1545', 'conv_1546', 'conv_1547', 'conv_1548', 'conv_1549', 'conv_1550', 'conv_1551', 'conv_1552', 'conv_1553', 'conv_1554', 'conv_1555', 'conv_1556', 'conv_1557', 'conv_1558', 'conv_1559', '

However, the statistical reliability at the class level was limited by the number of available samples (approximately ten test images per letter). Therefore, future work includes expanding the dataset to 100–150 images per class, incorporating additional metrics such as recall and F1-score, validating the system in real educational scenarios with end users, and evaluating its performance under more variable lighting conditions to ensure robustness in uncontrolled contexts. The use of five images per class was intended to represent a minimal scenario for observing overfitting and classification instability under limited data conditions, whereas the configuration with 15 images per class provided a mid-level setting that increased sample variability and improved prediction stability. Finally, using 50 images per class provided a more representative dataset, enabling the system to achieve competitive accuracy levels consistent with those reported in the literature for CNN-based sign recognition [13]–[15]. The corresponding test results are summarized in Table I, whereas the performance curve is shown in Fig. 8.

A. Tests With Five Images per Class

In an initial exploratory phase, the model was trained using five images per class of the finger alphabet. The results showed high instability in predictions, especially for visually similar letters. Overall accuracy was low, and the system exhibited limited generalization to slight variations in posture, lighting, and background.

B. Tests With 15 Images per Class

In the second iteration, the dataset was increased to 15 images per class. This expansion resulted in substantial improvements in model learning, with a significant increase in overall accuracy and reduced sensitivity to external conditions. However, some misclassifications persisted among classes with similar morphologies.

C. Tests With 50 Images per Class

In the third phase, the model was trained using 50 images per class. Under this configuration, the system achieved its best overall performance. High recognition accuracy, a decreased error rate, and a more stable response were observed under controlled lighting conditions (300 lumens/250 lux). Furthermore, the average processing speed remained at 125 fps.

Performance varied slightly depending on the letter. The most difficult classes to identify were those with similar handforms, such as “M” and “N,” or “U” and “V,” which exhibited higher error rates. In contrast, letters with distinctive features such as “L,” “T,” or “Y” achieved accuracies above 95%.

Under the configuration with 50 images per class, the model achieved accuracies above 90% for 21 of the 26 evaluated letters and maintained a minimum accuracy of 85% for

TABLE I
PERFORMANCE COMPARISON OF THE THREE
MAIN TESTS

	Images by class	Accuracy (%)	Loss	Response time (FPS)	Observations
1	5	63.4%	1.2	5.4	Low learning with high errors
2	15	79.6%	0.8	3.2	Better learning and control
3	50	97%	0.2	1.8	High model accuracy and stability

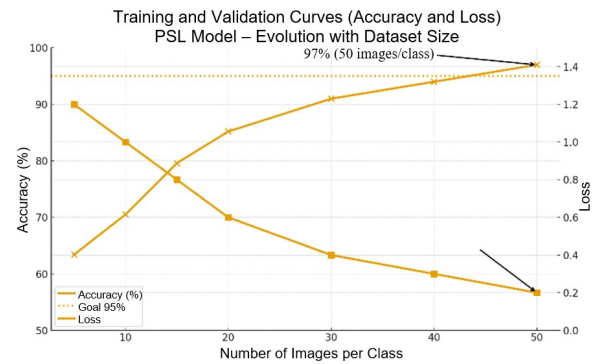

Fig. 8. Training and validation curve of the PSL model.

the remaining classes, demonstrating strong generalization capability under optimal environmental conditions.

In addition to overall accuracy, other relevant metrics were calculated to further assess the system’s overall performance:

- WER: 15% with 50 images/class
- Average accuracy of 97%
- Average processing speed: 125 fps

These metrics confirm that the system is functional in real time and suitable for educational environments provided that controlled conditions—such as a uniform background, stable lighting, and minimal visual interference—are maintained.

IV. DISCUSSION

The results obtained from the experimental tests enable a comparison of the system’s performance with respect to the proposed objectives and existing technological solutions. The initial objective of this prototype was to achieve an accuracy between 95% and 99% in recognizing letters of the PSL finger alphabet while maintaining a real-time

response time of less than 2 s, thereby allowing the system to be considered viable for inclusive educational settings.

Despite the promising results, this project presents several limitations. In particular, the dataset size was limited to 50 images per class, which restricts the statistical reliability of per-class performance metrics. All experiments were conducted under controlled conditions of lighting and background conditions, which limits the system's robustness in real-world environments. In addition, the prototype focused primarily on static letters of the PSL alphabet and a limited set of dynamic gestures, without addressing the recognition of complete words or sentences. Finally, validation with end users in real classroom settings has not yet been conducted, which is necessary to assess usability and scalability.

A. Comparison With Accessibility Mobile Applications

National platforms such as [2] and [3] provide basic accessibility features through manual selection or voice-to-text conversion. However, both are limited to static, predefined vocabularies without visual gesture recognition. In contrast, the proposed prototype achieved an average accuracy of 97% in real-time operation at 125 fps, providing automatic visual-to-speech translation of live gestures and overcoming the static nature and limited scalability of these applications.

B. Comparison With Systems Based on Physical Sensors

Wearable-device-based systems, such as those reported in [5] and [6], achieve accuracy ranges under standard conditions and up to 96% when specialized sensors are used. Although technically effective, these solutions are intrusive, costly, and require frequent calibration, which makes them impractical for routine classroom use. In contrast, the proposed model relies solely on a standard camera and achieves a real-time correct prediction rate of 91.3% using 50 images per class, thus eliminating the discomfort and cost associated with gloves and sensors.

C. Comparison With International CNN Recognition Models

International proposals such as [4], [13], and [15] reported accuracies in the range of 93–98% using large ASL or ISL datasets under controlled conditions. Similarly, advanced hybrid models such as those presented in [11], [14], [16], and [17] demonstrate robust performance; however, they typically depend on large-scale datasets, cloud-based infrastructure, and application contexts different from Peru. By contrast, the proposed prototype achieved an accuracy of 97% and a WER of 15% using a locally constructed Peruvian dataset, thereby ensuring cultural relevance while operating on low-cost hardware.

D. Comparison With Patented Solutions

Patented devices such as those described in [19]–[21] focus on glove-based or camera-assisted translation of foreign sign languages and report accuracies above 90%.

However, these solutions rely on specialized hardware and do not address the specific requirements of the Peruvian context. This prototype differs by integrating CNN and SVM models trained on a PSL dataset, providing a scalable, camera-only solution tailored to local conditions.

V. CONCLUSIONS

In summary, the prototype meets the established objectives by exceeding 95% accuracy, achieving an average accuracy of 97%, and operating in real time at a processing speed of 125 frames per second. This performance is competitive with international models and offers a practical advantage over intrusive solutions such as sensor-enhanced gloves. Furthermore, the objective of developing a non-invasive and low-cost solution was achieved, with an approximate 30% savings compared to sensor-based systems. Its contextualization within the Peruvian environment was guaranteed by using the Bilingual Dictionary of PSL as a reference.

Its accessible and educational nature reinforces its potential as an inclusive tool. However, it is acknowledged that the results are based on tests under controlled conditions and with a dataset limited to 50 images per class. Therefore, future work will focus on validating the system in real-life classroom settings, using a larger sample size and incorporating additional evaluation metrics such as recall and F1 score.

REFERENCES

- [1] Ombudsman's Office, "Situation of inclusive education in Peru," Ombudsman's Office, Lima, Peru, 2022.
- [2] Pontificia Universidad Católica del Perú, "Diccionario LSP al Español [Virtual Bilingual Dictionary of Peruvian Sign Language]," 2022. [Online]. Available: <https://diccionariolsp.pucp.edu.pe/search-by-text>
- [3] *Yapaykuy*. (2023). App Store. Lima, Peru. [Mobile app]. Available: <https://apps.apple.com/pe/app/yapaykuy/id6478118708>
- [4] K. Abbas, R. Kumar, and P. Jain, "Sign language recognition using CNN," *IEEE Trans. Neural Netw. Learn. Syst.*, vol. 32, no. 5, pp. 1941–1953, May 2021.
- [5] J. DelPreto, J. Hughes, M. D'Aria, M. de Fazio, and D. Rus, "A wearable smart glove and its application of pose and gesture detection to sign language classification," *IEEE Robot. Autom. Lett.*, vol. 7, no. 4, pp. 10589–10596, 2022, doi: 10.1109/LRA.2022.3191232.
- [6] A. Ji, Y. Wang, X. Miao, T. Fan, B. Ru, L. Liu, R. Nie, and S. Qiu, "Dataglove for sign language recognition of people with hearing and speech impairment via wearable inertial sensors," *Sensors*, vol. 23, no. 15, Art. no. 6693, 2023, doi: 10.3390/s23156693

- [7] A. Radzi, S. Salim, M. H. Abd Wahab, M. M. Abdul Jamil, and T. C. Phing, "Development of a wearable sensor glove for real-time sign language translation." *Ann. Emerg. Technol. Comput.*, vol. 7, no. 5, pp. 25-38. doi: 10.33166/AETiC.2023.05.003
- [8] World Health Organization, *World Report on Hearing*. Geneva, Switzerland: WHO, 2021. [Online]. Available: <https://www.who.int/publications/i/item/world-report-on-hearing>
- [9] H. Knoors, and M. Marschark, "Language planning for the 21st century: Revisiting bilingual language policy for deaf children," *J. Deaf Stud. Deaf Educ.*, vol. 17, no. 3, pp. 291-305, 2012, doi: 10.1093/deafed/ens018.
- [10] C. Tannenbaum-Baruchi, B. Ahad Ha'am, and R. Harari, "Accessibility and support in higher education: A case study of deaf and hard of hearing students' perceptions," *High. Educ.*, 2025, doi: 10.1007/s10734-025-01586-x.
- [11] H. Wang, et al., "Enhanced open biomass burning detection: The BrantNet approach using UAV aerial imagery and deep learning for environmental protection and health preservation," *Ecol. Indic.*, vol. 154, Art. no. 110788, 2023, doi: 10.1016/j.ecolind.2023.110788.
- [12] L. Findlater et al., "Design preferences and barriers for deaf and hard of hearing users of mobile technology," in *Proc. ASSETS 2019*, Pittsburgh, PA, USA, Oct. 28-30 2019.
- [13] A. Gangal, A. Kuppahally, and M. Ravindran, *Sign Language Recognition with Convolutional Neural Networks*, Stanford CS231n Project Report, 2024. [Online]. Available: <https://cs231n.stanford.edu/2024/papers/sign-language-recognition-with-convolutional-neural-networks.pdf>
- [14] A. Kasapbaşı, A. E. A. Elbushra, O. Al-Hardanee, and A. Yilmaz, "DeepASLR: A CNN-based human-computer interface for American Sign Language recognition for hearing-impaired individuals," *Comput. Methods Programs Biomed. Update*, vol. 2, p. 100048, Jan. 2022, doi: 10.1016/j.cmpbup.2021.100048.
- [15] S. Subburaj, S. Murugavalli, and B. Muthusenthil, "Sign language video to text conversion via optimised LSTM with improved motion estimation," *J. Exp. Theor. Artif. Intell.*, vol. 37, no. 1, pp. 163-182, 2024, doi: 10.1080/0952813X.2024.2380991.
- [16] Y. Wang, H. Jiang, Y. Sun, and L. Xu, "A static sign language recognition method enhanced with self-attention mechanisms," *Sensors*, vol. 24, no. 21, p. 6921, 2024, doi: 10.3390/s24216921.
- [17] A. Elhagry and R. G. Elrayes, "Egyptian Sign Language recognition using CNN and LSTM," *arXiv*, Jul. 28, 2021. [Online]. Available: <https://arxiv.org/abs/2107.13647>
- [18] S. M. S. Swetha, M. S. Muneshwara, V. Venkatesh, S. M. S. Kudremane, R. S. Nair, and V. H. Vismitha, "Developing a translation model to bridge ASL and Indian regional languages using neural networks," in *Proc. 2025 Int. Conf. Comput. Sustain. Intell. Future (COMP-SIF)*, Bangalore, India, Mar. 21-22, 2025, pp. 1-6.
- [19] Indian Patent Office, *A sign language translator glove*, Patent application IN201841026260 A, Jul. 20, 2018. [Online]. Available: https://patentscope.wipo.int/search/es/detail.jsf?docId=IN224134191&_cid=P20-MFKLFW-88048-1
- [20] Indian Patent Office, *Sign language translator for deaf and speech impaired*, Patent application IN202321041213 A, 2023. [Online]. Available: https://patentscope.wipo.int/search/es/detail.jsf?docId=IN414860224&_cid=P20-MFKLWX-89227-1
- [21] Korean Intellectual Property Office, *Sign language translator and method thereof, particularly for translating the video of a finger language into a voice or text*, Patent KR1020100026701 A, 2010. [Online]. Available: https://patentscope.wipo.int/search/es/detail.jsf?docId=KR5842487&_cid=P20-MFKLHM-90082-1
- [22] J. A. Czechowicz et al., "Hearing impairment and poverty: The epidemiology of ear disease in Peruvian schoolchildren," *Otolaryngol. Head Neck Surg.*, vol. 142, no. 2, pp. 272-277, 2010. doi: 10.1016/j.otohns.2009.10.040
- [23] B. Alsharif, A. S. Altaher, A. Altaher, M. Liyas, and E. Alalwany, "Deep learning technology to recognize American Sign Language alphabet," *Sensors*, vol. 23, no. 19, p. 7970, 2023. doi: 10.3390/s23197970
- [24] D. Kothadiya, C. Bhatt, K. Sapariya, K. Patel, A.-B. Gil-González, and J. M. Corchado, "Deepsign: Sign language detection and recognition using deep learning," *Electronics*, vol. 11, no. 11, p. 1780, 2022. doi: 10.3390/electronics11111780
- [25] K. Assaleh and M. Al-Rousan, "Recognition of Arabic sign language alphabet using polynomial classifiers," *EURASIP Journal on Advances in Signal Processing*, vol. 2005, Art. no. 507614, 2005, doi: 10.1155/ASP.2005.2136

BIOGRAPHICAL NOTES

SONIA JOANNA LEÓN JIMÉNEZ

Sonia Joanna León Jiménez holds a Bachelor's degree in Industrial Engineering from Universidad de Lima, Peru. She is currently an intern in Project Management at Siemens Energy, where she contributes to the management and coordination of projects in the energy sector, with a focus on process planning and optimization. She won first place in the 8th edition of the Regional Energy Efficiency Program organized by Siemens for a proposal recognized for its potential to advance energy efficiency and sustainability, representing Universidad de Lima in an international competition. Her academic projects include "Optimization of Resources and Parameters in Mine Wastewater Treatment through Reverse Osmosis and pH Control," which focused on improving industrial processes with an emphasis on sustainability and efficiency. Her research interests include automation, project management, and industrial design, with a particular focus on resource optimization, technological innovation, and digital transformation in industrial applications.

CLAUDIA C. LEON-CHAVARRI

Claudia C. Leon-Chavarri holds a Master of Engineering in Civil and Environmental Engineering from the Massachusetts Institute of Technology (MIT), United States, and a Bachelor of Engineering in Industrial Engineering from Universidad de Lima, Peru. She currently teaches in the Industrial Engineering Program at Universidad de Lima, is registered as a RENACYT researcher at Level VII, and has served as Vice President of the MIT Club Peru since 2026. She is General Manager of Ingenio Consultoría & Emprendimiento SAC and previously taught full-time at Universidad Peruana de Ciencias Aplicadas (UPC). She is a Senior Fellow of the IEEE and a member of the ACM. Her publications include "A Production Management Method to Reduce Non-Fulfillment of Orders Based on Lean Tools and Change Management: Case of a Peruvian Apparel Company" and "Process Optimization through the Implementation of SLP, Kanban, Poka-Yoke and TPM to Improve Efficiency in a Metalworking SME," both published in the International Journal of Engineering Trends and Technology. Her areas of interest include sustainable design, sustainable manufacturing, textile sustainability, water treatment, and photocatalysis.

RAFAEL CHÁVEZ UGAZ

Rafael Chávez Ugaz holds a Master's degree in Strategic Business Administration from Centrum Católica, Peru; a Master of Business Administration in General and Strategic Management from Maastricht School of Management, the Netherlands; a degree in Management from the Netherlands; and a Bachelor of Engineering in Industrial Engineering from Universidad de Lima, Peru. He currently teaches in

the Industrial Engineering Program at Universidad de Lima, where he is also a researcher and a member of the Faculty of Engineering Council. He previously participated as an associate researcher in technological innovation projects funded by Fondecyt. His publications include "Implementation of Lean Manufacturing and SLP in an SME in the Jewelry Sector: Case Study," published in the International Congress on Innovation and Trends in Engineering; "Ergonomic Risk Management Model Using RULA, NIOSH and OCRA Techniques in a Metalworking SME," published in the Proceedings of the LACCEI International Multi-Conference for Engineering, Education and Technology; and "Textile Characteristics of Huacaya Alpaca Fiber, According to Agroecological Zones, Sex and Age in the Puno Region (Peru)," published in the Peruvian Journal of Veterinary Research. His areas of interest include production operations for goods and services, supply chain management, and last-mile logistics.

LUCIA BRITNEY SUNI CHAVEZ

Lucia Britney Suni Chavez holds a Bachelor's degree in Industrial Engineering from Universidad de Lima, Peru. She is currently an intern in the Services Department at TKE Elevator, where she has gained pre-professional experience in the industrial services sector and contributes to operational coordination and process management through data analysis and performance monitoring. Her research interests include operations and service management, maintenance and asset management, operations planning and control, performance measurement, and continuous process improvement, with an emphasis on optimization and operational efficiency in industrial settings.

FABRICIO HUMBERTO PAREDES LARROCA

Fabricio Humberto Paredes Larroca holds a PhD in Systems Engineering from Universidad Nacional de Ingeniería, a Master's degree in Automation and Instrumentation from the same institution, and a degree in Industrial Engineering from Universidad de Lima. He has also completed further studies at the Massachusetts Institute of Technology (MIT), earning certifications in Industry 4.0, Internet of Things, Machine Learning, and Smart Manufacturing. He currently serves as a Full Professor and Researcher at Universidad de Lima. His academic career includes teaching experience since 2002 and positions such as Academic Coordinator, Head of the CIM Laboratory, and Member of the School Council. He has participated in scientific projects related to non-potable water treatment, the development of solar photocatalytic reactor prototypes, intelligent process control using fuzzy logic, and technological innovation aimed at improving the quality of life of people with disabilities. He holds more than ten patents registered in Peru, related to automation devices, renewable energy, applied robotics, and solutions for the agricultural sector. He has a strong publication record indexed in Scopus and Web of

Science, with research published in high-impact journals on water treatment, applied artificial intelligence, and environmental sustainability. His research focuses on automation, control systems, applied artificial intelligence, smart manufacturing, and industrial engineering.

EZILDA CABRERA GIL GRADOS

Ezilda Cabrera Gil Grados holds a Master's degree in Business Administration from Universidad ESAN, Peru, and a degree in Industrial Engineering from Universidad de Lima, Peru. She currently works as a professor in the Industrial Engineering Program at Universidad de Lima.

She has published the book *Linear Programming Models: A Guide to Their Formulation and Solution* (Fondo Editorial de la Universidad de Lima, 2017) and several articles in academic conference proceedings, including "Improvement Proposal to Achieve Shrinkage Reduction in the Home Dispatch Process in a Retail Company," "The Origins and Evolution of Social Commerce: Enhancing E-Commerce Platforms with Social Features," "Home Office Physical and Psychosocial Ergonomic Effects on the Job Satisfaction of Service Sector Employees in Peru," and "Study of Carbon Monoxide Levels in the Most Traveled Streets of Metropolitan Lima," among others. Her main professional area of interest is operations research.

Document Process Automation in an International Logistics Company Using OCR, RPA, and Text Analytics

Nayeli M. Soto Leiva¹ , Yair R. Cubas Pecho² , José A. Taquía Gutiérrez³ , Juan C. Quiroz Flores⁴ 

¹20194631@aloe.ulima.edu.pe, ²20180528@aloe.ulima.edu.pe, ³jtaquia@ulima.edu.pe, ⁴jcquiroz@ulima.edu.pe

¹²³⁴Carrera de Ingeniería Industrial, Universidad de Lima, Perú

Received: July 22, 2025 / Accepted: October 6, 2025 / Published: 5 June, 2026

doi: <https://doi.org/10.26439/ciii2025.8661>

ABSTRACT—This study aims to optimize the document settlement process in a Peruvian foreign trade logistics company through the implementation of intelligent automation technologies, including robotic process automation (RPA), optical character recognition (OCR), and text analytics. This process, initially characterized by intensive manual tasks, typing errors, and excessive processing times, limited operational performance and generated bottlenecks in logistics operations. Among the main findings, a 49% reduction in average processing time for work orders was observed. During functional validation, the average number of work orders processed per shift was measured. An increase from 4.03 to 6.00 work orders per shift was reported, representing an improvement of 1.97 work orders per shift following the implementation of automation. It is concluded that document automation represents an effective and scalable strategy for improving logistics performance in document processing. As a future goal, automation is planned to be expanded to all administrative areas with repetitive and standardized operational processes.

Index Terms—Data extraction, document processing, optical character recognition (OCR), robotic process automation (RPA), text analytics.

I. INTRODUCTION

The logistics sector in Peru has undergone rapid transformation in recent years, driven by digitalization, the growth of e-commerce, and the need to adapt to international standards of operational efficiency. The sector projects an annual growth rate of 7.4%, positioning itself as one of the key economic activities for national competitiveness [1]. However, much of this industry still faces structural challenges, such as the lack of automation in document-related

processes, which limits traceability, productivity, and the ability to respond to increased demand.

While leading companies such as DHL and FedEx already operate automated systems that integrate artificial intelligence and document analysis, many Peruvian organizations still rely on manual procedures, achieving on-time delivery (OTD) rates of approximately 85%, below the international benchmark of 95% [1]. This scenario highlights a technological gap that must be addressed through innovative solutions that combine speed, accuracy, and scalability.

In environments where document processes are still largely manual, the lack of automation represents a barrier to achieving effective logistics performance. The absence of intelligent tools to streamline and structure management limits operational responsiveness and hinders business growth in an increasingly demanding market. Faced with this problem, this study aims to optimize the document settlement process through the implementation of intelligent automation technologies.

In response to this problem, this study proposes an intelligent document automation model that integrates robotic process automation (RPA), optical character recognition (OCR), and text analytics. These technologies have proven effective in reducing processing times and error rates in complex document environments [2], [3], [4], [5].

The primary objective of this research is to optimize document flow within logistics processes through an adaptable technological solution validated in a real-world environment. To this end, a system was designed to automatically label files, extract key information, and consolidate data into a structured format. The solution not only aims to improve key performance indicators (KPIs) but also to relieve staff from repetitive tasks, allowing them to focus on higher-value-added activities. From a technological perspective, the proposed solution promotes the adoption of

modern technologies aligned with the sector's digital transformation. From an economic perspective, it contributes to cost reduction by minimizing errors and penalties, thereby improving profitability and operational sustainability.

This was supported by scientific articles, which are classified by typology as shown below:

A. RPA Applied to Document Flows

RPA has proven to be an effective tool for digitizing and structuring repetitive operational workflows. Its use allows reducing manual workload, minimizing human errors, and improving document traceability [2], [5]. In administrative contexts, the combination of RPA with recognition technologies allows automating data extraction from scanned documents and validating them in a structured manner [6]. This type of technology has been widely applied in the banking, government, and logistics sectors, enhancing document processing efficiency while reducing processing times [7].

Furthermore, RPA enables the incorporation of automated validation rules, thereby improving data quality at the source. This approach is particularly useful for repetitive tasks such as data entry, information consolidation, and document verification [6], [8].

B. OCR for Data Extraction

OCR has evolved significantly using machine learning models and deep neural networks. This technology has been optimized to extract information from invoices, contracts, and scanned documents, even when presented in irregular formats or with poor visual quality [1], [4], [9].

Among the main improvements are automatic text slant correction, visual noise removal, and adaptation to diverse fonts and structures [3], [9]. In addition, current models can interpret handwritten, multilingual, and partially damaged content, expanding their applicability in highly demanding environments such as document logistics [10]–[12].

C. RPA and OCR Integration: Operational Synergies

Integrating RPA with OCR enables end-to-end automation of document workflows, from file ingestion to final data consolidation. This approach significantly reduces processing times and human intervention-related errors, particularly in administrative sectors with high document volumes [6], [7], [13].

The combined use of these tools facilitates structured information extraction, automated quality control, and report generation. Recent literature also highlights that their successful implementation depends on adequate management change and the involvement of operational staff in the redesign of automated workflows [14].

This hybrid model is also related to the concept of hyperautomation, understood as the combination of robotic

automation with artificial intelligence and machine learning to optimize complex and dynamic processes [15].

D. Text Analytics and Intelligent Document Processing

Intelligent document processing, based on text analytics and machine learning algorithms, enables the automation of tasks beyond simple digitization, by interpreting semantic content, logical structure and contextual information of unstructured documents [12].

This approach enables the automated detection of key entities, semantic relationships among fields, and content-based task prioritization. The use of these tools improves document organization, optimizes traceability, and reduces human intervention in routine review and classification activities [12], [16].

Furthermore, these models have proven to be particularly useful in scenarios involving a high volume of heterogeneous files. Their application has been validated in contexts such as financial auditing, healthcare, and digital logistics, allowing information extraction even from non-standardized structures or in multilingual documents [12], [16], [17].

II. METHODOLOGY

A. Bases of the Proposed Model

The proposed solution is based on the integration of RPA, OCR and text analytics. These tools were selected following a systematic review of the scientific literature, which demonstrated their effectiveness in environments with high document volumes. Recent studies confirm that RPA–OCR integration reduces document processing times [7], while semantic processing enhances accuracy in the automatic classification of operational files [8], [12]. In these contexts, the automated extraction of data from structured and semi-structured documents has significantly reduced processing times [18]. Likewise, the use of OCR enhanced with image processing techniques to convert scanned documents into machine-readable data, even under low visual quality conditions, is highlighted [4]. In addition, text analytics-based approaches enable the automatic classification of unstructured files, contributing to improved document organization and operational traceability. [8], [19].

B. Proposed Model

The model proposed in this research addresses the limitations identified in a Peruvian foreign trade logistics company, where a high dependence on manual document processing was observed. This reliance results in delays in customs declarations and directly affects the timely clearance of goods from the seaport. As a solution, a functional intelligent document automation architecture was implemented based on the sequential integration of three technologies: RPA, OCR, and text analytics.

The process begins with the retrieval of files stored in a folder labeled “Work Order” within the company’s enterprise resource planning (ERP) system. These documents, primarily in PDF format and lacking a defined structure, are automatically labeled using a Python-based script hosted in a collaborative environment (Google Colab). The script applies text analytics rules to identify document types (e.g., invoices, bills of lading (B/L), policies), thereby addressing the lack of uniform file labeling. [3]. This initial phase improves traceability and facilitates subsequent document validation by the operator in accordance with the corresponding work order.

The labeled documents are subsequently processed by a UiPath-based robot. This robot automatically reads the files using OCR and extracts key fields, such as the taxpayer identification number (RUC in Spanish), dates, amounts, and Incoterms, which are consolidated into a structured template. This step addresses the need to automate data consolidation and mitigate human errors in manual entry [1], [20].

To handle scanned documents or those with low visual quality, the model relies on machine learning-enhanced OCR engines capable of interpreting text under non-ideal conditions [5], [23].

Finally, the extracted data are organized into an Excel spreadsheet using standardized nomenclature, making them ready for validation and subsequent entry into the customs system. This modular and externalized approach enables integration without affecting existing systems, favoring scalability to other document areas.

C. Model Components

- 1) *Diagnosis of the Current Process:* The study began with the identification of operational deficiencies in the document settlement process of a logistics company located in Lima, Peru. To this end, qualitative and quantitative analysis tools were applied to characterize the initial situation. In the first stage, semi-structured interviews were conducted with staff from the various involved areas, enabling an understanding of the actual process flow and the identification of its main constraints.

Subsequently, the current process was mapped, and a Pareto chart was applied to identify the most significant issue within the document clearance area. Based on this finding, an Ishikawa diagram was created to structure the probable causes of the identified problem. These elements were organized into a problem tree to graphically represent the relationship between observed effects and their root causes.

To validate and quantify the problem, a representative sample of work orders processed under real operating conditions was defined. The initial sample comprised 120 work orders, from which 92

were selected through simple random sampling and used to measure key process indicators.

Finally, the data obtained were analyzed using discrete-event simulation in Arena software. This analysis enabled an assessment of the process’s behavior prior to the intervention, based on three key indicators: average system time, utilization of the human resource responsible for the process (the “settler”), and the number of orders completed per cycle.

- 2) *Design of the Technological Intervention:* Based on the findings of the diagnostic phase, a functional architecture integrating three key technologies—RPA, OCR, and text analytics—was designed. This technological proposal was structured into four sequential stages comprising the automated document processing workflow:
 - 2a) *Preliminary reading and automatic labeling:* A Python-based script was implemented and executed in a collaborative environment (Google Colab), applying a basic OCR engine in conjunction with text analytics rules. This tool enabled the identification of PDF file content associated with each work order and the automatic assignment of labels according to document type (e.g., invoice, policy, manifest).
 - 2b) *Structured data extraction:* An RPA model developed in UiPath was responsible for directly processing the labeled files. The RPA applied OCR with advanced parameters and identified key fields using predefined semantic rules—such as invoice number, supplier tax identification number, issue date, and Incoterms—as illustrated in Fig. 1.
 - 2c) *Data validation and organization:* Once the extraction was complete, the RPA automatically organized the data into an Excel spreadsheet, enabling rapid access to the document information. This structuring aims to significantly reduce the time required for manual input into customs document declaration platforms, while also minimizing human error in data entry.
- 3) *Model Validation:* The effectiveness of the proposed model was validated through a comparative simulation between the baseline scenario (without improvement) and the intervened scenario. The simulation results were analyzed using the Output Analyzer platform. The results aim to demonstrate the value of the proposed approach by analyzing the number of work orders processed per shift, the average time a work order remains in the system, and the utilization of operational resources, specifically the document settlement operator.

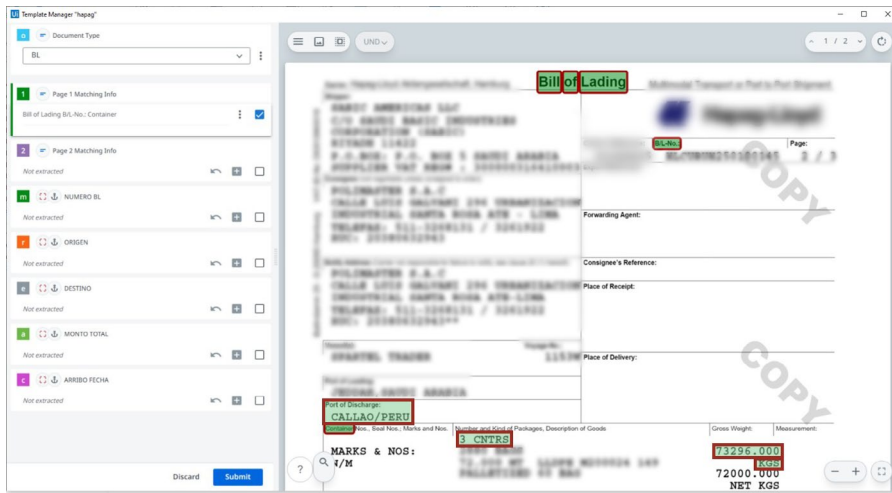

Fig. 1. Data extraction from a bill of lading (B/L) document.

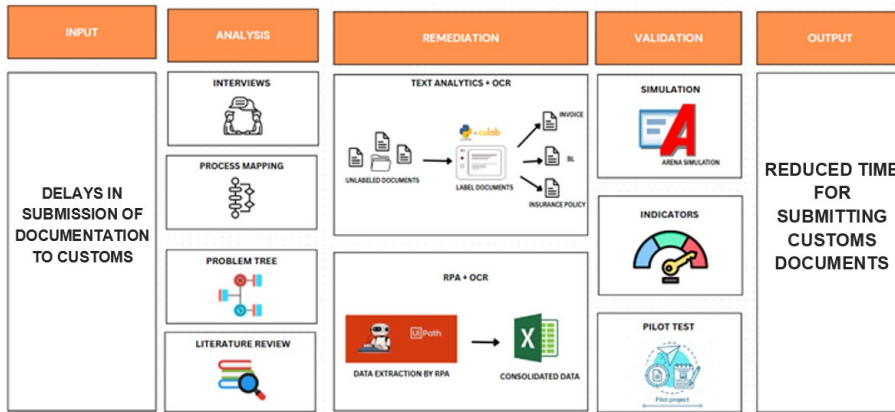

Fig. 2. Model of RPA and OCR implementation.

Fig. 2 illustrates the proposed conceptual model, highlighting the expected outcomes of implementing the defined processes and tools.

III. RESULTS

The proposed model was validated through simulations in Arena software, as shown in Fig. 5, and a pilot test in a company in the foreign trade logistics sector. For the simulation in Arena, 479 replications were run to ensure statistical reliability with a 94% confidence level. The results showed substantial improvements across three key indicators: the number of work orders processed per 8-h shift, the average system time per work order, and the utilization rate of the primary operational resource (liquidator), as summarized in Table I.

In the baseline scenario, the system processed an average of 5.45 records per 8-h shift, with a 94% confidence

interval of [5.39, 5.52]. After implementing the RPA-OCR-text analytics solution, this indicator increased to 7.39 records per shift, with a 94% confidence interval of [7.35, 7.42], representing a 35% productivity improvement without additional staffing. The average time a document remained in the system decreased from 123 min in the baseline scenario to 62.7 min after automation, representing a 49% reduction. This improvement directly impacts operational agility and the timely availability of information for subsequent processes. Regarding resource utilization, the liquidator's utilization slightly decreased from 99.7% to 89.2%. Although this reduction is moderate, it is significant, as a higher number of documents were processed within the same shift while maintaining—and slightly reducing—the staff workload. These results indicate that the automated system enables a more fluid and efficient workflow by optimizing the liquidator's time and improving their productivity, as shown in Fig. 3.

Statistical comparison using the paired t-test confirmed that the changes achieved with the proposed solution were not random. For all performance indicators, the confidence intervals for the mean differences did not include zero, confirming that the improvements are statistically significant and attributable to the implemented redesign, as shown in Fig. 4.

Additionally, a pilot test was initiated in May 2025, during which partial operation of the document automation tool was implemented. In this context, the monthly evolution of the average processing time per order is presented in Fig. 6. During the first eight months analyzed, processing times remained high, ranging from 105 to 130 min, reflecting the operational burden of the manual process and remaining within the parameters estimated by the Output Analyzer. However, starting in May—coinciding with the technological intervention—a progressive improvement became evident. In June and July, despite minor fluctuations, processing times remained below 71 min, consolidating a sustained reduction compared to the previous period.

This behavior suggests that the automated system enabled a more streamlined workflow, allowing staff to validate data more efficiently without the need to perform repetitive manual tasks. Although the values still reflect a learning curve for operators, the trend shows that the technological implementation effectively contributed to reducing bottlenecks, improving productivity, and reducing human errors in the customs documentation process.

IV. DISCUSSION

The behavior observed in the validation phase suggests that the automated system enabled a smoother workflow, allowing staff to validate data more efficiently while reducing manual, repetitive tasks. Although the results still reflect a learning curve for operators, the trend indicates that the technological implementation effectively contributed to reducing bottlenecks, improving productivity, while reducing human errors in the customs documentation process.

The results obtained from the simulation and pilot test confirm that intelligent automation applied to the document clearance process is a viable and effective strategy for addressing the main operational issues arising from manual information processing.

The integration of RPA, OCR, and text analytics enabled the redesign of the document flow by eliminating repetitive tasks, reducing human errors, and significantly shortening execution times. These findings are consistent with prior studies that highlight the benefits of robotic automation in improving efficiency, traceability, and data accuracy in administrative processes [2], [5], [6], [7].

In addition, the use of advanced OCR optimized through machine learning was critical for interpreting scanned

TABLE I
COMPARISON OF INDICATORS BEFORE AND AFTER IMPROVEMENT

Indicators	As is	To be
Number of orders processed	5.45	7.39
Average time (min) of the work order in the system	123	62.7
% utilization of the liquidator	99.7%	89.2%

Prepared by authors.

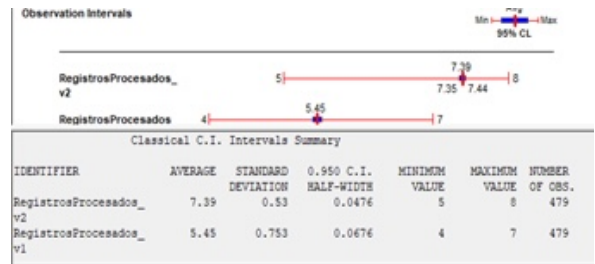

Fig. 3. Work order comparison.

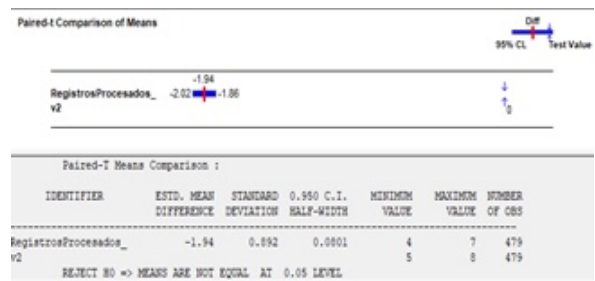

Fig. 4. Paired t-test validation. Authors' elaboration.

documents with poor visual quality. This capability has been documented in recent studies that emphasize the robustness of current OCR engines when handling non-edible, degraded, or multi-font documents [4], [9], [11].

The inclusion of text analytics techniques addressed one of the primary limitations identified during the initial diagnosis: the lack of standardized file nomenclature. These techniques enabled automatic document classification, facilitated file retrieval, and improved overall traceability [12], [16], [17].

From a digital transformation perspective, this model represents a step toward hyperautomation, understood as the integration of RPA with artificial intelligence and semantic processing to optimize complex processes [15].

Likewise, the quantitative results showed a 35% increase in the number of orders processed per shift and

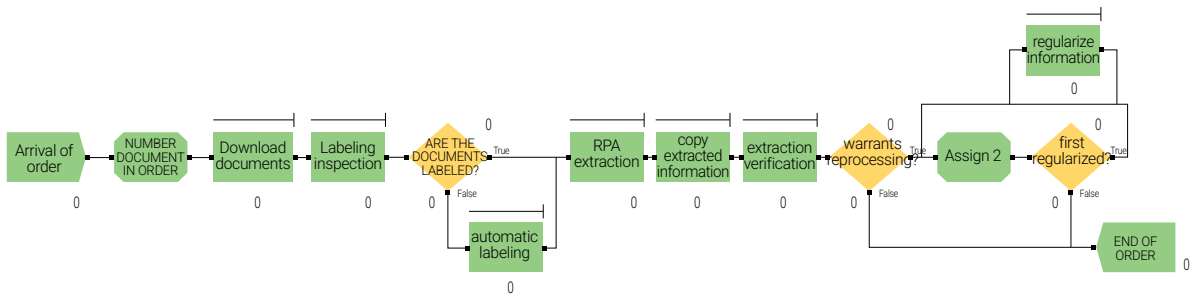

Fig. 5. Flowchart in Arena of the improvement proposal. Authors’ elaboration.

a 49% reduction in the average processing time per order. These indicators demonstrate not only improved operational efficiency but also more effective utilization of human resources, as staff workload was reduced without compromising productivity—and, in fact, with a measurable improvement.

Although an operational learning curve was identified, the progressive trend observed after the intervention—as evidenced by the pilot test—validates the effectiveness of the proposed technological architecture and supports its scalability to other areas of the organization.

Furthermore, this model can be adapted to other administrative sectors with similar characteristics —such as standardized and repetitive workflows, high document volumes, and traceability requirements—thereby reinforcing its applicability as a comprehensive solution within institutional modernization processes.

V. CONCLUSIONS

This research demonstrates that intelligent automation, applied to the document settlement process in logistics operations, is an effective approach for mitigating the primary operational issues associated with manual information processing. Using a model comprised of RPA, OCR, and text analytics, the work order processing flow was redesigned, eliminating repetitive tasks, reducing human errors, while significantly shortening execution times.

The model was validated through both simulation and real-world pilot testing, achieving a 35% increase in the number of orders processed per cycle and a 49% reduction in average order processing time. These results demonstrate that the integration of automation technologies not only enhances human resource productivity but also improves the traceability and accuracy of document records, which is critical in customs-related operations.

Furthermore, the use of text analytics tools helped overcome initial limitations such as the lack of standardized file nomenclature, thereby facilitating document access and classification prior to data extraction. RPA, in turn, proved

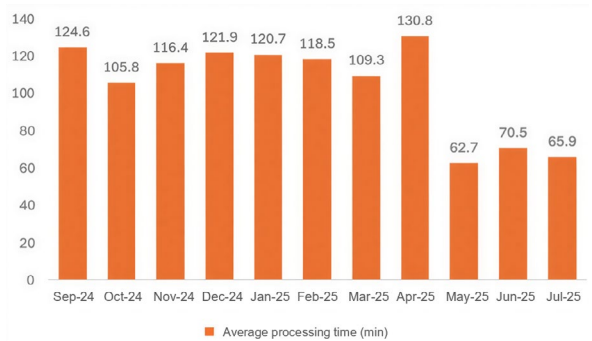

Fig. 6. Average processing times for a work order.

effective in structuring, validating, and consolidating critical information, even from non-editable or low-quality documents, through its integration with advanced OCR.

Finally, the results observed in the months following the technological intervention indicate a sustained improvement trend, despite staff remaining in a learning-curve phase. This reinforces the viability of the proposed model and supports its scalability to other internal processes. Consequently, the progressive adoption of intelligent automation-based solutions represents a fundamental step toward modernizing logistics services in a highly demanding and competitive environment.

REFERENCES

- [1] Ministerio de Economía y Finanzas (MEF), “Marco Macroeconómico Multianual 2024-2027” [“Multiannual Macroeconomic Framework 2024-2027”], Gob.pe, 2024. [Online]. Available: <https://www.gob.pe/institucion/mef/informes-publicaciones/5603986-marco-macroeconomico-multianual-2024-2027>
- [2] C. A. Bermúdez Irreño, “RPA - automatización robótica de procesos: Una revisión de la literatura”

- ["RPA - robotic process automation: A review of the literature"], *Rev. Ing. Mat. Cienc. Inf.*, vol. 8, no. 15, pp. 111-122, 2021, doi: <https://doi.org/10.21017/rimci.2021.v8.n15.a97>
- [3] T. Saout, F. Lardeux, and F. Saubion, "An overview of data extraction from invoices," *IEEE Access*, vol. 12, pp. 19872-19886, Jan. 2024, doi: <https://doi.org/10.1109/ACCESS.2024.3360528>
- [4] A. Haleem, M. Javaid, R. P. Singh, S. Rab, and R. Suman, "Hyperautomation for the enhancement of automation in industries," *Sens. Int.*, vol. 2, 100124, Aug. 2021, doi: <https://doi.org/10.1016/j.sintl.2021.100124>
- [5] Instituto Nacional de Estadística e Informática, "PBI de las actividades económicas por años [GDP of economic activities by year]," Instituto Nacional de Estadística e Informática, 2023. [Online]. Available: <https://www.inei.gob.pe/estadisticas/indice-tematico/pbi-de-las-actividades-economicas-por-anos-9096>
- [6] A. Waqar et al., "Assessment of barriers to robotic process automation (RPA) implementation in safety management of tall buildings," *Buildings*, vol. 13, no. 7, p. 1663, Jun. 2023, doi: <https://doi.org/10.3390/buildings13071663>
- [7] K. A. Saavedra Mera, B. M. Quiñonez Cabeza, A. H. Quiñonez Klinger, and V. J. Sarango Romero, "La digitalización de la cadena de suministro: Un impulso innovador para la eficiencia logística en Ecuador [Supply chain digitalization: An innovative boost for logistics efficiency in Ecuador]," *Código Cient. Rev. Investig.*, vol. 4, no. 2, pp. 210-224, Dec. 2023, doi: <https://doi.org/10.55813/gaea/ccri/v4/n2/238>
- [8] A. A. Manjunath et al., "Automated invoice data extraction using image processing," *IAES Int. J. Artif. Intell.*, vol. 12, no. 2, pp. 514-521, Jun. 2023, doi: <https://doi.org/10.11591/ijai.v12.i2.pp514-521>
- [9] S. A. Francis and M. Sangeetha, "A comparison study on optical character recognition models in mathematical equations and in any language," *Results Control Optim.*, vol. 18, no. 1, Art. no. 100532, Mar. 2025, doi: <https://doi.org/10.1016/j.rico.2025.100532>
- [10] A. Deekshith, "Advances in natural language processing: A survey of techniques," *Int. J. Innov. Eng. Res. Technol.*, vol. 8, no. 3, pp. 74-83, Oct. 2024, doi: <https://doi.org/10.26662/ijiert.v8i3.pp74-83>
- [11] J. Villena Toro, A. Wiberg, and M. Tarkian, "Optical character recognition on engineering drawings to achieve automation in production quality control," *Front. Manuf. Technol.*, vol. 3, 1154132, Mar. 2023, doi: <https://doi.org/10.3389/fmtec.2023.1154132>
- [12] J. Kokina, S. Blanchette, T. H. Davenport, and D. Pachamanova, "Challenges and opportunities for artificial intelligence in auditing: Evidence from the field," *Int. J. Account. Inf. Syst.*, vol. 56, 100734, Dec. 2025, doi: <https://doi.org/10.1016/j.accinf.2025.100734>
- [13] D. C. Villarreal Meza, M. G. Cevallos Vizuete, D. C. Arias Portalanza, and K. A. Moya Palacios, "Optimización de los procesos de logística, su mejora y satisfacción al cliente [Optimization of logistics processes, its improvement and customer satisfaction]," *Conciencia Digital*, vol. 5, no. 1.3, pp. 216-233, Mar. 2022, doi: <https://doi.org/10.33262/concienciadigital.v5i1.3.2137>
- [14] L. Isaza and K. Cepa, "Automation and augmentation: A process study of how robotization shapes tasks of operational employees," *Eur. Manag. J.*, Dec. 2024, doi: <https://doi.org/10.1016/j.emj.2024.11.010>
- [15] J. Ribeiro, R. Lima, T. Eckhardt, and S. Paiva, "Robotic process automation and artificial intelligence in industry 4.0: A literature review," *Procedia Comput. Sci.*, vol. 181, pp. 51-58, Jan. 2021, doi: <https://doi.org/10.1016/j.procs.2021.01.104>
- [16] K. Soeny, G. Pandey, U. Gupta, A. Trivedi, M. Gupta, and G. Agarwal, "Attended robotic process automation of prescriptions' digitization," *Smart Health*, vol. 20, 100189, Apr. 2021, doi: <https://doi.org/10.1016/j.smhl.2021.100189>
- [17] C. Flechsig, F. Anslinger, and R. Lasch, "Robotic process automation in purchasing and supply management: A multiple case study on potentials, barriers, and implementation," *J. Purch. Supply Manag.*, vol. 28, no. 1, 100718, Jan. 2022, doi: <https://doi.org/10.1016/j.pursup.2021.100718>
- [18] S. İ. Omurca, E. Ekinci, S. Sevim, E. B. Edinç, S. Eken, and A. Sayar, "A document image classification system fusing deep and machine learning models," *Appl. Intell.*, vol. 53, no. 12, pp. 15295-15310, Nov. 2022, doi: <https://doi.org/10.1007/s10489-022-04306-5>
- [19] N. Gal-Nadasan, V. Stoicu-Tivadar, E. Gal-Nadasan, and A. R. Dinu, "Robotic process automation based data extraction from handwritten medical forms," *Stud. Health Technol. Inform.*, vol. 309, pp. 68-72, Oct. 2023, doi: <https://doi.org/10.3233/SHTI230741>
- [20] S.-H. Kim, "Development of evaluation criteria for robotic process automation (RPA) solution selection," *Electronics*, vol. 12, no. 4, p. 986, Feb. 2023, doi: <https://doi.org/10.3390/electronics12040986>
- [21] M. Borkowski, W. Fdhila, M. Nardelli, S. Rinderle-Ma, and S. Schulte, "Event-based failure prediction in distributed business processes," *Inf. Syst.*, vol. 81, pp. 220-235, Mar. 2019, doi: <https://doi.org/10.1016/j.is.2017.12.005>

- [22] A. S. Villar and N. Khan, "Robotic process automation in banking industry: A case study on Deutsche Bank," *J. Bank. Financ. Technol.*, vol. 5, no. 1, pp. 71–86, May 2021, doi: <https://doi.org/10.1007/s42786-021-00030-9>
- [23] Mordor Intelligence, "Peru freight and logistics market size & share analysis: Growth trends and forecast (2025–2030)," Mordor Intelligence, 2025. [Online]. Available: <https://www.mordorintelligence.com/industry-reports/peru-freight-and-logistics-market>

BIOGRAPHICAL NOTES

NAYELI MARINALE SOTO LEIVA

Nayeli Marinalé Soto Leiva holds a Bachelor's degree in Industrial Engineering from Universidad de Lima, Peru, and ranked in the top third of her class. Since 2022, she has created and managed her own business dedicated to event decoration, applying tools related to e-commerce, marketing, process improvement, customer-flow analysis, and input management, while integrating technical knowledge with a customer-experience approach. She currently works at Dirección Regional de Agricultura de Cajamarca, where she has performed duties in logistics and later in the administrative area of an investment project, while continuing to manage her business. She has been a member of the Innovation Circle at Universidad de Lima. Her main academic and professional areas of interest include process improvement, quality management, customer experience, service management, and logistics.

YAIR RAUL CUBAS PECHO

Yair Raul Cubas Pecho holds a Bachelor's degree in Industrial Engineering from Universidad de Lima. He currently works as a professional intern in Human Resources, where he participates in the digital transformation of administrative processes through the design and implementation of

automation solutions for administrative control. He has developed internal web-based query systems that allow employees to access personalized employment information, contributing to operational efficiency and the modernization of talent management. His main areas of interest include finance, capital markets, process automation, and data analytics applied to business management.

JOSÉ ANTONIO TAQUÍA GUTIÉRREZ

José Antonio Taquía Gutiérrez holds a PhD in Business Management from Universidad Nacional Mayor de San Marcos and a Master's degree in Industrial Engineering from Universidad de Lima. In the private sector, he has participated in several technology project implementations applied to operations in supply chain processes and decision-support systems for leading retail companies. He has also developed projects for the Instituto de Investigación Científica of Universidad de Lima. His main research interests are process improvement, predictive analytics, and Industry 4.0.

JUAN CARLOS QUIROZ-FLORES

Juan Carlos Quiroz-Flores holds a PhD in Business Management from Universidad Nacional Mayor de San Marcos, a Master's degree in Business Administration from ESAN Graduate School of Business, and a degree in Industrial Engineering from Universidad de Lima, with certifications in Lean Six Sigma and Lean Manufacturing. He is a Research Professor and Coordinator of Degrees and Diplomas at Universidad de Lima, with more than 140 articles indexed in Scopus and Web of Science. He is a full member of Sigma Xi, in recognition of his scientific output, and a member of Beta Gamma Sigma for academic excellence in his graduate studies. He specializes in lean supply chain, process improvement, and productivity, and has more than 20 years of experience in operations management in manufacturing, services, and retail companies.

Multiplicity of Artificial Intelligence Models for Bias Control

Juan R. Jaramillo 

Associate Professor with the Department of Innovation and Entrepreneurship,
Long Island University, New York, USA

juan.jaramillo@liu.edu

Received: August 14, 2025 / Published: October 25, 2025 / Published: 5 June, 2026

doi: <https://doi.org/10.26439/ciii2025.8662>

I. INTRODUCTION

The so-called Rashomon effect is inspired by Akira Kurosawa's film *Rashomon*. In the film, four witnesses present different and contradictory accounts of the same crime. A similar situation is observed when multiple artificial intelligence (AI) and machine learning (ML) models generate solutions that achieve the same level of performance yet differ from one another when applied to the same dataset. More precisely, the so-called *Rashomon effect* [1] refers to the existence of multiple models with similar performance. These models may generate different and even contradictory predictions at the individual level [2]. In other words, two models with the same predictive capability may produce different predictions for certain observations. For example, consider a situation in which the objective is to predict loan defaults for 100 bank clients. A bank analyst developed two different models with an accuracy of 99%. In this case, one model misclassifies Pedro, whereas the second model misclassifies María.

In many cases, these differences could be associated with biases that are difficult to identify, leading to models that may favor or negatively affect certain groups. The Rashomon effect, also known as multiplicity, provides an opportunity to explore alternative models in order to identify those with acceptable predictability and greater

robustness. Understanding these biases allows the development of more socially fair and responsible AI systems.

The origins of multiplicity are inherent in the generation and training processes of AI and ML models. The following section briefly discusses these causes.

II. ORIGINS OF MULTIPLICITY

The main sources of multiplicity include the preselected feature set, the optimization function, the geometry of the loss function, random data partitioning, random parameters initialization, and the hyperparameter tuning.

A. Variable Selection

In the early stages of data analysis, highly correlated variables are often removed. Methods such as Lasso regression reduce parameter dimensionality and computational burden. Although the resulting models may exhibit similar accuracy, they differ and may produce conflicting predictions for similar datasets.

B. Optimization Function and Geometry

The loss function used in the training process influences the structure of the final model. For example, minimizing the sum of squared errors

and minimizing absolute errors would result in different models. Additionally, complex loss functions with multiple local optima may produce distinct models. Notably, gradient descent, which is commonly used for training, does not guarantee a global optimum. For complex models, obtaining a true global optimum may be computationally infeasible.

C. Data Partitioning

Splitting data into training, evaluation, and validation sets introduces variability. For example, an 85%/10%/5% split may produce models with greater similarity but increases the risk of overfitting compared with a 70%/20%/10% split. Random partitioning itself can produce models using similar performance metrics (e.g., R^2) but slightly different predictive behaviors.

D. Random Initialization

Many algorithms begin with random parameter initialization (e.g., regression coefficients or neural network weights). When the objective function contains multiple local optima or flat regions, parameter initial values influence the resulting best model. For example, neural networks may produce models with different parameters that yield similar performance on training data but could diverge on unseen data. Fig. 1 shows multiple models obtained with different ML techniques. For each technique 1,000 different 80/20 partitions were used. The chart illustrates the variability of R^2 values represented by box plots.

E. Hyperparameter Tuning

Hyperparameters such as learning rate, number of iterations, tree depth, and number of trees (in ensemble methods) can produce models with similar aggregate performance but differing at the individual prediction level.

III. METRICS TO MEASURE MULTIPLICITY

The first step in evaluating multiplicity is to identify the set of models with acceptable

predictive performance [3], [4]. This set is known as the Rashomon set (1):

$$R = \{m \in M \mid L(m) \geq L(m^*) + \epsilon\} \quad (1)$$

where $L(m)$ represents the loss function, m^* denotes the best-performing model, and (ϵ) is the maximum acceptable deviation from the best model.

Other metrics are defined as follows:

- **Rashomon ratio:** The percentage of models in the Rashomon set relative to the total number of models considered. In practice, the number of possible models is computationally intractable.
- **Capacity:** The histogram of final error values across models belonging to the Rashomon set.
- In the case of classification problems, some metrics include the following:
 - **Ambiguity:** The percentage of observations that receive conflicting predictions across models in the Rashomon set.
 - **Discrepancy:** The percentage of observations with different predictions between two specific models. Similarly, for regression problems two metrics are defined as follows:
 - Mean prediction error across models in the Rashomon set.
 - Standard deviation of prediction errors.

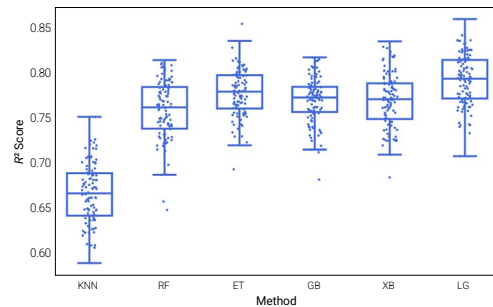

Fig. 1. R^2 results for 1,000 partitions (80%/20%).

IV. IMPLICATIONS

Multiplicity enables a deeper evaluation beyond selecting the model with minimal error. The Rashomon set allows comparison across models with similar predictive performance but potentially differing fairness characteristics.

For example, a résumé-screening model trained on historical hiring data may favor graduates from one university over another. Within the Rashomon set, alternative models with similar predictive power may reduce such disparities. Incorporating secondary fairness metrics can help identify models with lower bias while maintaining predictive performance.

V. CONCLUSION

In industry practice, selecting the single best-performing model often ignores the existence of equally predictive alternatives. Analysts frequently underestimate the variability introduced by data selection and algorithmic approximation.

Multiplicity allows identification of more robust models, sometimes with improved social impact and only marginal reductions in predictive accuracy. Therefore, generating Rashomon sets and incorporating secondary evaluation metrics are recommended to ensure robustness and positive societal impact.

REFERENCES

- [1] L. Breiman, "Statistical modeling: The two cultures," *Stat. Sci.*, vol. 16, no. 3, pp. 199–215, Aug. 2001, doi: 10.1214/ss/1009213726
- [2] C. Rudin *et al.*, "Amazing things come from having many good models," 2025, *arXiv:2407.04846*.
- [3] L. Semenova, C. Rudin, and R. Parr, "On the existence of simpler machine learning models," in *Proc. ACM Conf. Fairness, Accountability, and Transparency (FACT '22)*, Seoul, Republic of Korea, 2022, pp. 1827–1858, doi: 10.1145/3531146.3533232.
- [4] Fisher, C. Rudin, and F. Dominici, "All models are wrong, but many are useful: Learning a variable's importance by studying an entire class of prediction models simultaneously," *J. Mach. Learn. Res.*, vol. 20, no. 177, pp. 1–81, Jan. 2019. [Online]. Available: <https://jmlr.csail.mit.edu/papers/volume20/18-760/18-760.pdf>

BIOGRAPHICAL NOTES

JUAN JARAMILLO

Juan Jaramillo holds a PhD in Industrial Engineering from West Virginia University. He is currently an Associate Professor of Data Analytics at Long Island University. He also serves as President of the INFORMS Analytics Society and as an Advisory Board Member for Dhaxle. He has co-authored "The Innovation Sandbox: Why Organización Corona Partners with Academia to Solve the Data Challenges of Tomorrow" (*OR/MS Today*, 2026); "A Deep Learning Counting Model Applied to Quality Control" (*Journal of Modelling in Management*, 2023); "Alcohol, Illicit Drugs, and Suicide Mortality Trends Stratified by Age, Gender, and Race for 2006–2019" (*American Journal of Lifestyle Medicine*, 2023); and the textbook *Machine Learning for Business Analytics* (Routledge, 2022). His research interests include machine learning, deep learning, bias control in AI, supply chain analytics, and the application of data envelopment analysis to healthcare and economic performance.



UNIVERSIDAD
DE LIMA